



Fluids and Lubricants Specifications

All Commercial mtu Series Diesel Engines (including Marine),
DDC S60 Off Highway and Two-Stroke Cycle Engines
Excluding mtu Series 1000-1600, 1800

A001061/41E



Rolls-Royce Solutions refers to Rolls-Royce Solutions GmbH or an affiliated company pursuant to §15 AktG (German Stock Corporation Act) or a controlled company (joint venture), and Rolls-Royce Solutions Ruhstorf GmbH.

© Copyright Rolls-Royce Solutions

This publication is protected by copyright and may not be used in any way, whether in whole or in part, without the prior written consent of Rolls-Royce Solutions. This particularly applies to its reproduction, distribution, editing, translation, microfilming and storage and/or processing in electronic systems including databases and online services.

All information in this publication was the latest information available at the time of going to print. Rolls-Royce Solutions reserves the right to change, delete or supplement the information provided as and when required.

Table of Contents

1	Preface		5.5 Heating oil EL	100
1.1	General information	5	5.6 Supplementary fuel additives	101
2	Lubricants for Four-Cycle Engines		5.7 Unsuitable materials in the diesel fuel circuit	104
2.1	Engine oils	7	6 NOx Reducing Agent AUS 32 / AUS 40 for SCR Exhaust Gas Aftertreatment Systems	
2.2	Fluorescent dyestuffs for detecting leaks in the lube oil circuit	17	6.1 General information	105
2.3	Lubricating greases	18	7 Approved Engine Oils and Lubricating Greases	
3	Lubricants for Two-Cycle Engines		7.1 Engine Oils for Four-Cycle Engines	107
3.1	Engine oils	19	7.1.1 Series-based usability of engine oils of oil category 1	107
4	Coolants		7.1.2 Single-grade oils - Category 1, SAE grades 30 and 40 for diesel engines	109
4.1	General information	22	7.1.3 Multigrade oils - Category 1, SAE grades 15W-40 for diesel engines	110
4.2	Unsuitable materials in the coolant circuit	24	7.1.4 Series-based usability of engine oils of oil categories 2 and 2.1 (low SAPS oils)	111
4.3	Requirements imposed on freshwater	25	7.1.5 Single-grade oils - Category 2, SAE-grades 30 and 40 for diesel engines	114
4.4	Emulsifiable corrosion inhibitor oils	26	7.1.6 Multi-grade oils - Category 2, SAE grades 10W-30, 10W-40, 15W-40 and 20W-40 for diesel engines	117
4.5	Antifreeze	28	7.1.7 Multi-grade oils - Category 2.1 (Low SAPS oils), SAE grades 0W-30, 10W-30, 5W-40, 10W-40 and 15W-40 for diesel engines	127
4.6	Coolant without antifreeze	30	7.1.8 Series-based usability of engine oils of oil categories 3 and 3.1 (low SAPS oils)	131
4.7	Operational monitoring	31	7.1.9 Multi-grade oils - Category 3, SAE grades 5W-30, 5W-40, 10W-40 and 15W-40 for diesel engines	133
4.8	Limit values for coolants	35	7.1.10 Multi-grade oils - Category 3.1 (Low SAPS oils), SAE grades 5W-30, 10W-30 and 10W-40 for diesel engines	138
4.9	Storage capability of coolant concentrates	36	7.2 Engine Oils for Two-Cycle Engines	144
4.10	Color additives to detect leakage in the coolant circuit	37	7.2.1 Series-based usability for two-cycle engine oils	144
5	Liquid Fuels		7.2.2 Engine oils for two-stroke cycle engines	145
5.1	Diesel fuels - General information	38	7.3 Lubricating Greases	146
5.2	Series-dependent approval of fuel grades for mtu engines	45	7.3.1 Lubricating greases for general applications	146
5.2.1	Distillate fuels as per DIN EN590 and ASTM D975	45	8 Approved Coolants	
5.2.2	British Standard	51	8.1 Series- and application-based usability of coolant additives	147
5.2.3	Chinese distillate fuels according to GB 19147-2016, GB 252-2015 and GB 17411-2016	54	8.2 Emulsifiable corrosion-inhibiting oils	155
5.2.4	Heating oil	60	8.3 Coolants without antifreeze for cooling systems containing light metal	156
5.2.5	Marine distillate fuels according to ISO 8217:2018-10	65		
5.2.6	Aviation turbine fuel	73		
5.2.7	NATO diesel fuels	76		
5.2.8	Paraffinic diesel fuel according to DIN EN 15940	89		
5.2.9	Engine operation on diesel fuel with a biodiesel content of up to 30%	90		
5.3	Engine operation on pure biodiesel (B100) and vegetable oil	95		
5.4	Diesel fuels for engines with exhaust gas aftertreatment (EGAT)	98		

8.3.1	Coolant without antifreeze - Concentrates for cooling systems containing light metal	156	8.8.4	Antifreeze - Ready mixtures for two-stroke cycle engines	187
8.3.2	Coolant without antifreeze - Ready mixtures for cooling systems containing light metal	157	8.9	Coolant Additives with Limited Series Approval	190
8.4	Coolants without antifreeze for cooling systems free of light metal	158	8.9.1	Antifreeze - Concentrates and ready mixtures on ethylene-glycol basis for engines with and without light metal	190
8.4.1	Coolants without antifreeze - Concentrates for cooling systems free of light metal	158	8.9.2	Antifreeze - Ready mixtures based on propylene glycol for engine series free of light metal	191
8.4.2	Coolant without antifreeze - Ready mixtures for cooling systems free of light metal	160	9	Flushing and Cleaning Specifications for Engine Coolant Circuits	
8.5	Antifreezes for cooling systems containing light metal	161	9.1	General information	192
8.5.1	Antifreeze - Concentrates for cooling systems containing light metal	161	9.2	Fresh water requirements for cleaning solutions and flushing water	193
8.5.2	Antifreeze - Ready mixtures for cooling systems containing light metals	164	9.3	Approved cleaning agents	194
8.6	Antifreezes for cooling systems free of light metal	167	9.4	Engine coolant circuits - Flushing	195
8.6.1	Antifreeze - Concentrates for cooling systems free of light metal	167	9.5	Engine coolant circuits - Cleaning	196
8.6.2	Antifreeze - Ready mixtures for cooling systems free of light metals	171	9.6	Removal of heavy corrosion in coolant circuits using Decorrdaal 20-1	197
8.7	Coolant Additives for Series 60 Engines	174	9.7	Cleaning engine coolant circuit assemblies	198
8.7.1	Coolant without antifreeze - Concentrates for Series 60 engines	174	9.8	Coolant circuits contaminated with bacteria, fungi or yeast	199
8.7.2	Coolant without antifreeze - Ready mixtures for Series 60 engines	175	10	Cleaning the Product Externally	
8.7.3	Antifreeze - Concentrates for Series 60 engines	176	10.1	General information	200
8.7.4	Antifreeze - Ready mixtures for Series 60 engines	179	10.2	Approved cleaning agents	201
8.8	Coolant Additives for Two-Cycle Engines	182	11	Revision Overview	
8.8.1	Coolant without antifreeze - Concentrates for two-stroke cycle engines	182	11.1	Revision overview from version A001061/40 to A001061/41	202
8.8.2	Coolant without antifreeze - Ready mixtures for two-stroke cycle engines	183	12	Appendix A	
8.8.3	Antifreeze - Concentrates for two-stroke cycle engines	184	12.1	Index	208

1 Preface

1.1 General information

These Fluids and Lubricants Specifications contain general instructions for the proper and safe operation of your product from the manufacturer Rolls-Royce Solutions.

Used symbols and means of representation

The following instructions are highlighted in the text and must be observed:

Important

This field contains product information which is important or useful for the user. It refers to instructions, work and activities that have to be observed to prevent damage or destruction to the material.

Note:

A note provides special instructions that must be observed when performing a task.

Fluids and lubricants

The useful life, operational reliability and function of the drive units are largely dependent on the fluids and lubricants employed. The correct selection and treatment of these fluids and lubricants are therefore extremely important. This publication specifies which fluids and lubricants are to be used.

mtu ValueCare portfolio

Rolls-Royce Solutions offers approved oils and coolants tailored to meet engine requirements under the mtu ValueCare agreement.

Test standards for fluids and lubricants

Test standard	Designation
DIN	Federal German Standards Institute
EN	European Standards
ISO	International Standards Organization
ASTM	American Society for Testing and Materials
IP	Institute of Petroleum
DVGW	German Gas and Water Industry Association

Table 1:

Monitoring of fluids and lubricants

The maintenance of fluids and lubricants includes regular monitoring. Relevant information on how samples should be taken and handled can be found in the Customer Information "Taking and handling samples for laboratory analyses" (publication number A001080/..). The most recent version can be called up under:

<http://www.mtu-solutions.com>

If you have any questions, your contact person will be happy to help you.

Applicability of this publication

The Fluids and Lubricants Specifications will be amended or supplemented as necessary. Prior to use, ensure that the most recent version is available. The most recent version can be called up under:

<http://www.mtu-solutions.com>

If you have any questions, your contact person will be happy to help you.

Warranty

Use of the approved fluids and lubricants, either under the brand name or in accordance with the specifications given in this publication, constitutes part of the warranty conditions.

The supplier of the fluids and lubricants is responsible for the worldwide standard quality of the named products.

Important

Fluids and lubricants for drive units may be hazardous materials. Certain regulations must be obeyed when handling, storing and disposing of these substances.

These regulations are contained in the manufacturers' instructions, such as product-specific safety data sheets, statutory regulations and technical guidelines valid in the individual countries. Great differences can apply from country to country and a generally valid guide to applicable regulations for fluids and lubricants is therefore not possible within this publication.

Users of the products named in these specifications are therefore obliged to inform themselves of the locally valid regulations. Rolls-Royce Solutions accepts no liability whatsoever for improper or illegal use of the fluids and lubricants which it has approved.

Preservation

All information on preservation, represervation and depreservation including the approved preservatives is available in the Preservation and Represervation Specifications (publication number A001070/...). The most recent version can be called up under:

<http://www.mtu-solutions.com>

2 Lubricants for Four-Cycle Engines

2.1 Engine oils

Important

Dispose of used fluids and lubricants in accordance with local regulations.
Used oil must never be disposed of via the internal combustion engine!

Requirements for the approval of engine oils by Rolls-Royce Solutions

The requirements of Rolls-Royce Solutions for the approval of engine oils for diesel engines are contained in the delivery standards MTL 5044 and MTL 5051 for first-use oils and corrosion inhibitor oils. For two-stroke cycle engine oils, oil approval requirements are contained in the delivery standard MTL 5111. These standards can be ordered under these reference numbers.

Manufacturers of engine oils are notified in writing if their product is approved.

Approved diesel engine oils are divided into the following quality categories:

- Oil category 1: Standard quality / Single and multi-grade oils
- Oil category 2: Higher quality / Single and multi-grade oils
- Oil category 2.1: Multi-grade oils with a low ash-forming additive content (low SAPS oils)
- Oil category 3: Highest quality / Multi-grade oils
- Oil category 3.1: Multi-grade oils with a low ash-forming additive content (low SAPS oils)

Low SAPS oils are oils with a low sulfur and phosphor content and an ash-forming additive content of $\leq 1\%$.

They are only approved if the sulfur content in the fuel does not exceed 50 mg/kg. When using diesel particulate filters, it is advisable to use these oils to avoid fast coating of the filter with ash particles. For exceptions, see (→ Page 11).

Selection of a suitable engine oil is based on fuel quality, projected oil drain interval and on-site climatic conditions. At present there is no international industrial standard which alone takes into account all these criteria.

Important

The use of engine oils not approved by Rolls-Royce Solutions can mean that statutory emission limits can no longer be observed. This can be a punishable offense.

Important

Mixing different engine oils is strictly prohibited!
Changing to another approved oil grade can be done together with an oil change. The remaining oil quantity in the engine oil system is not critical in this regard.
This procedure also applies to the genuine Rolls-Royce Solutions engine oil grades in the regions Europe, Middle East, Africa, America and Asia.

Important

When changing to an engine oil in Category 3, note that the improved cleaning effect of these engine oils can result in the loosening of engine contaminants (e.g. carbon deposits).
It may be necessary therefore to reduce the oil change interval and oil filter service life (one time during change).

Special features

mtu ValueCare diesel engine oils

The following single and multi-grade oils are available from Rolls-Royce Solutions in the various regions:

Manufacturer & sales region	Product name	SAE grade	Oil category	Material number
Rolls-Royce Solutions Europe Middle East Africa	Diesel Engine Oil DEO SAE 15W-40	15W-40	2	20 l canister: X00070830 210 l barrel: X00070832 IBC: X00070833 Loose items: X00070835 (only on request)
	Power Guard® DEO SAE 40	40	2	20 l canister: X00062816 210 l barrel: X00062817 IBC: X00064829
Rolls-Royce Solutions America Inc. Americas	Power Guard® SAE 15W-40 Off Highway Heavy Duty	15W-40	2.1	5 gallons: 800133 55 gallons: 800134 IBC: 800135
	Power Guard® SAE 40 Off Highway Heavy Duty	40	2	5 gallons: 23532941 55 gallons: 23532942
Rolls-Royce Solutions Asia Asia	Diesel Engine Oil DEO SAE 15-W40	15W-40	2	20 l canister: 64242/P 205 l barrel: 65151/D
Rolls-Royce Solutions Suzhou Co. Ltd. China	Diesel Engine Oil - DEO 15W-40	15W-40	2	20 l canister: 64242/P 205 l barrel: 65151/D
	Diesel Engine Oil - DEO 10W-40	10W-40	2	20 l canister: 60606/P
PT. Rolls-Royce Solutions Indonesia Indonesia	Diesel Engine Oil - DEO 15W-40	15W-40	2	20 l canister: 64242/P 205 l barrel: 65151/D
mtu India Pvt. Ltd. India	Diesel Engine Oil - DEO 15W-40	15W-40	2	20 l canister: 63333/P 205 l barrel: 65151/P
	Diesel Engine Oil - DEO 40	40	2	20 l canister: 73333/P 205 l barrel: 75151/D

Table 2:

Restrictions for applications with Series 2000 and 4000 engines

Series 2000: Cx6, Gx6, Gx7, M41A IMO III, Mx6, M84, M94, Mx7, Sx6

Series 4000-03 Genset (all application groups), 4000: M73-M93L, N43 and N83, 4000-04 C&I, 4000-04 Genset (all application groups), 4000-04 Marine, 4000-04 Oil&Gas, 4000-04 Rail, 4000-05 C&I, 4000-05 Genset (all application groups), 4000-05 Oil&Gas

Important

Oils of oil category 1 must not be used!
Exception: Genset application group 3A and Bx4x.

Restrictions for applications with Series 2000 M72 engines

Important

Mobil Delvac 1630/1640, Mobilgard ADL 30/40 and Power Guard® SAE 40 Off-Highway Heavy Duty must not be used!

Restrictions for applications with Series 4000 C, R, T engines

Important

In the Series 4000 engine models C64, Cx5, T94, T94L and Tx5, only engine oils of oil category 3 or 3.1 of SAE grades 5W-40, 10W-40 or 15W-40 must be used!

Exceptions:

- For Series 4000 T, Chevron Delo 400 LE SAE 15W-40 (oil category 2.1) can also be used.
- For Series 4000 T, Fleet Supreme EC SAE 15W-40 (oil category 2.1) can also be used.

In engines in Series 4000 R64, R74 and R84, only engine oils of oil category 3.1 of SAE grades 5W-40 or 10W-40 must be used!

The maximum oil service life is 1000 operating hours with observance of the analytical limit values for used oils!

Restrictions for applications with Series 8000 engines

Important

Only the following engine oils may be used:

- Castrol HLX SAE 30 / SAE 40
- Chevron Delo 400 SAE 30 / SAE 40
- Exxon Mobil Delvac 1630 SAE 30
- Exxon Mobil Delvac 1640 SAE 40
- Mobilgard ADL 30 SAE 30
- Mobilgard ADL 40 SAE 40
- PowerGuard® SAE 40 Off-Highway Heavy Duty (material number: 5 gallons 23532941; 55 gallons 23532942)
- Shell Sirius X SAE 30 / SAE 40

Important

SAE grade 40 engine oils may only be used in combination with preheating and oil priming ($T_{oil} > 30 \text{ }^{\circ}\text{C}$).

Restrictions for applications with Series S60 engines

Important

Only multi-grade oils of SAE grade 15W-40 marked with index ²⁾ must be used.

The maximum oil service life is 250 operating hours or 1 year.

Restrictions when using low SAPS oils

Important

Oil Categories 2.1 and 3.1 may be used if the sulfur content in the fuel does not exceed 50 mg/kg.
For exceptions, see (→ Page 11)

Restrictions for applications with Series 595 and Series 1163-01, 1163-02 engines

Important

Category 2 or Category 3 oils are normally stipulated for fast commercial ferries using Series 595, 1163-01 and 1163-02 engines.

Restrictions for applications with Series 956 TB31 / TB32 / TB33 / TB34 and 1163 TB32 engines

Important

Engine oils of oil categories 1, 2.1 and 3.1 are generally not approved!

Only the following engine oils are currently approved for Series 956 TB 31, TB 32, TB 33, TB 34 engines for nuclear power station applications and for Series 1163-02 TB32 engines.

Series	Oil category 2, single-grade oil	Oil category 2, multi-grade oil	Oil category 3
956 TB 31	Power Guard® SAE 40 Off-Highway Heavy Duty Mobil Delvac 1630 Mobil Delvac 1640 Mobilgard ADL 30 SAE 30 Mobilgard ADL 40 SAE 40	Not approved	Shell Rimula R6 MS SAE 10W-40 Shell Rimula R6 M SAE 10W-40
956 TB 32	Power Guard® SAE 40 Off-Highway Heavy Duty Mobil Delvac 1640 Mobilgard ADL 40 SAE 40	Not approved	Shell Rimula R6 MS SAE 10W-40 Shell Rimula R6 M SAE 10W-40
956 TB 33 ε = 9	Power Guard® SAE 40 Off-Highway Heavy Duty Mobil Delvac 1640 Mobilgard ADL 40 SAE 40	Not approved	Shell Rimula R6 MS SAE 10W-40 Shell Rimula R6 M SAE 10W-40
956 TB 33 ε = 12	Power Guard® SAE 40 Off-Highway Heavy Duty Mobil Delvac 1640 Mobilgard ADL 40 SAE 40 Shell Sirius X 30	Lukoil Avantgarde Ultra NP 15W40	Shell Rimula R6 MS SAE 10W-40 Shell Rimula R6 M SAE 10W-40
956 TB 34	Power Guard® SAE 40 Off-Highway Heavy Duty Mobil Delvac 1640 Mobilgard ADL 40 SAE 40	Lukoil Avantgarde Ultra NP 15W40	Shell Rimula R6 MS SAE 10W-40 Shell Rimula R6 M SAE 10W-40
1163-02 TB 32 Emergency power, gen-set	Power Guard® SAE 40 Off-Highway Heavy Duty Mobil Delvac 1640 Mobilgard ADL 40 SAE 40 Shell Sirius X 30	Not approved	Shell Rimula R6 MS SAE 10W-40 Shell Rimula R6 M SAE 10W-40

Table 3:

Engine oil approvals upon customer request for applications in Series 956 TB 31, TB32, TB33, TB34

The engine oil must have a valid Rolls-Royce Solutions approval as per MTL 5044 and a quality level of oil category 2 or 3.

For customer certification, an engine test run under the following conditions is required: Individual cylinder test run 50 hours; with positive findings the engine test run has to be carried out as follows:

- Engine runtime with specific oil: min. 50 hours (30 hours of which at min. 100% power)
- Then endoscopic examination of combustion chambers.
- Disassembly of 4 pistons (2 on engine A-side and 2 on engine B-side) for detailed results.

Use of Low SAPS oils (oil categories 2.1 and 3.1) with fuels with a maximum sulfur content of 1000 mg/kg in applications in Series 12V2000M41A, 2000Mx7, 4000M03 IMO II/III, 4000M05 IMO II/III, 8V4000M63 IMO III and 20V4000M53B IMO III

If Low SAPS oils of oil categories 2.1 and 3.1 are to be used in conjunction with fuels with a maximum sulfur content of 1000 ppm, in addition to the Rolls-Royce Solutions approvals they must also comply with the following performance requirements:

Oil category	Specification	
	ACEA	API
2.1	E7 and E9	CJ-4 and CI-4
3.1	E6 and E7	CI-4

Table 4:

If the Low SAPS oils meet the above-mentioned requirements, they are approved for a runtime up to 500 operating hours. If the maximum runtime is exceeded, the base number of the oil must be checked through regular oil analyses. If the permissible base number is not reached, the oil must be replaced.

Important

If the performance requirements listed in the table are not met, only fuels with a max. sulfur content of 50 ppm must be used.

Engine oils for engines with exhaust gas aftertreatment (EGAT)

Engines with exhaust gas aftertreatment place special demands on the oils used to guarantee the operational reliability and service life of the exhaust system and the engine.

Depending on the technology used for exhaust gas aftertreatment, the following oils can be used.

Exhaust gas technology	Approval for oil category				
	1	2	2.1	3	3.1
Oxidation catalyst without particulate filter	no	no	yes	no	yes
SCR system with vanadium catalysts (no particulate filter)	no	no	yes	no	yes
SCR system with zeolite catalysts (no particulate filter)	no	no	yes	no	yes
Closed particulate filter	no	no	yes	no	yes
Combination system SCR+ particulate filter	no	no	yes	no	yes

Table 5:

Important

The use of engine oils of categories 1, 2 and 3 (with ash content >1%) on plants with EGAT results in a significantly reduced service life of the EGAT system and, with particulate filters, increased back pressure.

Important

For EPA Tier 4i or Tier 4 and EU IIIb-certified engines with exhaust gas aftertreatment, only low-ash engine oils of category 2.1 or 3.1 are permitted.

Any possible restrictions related to engine requirements must also be observed.

Assignment of military engine oil specifications to SAE viscosity grades

NATO code	Country-specific specifications	SAE grade
O-236	TL 9150-0063	Multi-grade oil SAE 15W-40, can also be used as corrosion inhibitor oil
O-278 OMD 113	TL 9150-0031 DEF STAN 91-22 DCESEA 278/A MIL-PRF-9000L	Single-grade oil SAE 40
O-1178 OMD 55	TL 9150-0080	Multi-grade oil SAE 5W-30 (low-temperature properties better than 5W)
O-1176 OMD 90	DEF STAN 91-113	Multi-grade oil SAE 10W-30
O-1180	TL 9150-0107	Multi-grade oil SAE 10W-40 (Low SAPS)

Table 6:

Selection of viscosity grades

Selection of the viscosity grade is based primarily on the ambient temperature at which the engine is to be started and operated. If the relevant performance criteria are observed the engines can be operated both with single-grade and multi-grade oils, depending on the application. Standard values for the temperature limits in each viscosity grade are shown in (→ Figure 1).

If the prevailing temperature is too low, the engine oil must be preheated.

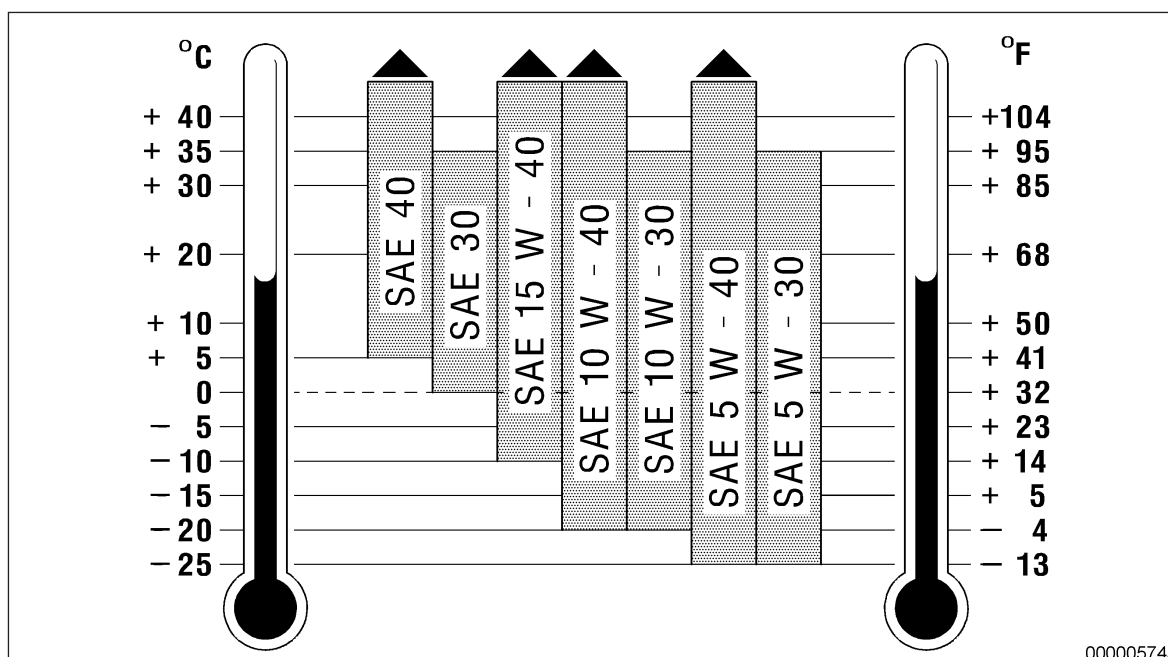

Figure 1: Viscosity grade chart

TIM-ID: 0000018560 - 008

00000574a

Oil drain intervals for diesel engines

Engine oil drain intervals depend on the engine-oil quality, its conditioning, the operating conditions and the fuel used.

The intervals quoted (Table) are guidelines based on operational experience and are valid for applications with a standard load profile.

Oil change intervals

Oil category	Without centrifugal oil filter	With centrifugal oil filter or bypass oil filter
1	250 operating hours	500 operating hours
2	500 operating hours	1000 operating hours
2.1 ¹⁾	500 operating hours	1000 operating hours
3	750 operating hours	1500 operating hours
3.1 ¹⁾	750 operating hours	1500 operating hours

Table 7:

¹⁾ = To be used in conjunction with fuels with max. 50 mg/kg sulfur content

For exceptions, see (→ Page 11)

Important

The oil change intervals in the table (→ Table 7) are recommended guidelines when using diesel fuels with < 0.5% sulfur content. The defined limit values for the used oil (→ Table 8) must be observed. The numbers of operating hours quoted for oils must be confirmed by means of oil analysis.

The oil drain intervals must be determined by oil analysis if one or more of the following difficult operating conditions are encountered:

- Extreme climatic conditions
- High engine start-up frequency
- Frequent and prolonged idling or low-load operation
- High fuel sulfur content of 0.5 to 1.5% by weight (see “Use of High-Sulfur Fuel”)

For applications involving low runtimes, the engine oil must be changed every two years at the latest irrespective of its category.

Where engine oils with higher-grade corrosion-inhibiting characteristics are in use, a change must be carried out every 3 years at the latest.

In individual cases the service life of the engine oil can be optimized by regular laboratory analysis and appropriate engine inspections in consultation with the responsible Rolls-Royce Solutions service point:

The first oil sample should be taken from the engine as a “basic sample” after the engine has run for approximately 1 hour after being filled with fresh oil.

Further samples are to be analyzed at specific intervals (see “Laboratory Analysis”).

The appropriate engine inspections are to be carried out before and after the oil analyses.

After completion of all analyses, and depending on the findings, special agreements can be reached for individual cases.

Oil samples must always be taken under the same conditions and at the point provided for that purpose (see Operating Instructions).

Special additives

Approved engine oils have been specially developed for diesel engines and have all necessary properties. Further additives are therefore superfluous and may even be harmful.

Laboratory analysis

Spectrometric oil analysis

Analysis of the engine oil's additive-metal content is carried out by the Rolls-Royce Solutions laboratory to determine the oil brand.

Analyses of the wear-metal content to determine the degree of engine wear are not part of the standard procedure. These content levels are very much dependent on the following factors, among others:

- Individual engine equipment status
- Tolerance scatter
- Operating conditions
- Duty profile
- Fluids and lubricants
- Miscellaneous assembly materials

Unambiguous conclusions as to the wear status of the engine components involved are therefore not possible. This means that no limit values can be given for wear-metal contents.

The measurement of the wear-metal element contents can only be regarded as a monitoring task. A sudden increase is an indication to check/inspect the oil filter. If wear particles are found, and EDX analysis can determine their composition, which helps to identify the affected component.

Used-oil analysis

In order to check the used oil, it is recommended that regular oil analyses be carried out. Oil samples should be taken and analyzed at least once per year and during each oil change and under certain conditions, depending on application and the engine's operating conditions, sampling / analysis should take place more frequently.

The specified test methods and limit values (Analytical Limit Values for Used Diesel Engine Oils) (→ Table 8) indicate when the results of an individual oil sample analysis are to be regarded as abnormal.

An abnormal result requires immediate investigation and remedy of the abnormality.

The limit values relate to individual oil samples. When these limit values are reached or exceeded, an immediate oil change is necessary. The results of the oil analysis do not necessarily give an indication of the wear status of particular components.

In addition to the analytical limit values, the engine condition, its operating condition and any operational faults are decisive factors with regard to oil changes.

Some of the signs of oil deterioration are:

- Abnormally heavy deposits or precipitates in the engine or engine-mounted parts such as filters, centrifugal filters or separators, especially in comparison with the previous analysis.
- Abnormal discoloration of components.

Analytical limit values for used diesel engine oils

	Test method	Limit values	
Viscosity at 100 °C max. mm ² /s	ASTM D445 DIN 51562 DIN 51659-1 DIN 51659-2 DIN 51659-3	SAE 30	15.0
		SAE 5W-30 SAE 10W-30	
min. mm ² /s		SAE 40	19.0
		SAE 5W-40 SAE 10W-40 SAE 15W-40 SAE 20W-40	
		SAE 30	9.0
		SAE 5W-30	
		SAE 10W-30	

TIM-ID: 0000018560 - 008

	Test method	Limit values
		SAE 40 SAE 5W-40 10.5 SAE 10W-40 SAE 15W-40 SAE 20W-40
Flashpoint °C (COC)	ASTM D92 DIN EN ISO 2592	Min. 190
Flashpoint °C (PM)	ASTM D93 DIN EN ISO 2719	Min. 140
Soot content (by weight %)	DIN 51452 CEC-L-82-97	Max. 3.0 (Oil category 1) Max. 3.5 (Oil category 2, 2.1, 3 and 3.1)
Total base number (mg KOH/g)	ASTM D2896 ISO 3771 DIN 51639	Min. 50% of new-oil value
Water content (mg/kg)	ASTM D6304 EN 12937 ISO 6296	Max. 2000
Oxidation (A/cm) ¹⁾	DIN 51453 ¹⁾	Max. 25
Ethylene glycol (mg/kg)	ASTM D2982	max. difference between new-oil value and used-oil value 100
Additive element contents	DIN 51399-1 DIN 51399-2 ASTM D5185	To confirm that the new oil is identical with the oil grade of the used oils

Table 8:

¹⁾ = only possible if there are no ester compounds

Use of high-sulfur diesel fuel

The following measures must be taken in the case of diesel fuels with a sulfur content above 0.5%:

- Use of an engine oil with a total base number (TBN) of more than 8 mgKOH/g
- Shorten the oil-change intervals (see Oil change intervals)
- Shorter TBO of cylinder heads on Series 4000 engines (→ Page 38)

Chart (→ Figure 2) (Total Base Numbers) lists the recommended minimum total base numbers for new and used oils depending on the sulfur content of the diesel fuel.

The total base numbers for the approved engine oils are listed in chapter Approved engine oils (→ Page 107).

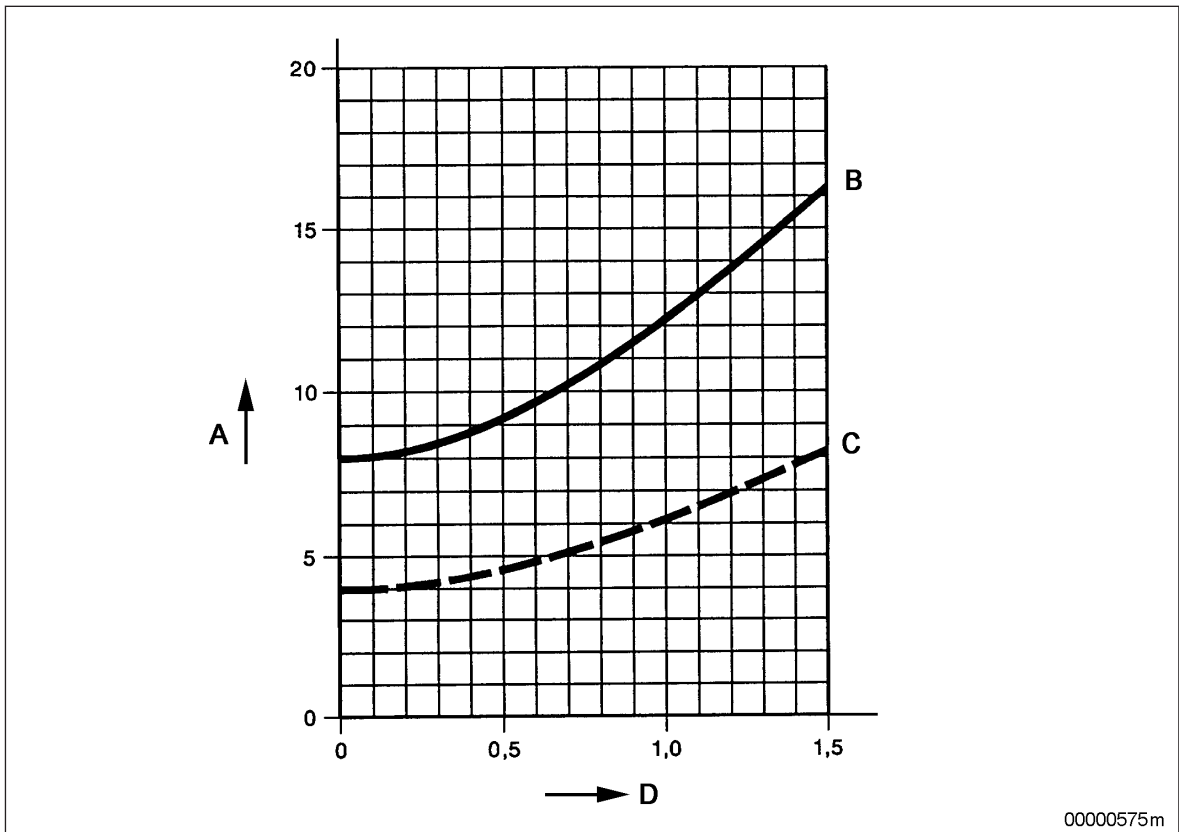

Figure 2: Total base number for engine oil depending on sulfur content of the diesel fuel

- | | |
|--|---------------------------------------|
| A Total base number in mgKOH/g, ISO 3771 | C Min. total base number for used oil |
| B Recommended min. total base number for fresh oil | D Sulfur content of fuel in % weight |

Use of low-sulfur diesel fuel

The use of diesel fuels with low sulfur content (< 0.5%) does not influence the oil drain intervals.

Minimum requirements for operational checks

Oil analyses can be carried out using the mtu test kit. The mtu test kit contains all the equipment required as well as instructions for use.

The following checks can be performed:

- Determination of oil dispersancy (spot test)
- Determination of diesel fuel content in oil
- Determination of water content in oil

2.2 Fluorescent dyestuffs for detecting leaks in the lube oil circuit

The fluorescent dyestuffs listed below are approved for detection of leaks in the lube oil circuit.

Manufacturer	Product name	Working concentration	Material number	Container size	Storage stability ¹⁾
Chromatech Europe B.V.	D51000A Chromatint Fluorescent Yellow 175	0.04 % - 0.07 %	X00067084	16 kg	2 years
Cimcool, Cincinnati	Producto YFD-100	0,5 % - 1,0 %		5 gallons (canister) 55 gallons (barrel)	6 months

Table 9:

¹⁾ = ex works delivery, based on original and hermetically sealed containers in frost-free storage (> 5 °C).

The fluorescence (light-yellow color tone) of both dyestuffs is made visible with a UV lamp (365 nm).

2.3 Lubricating greases

Requirements

The conditions of Rolls-Royce Solutions for the approval of lubricating greases are specified in the delivery standard MTL 5050, which can be ordered under this reference number.

Grease manufacturers are notified in writing if their product is approved.

Lubricating greases for general applications

Lithium-saponified greases are to be used for all lubrication points with the exception of:

- Emergency air-shutoff flaps installed between exhaust turbocharger and intercooler (see Special-purpose lubricants)
- Coupling internal centering

Lubricating greases for applications at high temperatures

High-temperature grease (up to 250 °C) must be used for emergency air-shutoff flaps installed between exhaust turbocharger and intercooler:

- Castrol Braycote Inertox 500-2

General purpose greases suffice for emergency air-shutoff flaps installed before the exhaust turbocharger or after the intercooler.

Greases for internal centerings of couplings

Greases for internal centerings:

- Esso Unirex N3 (stable up to approx. 160 °C)

Special-purpose lubricants

Oils for exhaust turbochargers

Exhaust turbochargers with integrated oil supply are generally connected to the engine oil system.

For ABB exhaust turbochargers which are not connected to the engine lube oil system, mineral-based turbine oils with viscosity grade ISO-VG 68 must be used.

Lubricants for curved tooth couplings

Depending on the application, the following lubricants have been approved for curved tooth couplings:

- - Klüber: Structovis BHD MF (highly viscous lube oil)
- - Klüber: Klüberplex GE11-680 (adhesive transmission lubricant)

Guidelines on use and service life of the various lubricants are contained in the relevant Operating Instructions and Maintenance Schedules.

3 Lubricants for Two-Cycle Engines

3.1 Engine oils

Important

Dispose of used fluids and lubricants in accordance with local regulations.
Used oil must never be disposed of via the fuel tank!

Engine oil requirements for two-stroke cycle engines of Series 53/71/92 and 149

Specification	Test Method		SAE grade	
	ASTM	ISO	40 Limit values	50 Limit values
API CF-2				
Viscosity at 100 °C (mm ² /s)	D445	EN 3104 DIN 51562 DIN 51569-1	12.5 - 16.3	16.3 - 21.9
Viscosity at 40 °C (mm ² /s)	D445	EN 3104 DIN 51562 DIN 51569-1	130 - 150	200 - 300
Pour point (°C)	D97	3016	Max. -15	Max. -10
Flashpoint (°C)	D92	2592	Min. 225	Min. 230
Sulfated ash (by weight %)	D874	DIN 51575	Max. 1.0	Max. 0.8
Total base number (mgKOH/g)	D2896	3771	7.0 - 10.0	Min. 7.0
Calcium (mg/kg)	D5185	DIN 51399-1/-2	No limit value	Max. 500
Phosphor mg/kg	D5185	DIN 51399-1/-2	Min. 700	Max. 100
Zinc (mg/kg)	D5185	DIN 51399-1/-2	Min. 700	Max. 100

Table 10:

Special features

The following listed two-stroke cycle engine oils are available at Rolls-Royce Solutions America Inc.:

mtu engine oils for two-stroke cycle engines

Manufacturer & sales region	Product name	SAE grade	Specification	Comments / material number
Rolls-Royce Solutions America Inc. Americas	PowerGuard® Heavy Duty Engine Oil for Detroit Diesel 2-Cycle (4x1G) SAE 40	40	API CF-2	4x1 gallons: 23512701
	PowerGuard® Heavy Duty Engine Oil for Detroit Diesel 2-Cycle SAE 40	40	API CF-2	5 gallons: 23512734 55 gallons: 23512702 IBC: 23512739

Table 11:

Restrictions for Series 53/71/92 applications – all applications except Marine

Important

Start failures may occur at ambient temperatures $< 0\text{ }^{\circ}\text{C}$ when the engine is operated with SAE grade 40 oils.

If no start aids are available, oils of SAE grade 30 may be used as a short-term solution. At lower temperatures (-18 to $-32\text{ }^{\circ}\text{C}$) oils of SAE grade 15W-40 may also be used. These oils must, however, comply with the specification API CF-2 and have a high-temperature viscosity of min. 3.7 cP at $150\text{ }^{\circ}\text{C}$.

The oil grade must be changed back to SAE 40 as soon as the temperatures allow to do so.

Restrictions for Series 53/71/92 marine applications

Important

No single-grade oils of SAE grade 30 or multi-grade oils must be used!

Restrictions for Series 53/71/92 applications

Important

For applications with coolant outlet temperatures $> 94\text{ }^{\circ}\text{C}$, oils of SAE grade 50 must be used!

If fuels with low-sulfur content of 0.5 to 1.0% are used, the oil service life is shortened.

Restrictions for Series 149 applications

Important

For applications with ambient temperatures $> 35\text{ }^{\circ}\text{C}$, oils of SAE grade 50 must be used!

Oil of SAE grade 50 can no longer be recommended at ambient temperatures $< 7\text{ }^{\circ}\text{C}$.

If starting speed is no longer reached with the use of SAE grade 50 oils, oil from SAE grade 40 can also be used.

No single-grade oils of SAE grade 30 or multi-grade oils must be used!

If fuel with a sulfur content of between 0.5 and 1% are used, oils with a base number of at least 10 mg/KOH/g and with zinc and phosphor contents of max. 100 mg/kg must be used!

Analytical limit values for used diesel two-stroke cycle engine oils

	ASTM	ISO	Limit value SAE 40	Limit value SAE 50
Viscosity at $100\text{ }^{\circ}\text{C}$ (mm^2/s)	D445	EN 3104 DIN 51562 DIN 51569-1	Min. 12.5 Max. 16.3	Min. 16.0 Max. 22.0
Soot content (by weight %)	E 1131	DIN 51452 ¹⁾	Max. 0.8	Max. 0.8
Water (% by vol.)	D1744	EN 12937	Max. 0.3	Max. 0.3
Ethylene glycol	D2982	DIN 51375	Negative	Negative
Iron (mg/kg)	ASTM D5185	DIN 51399-1/-2	Max. 150	Max. 35
Aluminum, silicon, copper (mg/kg)	ASTM D5185	DIN 51399-1/-2	Max. 25	Max. 25
Lead (mg/kg)	ASTM D5185	DIN 51399-1/-2	max. 10	max. 10

Table 12:

¹⁾ = The standard can be used provided that the test procedure for determining the soot content is calibrated such that equivalent results to the thermographic analysis (TGA) according to ASTM E 1131 are produced.

Oil change intervals with use of fuels with sulfur content < 0.5%

Application	Series	Oil change interval
C&I, Marine	S 53/71/92	150 h or 1 year
C&I, Marine	S 149	300 h or 1 year
Generator – emergency power	S 53/71/92/149	150 h or 6 months
Generator – continuous operation	S 53/71/92/149	150 h or 3 months

Table 13:

4 Coolants

4.1 General information

Coolant definition

Coolant = coolant additive (concentrate) + freshwater in a predefined mixing ratio ready for use in the engine.

The corrosion-inhibiting effect of coolant is only ensured with the coolant circuit fully filled. The only exception is Oil 9 156, which maintains its corrosion-inhibiting character even when the coolant was drained due to oil-film formation in the circuit.

Apart from that, only the corrosion inhibitors approved for internal preservation of the coolant circuit provide proper corrosion protection when the medium was drained. This means that after draining the coolant the cooling circuit must be preserved if no more coolant is to be filled. For the preservation procedure, refer to the Preservation and Represervation Specifications A001070/.. of the engine.

Coolants must be prepared from suitable freshwater and a coolant additive approved by Rolls-Royce Solutions. Conditioning of the coolant takes place outside the engine.

Important

Mixtures of various coolant additives and supplementary additives (also in coolant filters and filters downstream of plant components) are not permitted!

The conditions for the approval of coolant additives are specified in the following delivery standards (MTL):

- MTL 5047: Emulsifiable corrosion inhibitor oils
- MTL 5048 antifreeze
- MTL 5049: Water-soluble corrosion inhibitors

Coolant manufacturers are informed in writing if their product is approved.

To prevent cooling system damage:

- When topping up (following loss of coolant) it must be ensured that not only water but also concentrate is added. The specified antifreeze and/or corrosion inhibitor concentration must be maintained.
- The corrosion inhibitor concentration must not exceed 55 % by volume (max. antifreeze protection). Concentrations in excess of this reduce antifreeze protection and heat dissipation.
- The coolant must not contain any oil or copper residue (in solid or dissolved form).
- The majority of corrosion inhibitors currently approved for internal coolant circuit preservation are water-soluble and do not provide antifreeze protection. Make sure that the engine is stored safe from frost, because a certain amount of coolant remains in the engine after draining.
- A coolant circuit can not usually be drained completely, i.e. residual quantities of used coolant or freshwater from a flushing procedure remain in the engine. These residual quantities can result in the dilution of a coolant to be filled (mixed from a concentrate or use of a ready mixture). This dilution effect is higher the more add-on components there are on the engine. Check the coolant concentration in the coolant circuit and adapt it if necessary.

Important

All coolants approved in these Fluids and Lubricants Specifications generally relate only to the coolant circuit of mtu engines. In the case of complete propulsion systems, the operating fluids approvals of the component manufacturer must be observed!

Important

For corrosion-related reasons, it is not permissible to operate an engine with pure water without the addition of an approved corrosion inhibitor!

Special features

mtu ValueCare – coolants and premixes

The following mtu ValueCare products are available from Rolls-Royce Solutions:

Manufacturer & sales region	Product name	Material number
Rolls-Royce Solutions GmbH, Rolls-Royce Solutions Asia Europe Middle East Africa Asia	Antifreeze	
	Coolant AH 100 Antifreeze Concentrate	X00057231 (20 l) X00057230 (210 l)
	Coolant AH 50/50 Antifreeze Premix	X00070528 (20 l) X00070527 (1000 l) (Sales region: England)
	Coolant AH 40/60 Antifreeze Premix	X00070533 (20 l) X00070532 (1000 l) (Sales region: England, Spain)
	Coolant AH 35/65 Antifreeze Premix	X00069382 (20 l) X00069383 (210 l) X00069384 (1000 l) (Sales region: Italy)
	Coolant without antifreeze	
	Coolant CS 100 Corrosion Inhibitor Concentrate	X00057233 (20 l) X00057232 (210 l)
	Coolant CS 10/90 Corrosion Inhibitor Premix	X00069385 (20 l) X00069386 (210 l) (Sales region: Italy)
	Rolls-Royce Solutions America Inc. Americas	Antifreeze
Power Cool® Off-Highway Coolant 50/50 Premix		23533531 (5 gallons) 23533532 (55 gallons)
Power Cool® Universal 50/50 mix		800069 (1 gallon) 800071 (5 gallons) 800084 (55 gallons)
Power Cool® Universal 35/65 mix		800085 (5 gallons) 800086 (55 gallons)
Power Cool® 3149 Concentrate		23528572 (55 gallons) 23528571 (1000 l)
Coolant without antifreeze		
Power Cool® Plus 6000 Concentrate		23533526 (1 gallon) 23533527 (5 gallons) colored green

Table 14:

Note:

For ready mixtures, the proportion of coolant additive (concentrate) is always named first. Example:

- Coolant AH 40/60 Antifreeze Premix = 40% by vol. coolant additive / 60% by vol. freshwater

4.2 Unsuitable materials in the coolant circuit

Components made of copper, zinc and brass materials

Unless various preconditions are observed, components made of copper, zinc and brass materials in the coolant circuit can cause an electrochemical reaction in conjunction with base metals (e.g. aluminum). As a result, components made of base metals are subject to corrosion or even corrosive pitting. The coolant circuit becomes leaky at these points.

Requirements

Based on current knowledge, the following materials and coatings must not be used in an engine coolant circuit because negative mutual reactions can occur even with approved coolant additives.

Metallic materials

- No galvanized surfaces
The entire cooling system must be free of zinc components. This also applies to coolant supply and drain lines as well as to storage containers
- No copper-based alloys as material with the use of coolant containing nitrite, with the exception of the following two alloys:
 - CuNi10Fe1Mn corresponds to CW-352-H
 - CuNi30Mn1Fe corresponds to CW-354-H
- Do not use components containing brass in the coolant circuit (e.g. coolers made of CuZn30) if exposed to ammoniacal solutions (e.g. amines, ammonium, ...) and solutions containing nitrite or sulfide. Stress-corrosion cracking is possible in the presence of tensile stress and a critical potential area. "Solutions" refer to cleaning agents, coolants and similar substances.
- Avoid copper materials wherever possible or keep their effective surface area to the bare minimum. If copper materials cannot be avoided, purely organically inhibited coolants from the list of approved coolants should be used wherever possible.

Non-metallic materials

- Do not use EPDM or silicone elastomers if emulsifiable corrosion inhibitor oils are used or other oils are introduced to the coolant circuit.

Coolant filter / filter downstream of plant components

- If such filters are used, only products that do not contain additives may be used.
Supplementary additives such as silicates, nitrites etc. can diminish the protective effect or useful life of a coolant and, possibly, attack the materials installed in the coolant circuit.

Information:

Consult the relevant Rolls-Royce Solutions specialist department in case of doubt about the use of materials on the engine / externally mounted components in coolant circuits.

4.3 Requirements imposed on freshwater

Only clean, clear water with values in accordance with those in the following table must be used for preparing the coolant. If the limit values for the water are exceeded, hardness or mineral content can be decreased by adding demineralized water.

For preparation of coolant with and without antifreeze:

Item	Minimum	Maximum
Total earth alkalines ¹⁾ (Water hardness)	0 mmol/l 0°d	2.7 mmol/l 15°d
pH value at 20 °C	5.5	8.0
Chloride ions + fluoride ions		100 mg/l
Sulphate ions		100 mg/l
Bacteria		10 ³ CFU (colony forming unit)/ml
Fungi, yeasts	Not permitted!	

Table 15:

¹⁾ = Common designations for water hardness in various countries:

1 mmol/l = 5.6°d = 100 mg/kg CaCO₃

- 1°d = 17.9 mg/kg CaCO₃, USA hardness
- 1°d = 1.79° French hardness
- 1°d = 1.25° English hardness

For preparation of emulsifiable corrosion inhibitors:

Item	Minimum	Maximum
Total earth alkalines ¹⁾ (Water hardness)	0.36 mmol/l 2°d	1.8 mmol/l 10°d
pH value at 20 °C	7.0	8.0
Chloride ions + fluoride ions		100 mg/l
Sulphate ions		100 mg/l
Bacteria		10 ³ CFU (colony forming unit)/ml
Fungi, yeasts	Not permitted!	

Table 16:

¹⁾ = Common designations for water hardness in various countries:

1 mmol/l = 5.6°d = 100 mg/kg CaCO₃

- 1°d = 17.9 mg/kg CaCO₃, USA hardness
- 1°d = 1.79° French hardness
- 1°d = 1.25° English hardness

If the water is too soft, this can result in foam formation and the water has to be hardened before application by adding hard water. If the water is too hard, this impairs the emulsion stability. This causes increased oil separation and the formation of deposits in the system. Excessively hard water must therefore be softened by blending with soft water.

4.4 Emulsifiable corrosion inhibitor oils

Emulsifiable corrosion inhibitor oils

Emulsions of approved emulsifiable corrosion inhibitor oils (1.0 – 2.0% by volume) and suitable freshwater (→ Page 25) provide adequate corrosion protection.

However, they do not provide antifreeze protection.

A 2% by volume concentration must be used for initial filling.

The required quantity of corrosion inhibitor oil is best mixed in advance in a container with 4 to 5 times the amount of freshwater and then added to the coolant when the engine is running at operating temperature.

In maintenance stations or multi-engine installations, the complete amount of coolant required should be prepared in a separate container, it can then be used for initial filling or replenishment as required.

Important

Under unfavorable conditions, individual cases of bacterial attack may occur in the emulsifiable corrosion inhibitor oils. Treat the coolant emulsion with biocide in this case! Refer to chapter “Flushing and cleaning specifications for engine cooling circuits” (→ Page 192).

Note:

Slight precipitation may occur where coolant emulsions are used. This is shown by a layer on the surface of the coolant in the expansion tank. This is of no significance provided that the emulsion concentration remains within the specified limit values. Change the coolant in the event of a sudden drop in coolant additive concentration or if the additive is no longer absorbed. If necessary, the engine coolant chambers are to be cleaned, see the chapter “Flushing and cleaning specifications for engine coolant circuits” (→ Page 192).

Emulsifiable corrosion inhibitor oils must not be used in engines of the following series:

- Series 099
- Series 183
- Series 2000
- Series 396
- Series 4000
- Series S60
- Two-stroke cycle engines

Important

The series with application approval for emulsifiable corrosion inhibitor oils are listed in the chapter “Approved coolants” (→ Page 147).

For the following listed serial numbers of the Series 20V956TB33 up to year of manufacture end of 2008 (as per identification plate), only emulsifiable corrosion inhibitor oil must be used:

Serial number	Serial number	Serial number	Serial number	Serial number
5870001	5870002	5870003	5870004	5870005
5870006	5870007	5870008	5870009	5870010
5870011	5870012	5870013	5870014	5870015
5870016	5870017	5870018	5870019	

Table 17:

Special approvals presently in effect remain valid.

Important

The emulsifiable corrosion inhibitor oil must never be used for coolant temperatures >90 °C!

Flushing with water is required after every change to a different coolant product. For preserved engines (new engines, field engines, reserve stock engines, etc.), a flushing run must be carried out prior to filling with engine coolant. The necessary work is described in the chapter “Flushing and cleaning specifications for engine coolant circuits” (→ Page 192).

4.5 Antifreeze

The previous versions of these Fluids and Lubricants Specifications used the term “Corrosion-inhibiting anti-freeze”. The term “Antifreeze” is now used in this edition for reasons of clarity.

Antifreeze is necessary for engines without heating facilities and for operation in areas where below-freezing temperatures may occur.

The BASF SE Glysantin G206 product for Arctic regions is no longer available. Stocks of this product may be used up as long as the shelf life has not expired. Please contact your Rolls-Royce Solutions partner.

Most of the antifreezes approved by Rolls-Royce Solutions are based on ethylene glycol.

Approved antifreezes based on propylene glycol are listed in the relevant chapter (→ Page 191).

Provided that they are used in approved concentrations, antifreezes approved by Rolls-Royce Solutions provide effective protection against corrosion, see section “Operational monitoring” (→ Page 31).

The antifreeze concentration must be determined not only in accordance with the minimum anticipated temperatures but also with the corrosion protection requirements.

Important

For approved coolant additives for the individual engine series, refer to chapter “Approved coolants” (→ Page 147).

Special approvals presently in effect remain valid.

Important

Coolant additives containing nitrite must not be used in conjunction with coolers that contain brass!

Marine engines are subject to the following limitations when using antifreezes:

Series 538, 595 and 8000:

The use of antifreezes is not allowed for these engines.

Series 956-01, 956-02, 1163-02, 1163-03, 1163-04:

These engines are equipped with heating units. Because of their cooler capacity, antifreezes must not be used.

Series 099, 183, 396:

Antifreezes may be used with these engines at seawater temperatures up to a maximum of 20 °C max.

Series 2000 and 4000:

On these engines with installed heat exchanger, antifreezes may be used at seawater temperatures up to a maximum of 25 °C. The use of antifreezes is generally allowed on engines with no installed heat exchanger. Ensure that the heat exchanger not installed on the engine is sufficiently dimensioned.

The specified maximum values for the seawater temperatures apply to all engines on a vessel that are cooled with seawater, e.g. drive motor and onboard power generator.

Important

The maximum admissible antifreeze content for Series 2000, model types 00 to 07 in marine applications is limited to 40% by volume.

The possibility of using antifreezes for the above-mentioned series for other applications (e.g. genset, rail) is described in the overview in the chapter “Approved coolants”(→ Page 147).

Note:

Propylene glycol-based antifreezes are stipulated for use in some types of applications. These products have a lower thermal conductivity than the usual ethylene glycol products. This results in a higher temperature level in the engine.

Important

Propylene glycol based coolants (→ Page 191) are approved for Series 4000 model types 01 to 05 used in genset applications.

Restrictions apply to the use of propylene glycol based coolants for various model types in all other Series 4000 applications. See (→ Page 147)

Flushing with water is required at every change to a different coolant product. For preserved engines (new engines, field engines, reserve stock engines, etc.), a flushing run must be carried out prior to filling with engine coolant if the engines were preserved with an emulsifiable corrosion inhibitor. The necessary work is described in the chapter “Flushing and cleaning specifications for engine coolant circuits” (→ Page 192).

4.6 Coolant without antifreeze

The previous versions of these Fluids and Lubricants Specifications used the term “water-soluble corrosion inhibitors”. For reasons of clarity, this publication uses the term “Coolant without antifreeze”. Emulsifiable corrosion inhibitor oils are not covered in this chapter. See chapter “Emulsifiable corrosion inhibitor oils” (→ Page 26)

Coolant without antifreeze is required for higher coolant temperatures and large temperature drops in heat exchangers, e.g. in TB systems (with plate-core heat exchanger) and TE systems in Series 099, 183, 2000, 396 and 4000 engines.

Provided that they are used in adequate concentration, coolants without antifreeze approved by Rolls-Royce Solutions provide effective corrosion protection. The relevant concentration range for use is listed in the section on operational monitoring.

Important

For approved coolant additives for the individual engine series, refer to chapter “Approved coolants” (→ Page 147).

Special arrangements presently in effect remain valid.

Important

Coolant additives containing nitrite must not be used in conjunction with coolers that contain brass!

Flushing with water is required at every change to a different coolant product. For preserved engines (new engines, field engines, reserve stock engines, etc.), a flushing run must be carried out prior to filling with engine coolant if the engines were preserved with an emulsifiable corrosion inhibitor. The necessary work is described in the chapter “Flushing and cleaning specifications for engine coolant circuits” (→ Page 192).

4.7 Operational monitoring

Inspection of the freshwater and continuous monitoring of the coolant are essential for trouble-free engine operation. Freshwater and coolant should be checked at least once per year and with each fill-up. Inspections can be carried out using the mtu test kit, or by an authorized laboratory. The mtu test kit contains the necessary equipment, chemicals and instructions for use.

Analysis	Method for on-site checks (mtu test kit)	Method for lab analysis
Determination of the water hardness	Titration	Determination of the Ca and Mg content by means of ICP and calculation of the hardness in °dH or mmol/l
Determination of the pH value	Litmus paper strips for an appropriate measuring range	ASTM D 1287
Determination of the chloride content	Titration	IC
Determination of the sulfate content	-	IC
Determination of the silicon content	-	ICP
Determination of additive concentration in aqueous coolant solutions	Brix refractometer, compare degree(s) Brix against table (→ Table 20) and read off concentration in % by volume	Refractometer method DIN 51423, compare Brix degree against table (→ Table 20) and read off concentration in % by volume
Determination of antifreeze concentration	Glycol refractometer, concentration in % by volume can be read off directly	Refractometer method DIN 51423, calculation through refraction index or product-specific factor
Determination of germ total for aqueous media	-	Dip slides (tube with culture medium, e.g. by VWR Prolabo No. 535112D or equivalent) incubation time: 4 days at 30 °C

Table 18: Minimum requirements and methodology for coolant monitoring

Orders for freshwater and coolant analysis may be placed with Rolls-Royce Solutions. In particular cases, operational monitoring can cover more checks than those listed in table (→ Table 18). Please contact your Rolls-Royce Solutions partner if necessary.

Important

On Series 4000-04/-05 engines, an additional exhaust gas cooler is installed and the cooling system reacts more sensitively. A regular check of the coolant is therefore very important to ensure trouble-free engine operation. This check must be carried out annually or after 3000 operating hours and every time the coolant is filled.

The concentration, pH value and silicon content (only with coolants that contain Si) must be within the values specified in these Fluids and Lubricants Specifications.

Important

Due to thermal stress of the coolant in plants with preheating, a semi-annual analysis of the coolant is recommended.

Permissible concentrations

	Minimum				Maximum
Emulsifiable corrosion inhibitor oils without antifreeze	1% by volume	-	-	-	2% by volume
Antifreeze on ethylene glycol basis	35% by volume	40% by volume	45% by volume	50% by volume	55% by volume
with antifreeze protection up to*	-20 °C	-25 °C	-31 °C	-37 °C	-45 °C
Antifreeze on propylene glycol-basis	35% by volume	-	-	-	50% by volume
with antifreeze protection up to*	-18 °C	-	-	-	-32 °C

Table 19:

* = Antifreeze specifications determined as per ASTM D 1177

Note:

Concentration ratios may be subject to certain restrictions depending on the customer, Series, model type and application concerned (refer to the Operating Instructions of the engine).

Operational monitoring for permissible concentrations, coolant without antifreeze

Permissible concentration range	Manufacturer	Product name / brand name	Reading on hand refractometer ¹ at 20 °C (= degrees Brix)					
			% by vol.	7	8	9	10	11
9 to 11% by volume	Rolls-Royce Solutions	Coolant CS 100 Corrosion Inhibitor Concentrate	3.5	4.0	4.5	5.0	5.5	6.0
		Coolant CS 10/90 Corrosion Inhibitor Premix	3.5	4.0	4.5	5.0	5.5	6.0
	Rolls-Royce Solutions America Inc.	Power Cool® Plus 6000	3.5	4.0	4.5	5.0	5.5	6.0
	Arteco	Freecor NBI	Please use test kit of manufacturer					
	BASF SE	Glysacorr G93 green	3.5	4.0	4.5	5.0	5.5	6.0
	CCI Corporation	A 216	4.9	5.6	6.3	7.0	7.7	8.4
	CCI Manufacturing IL Corporation	A 216	4.9	5.6	6.3	7.0	7.7	8.4
	Chevron	Texcool A -200	Please use test kit of manufacturer					
	Detroit Diesel Corporation	Power Cool Plus 6000	4.9	5.6	6.3	7.0	7.7	8.4
	Drew Marine	Drewgard XTA	3.5	4.0	4.5	5.0	5.5	6.0
	ExxonMobil	Mobil Delvac Extended Life Corrosion Inhibitor	4.9	5.6	6.3	7.0	7.7	8.4
	Ginouves	York 719	3.5	4.0	4.5	5.0	5.5	6.0
	Old World Industries Inc.	Final Charge Extended Life Corrosion Inhibitor (A 216)	4.9	5.6	6.3	7.0	7.7	8.4
	Valvoline	Zerex G-93	3.5	4.0	4.5	5.0	5.5	6.0
		OEM Advanced 93	3.5	4.0	4.5	5.0	5.5	6.0
7 to 11% by volume	Arteco	Havoline Extended Life Corrosion Inhibitor XLI [EU 32765]	2.6	3.0	3.4	3.7	4.1	4.4
	Chevron Lubricants	Delo XLI Corrosion Inhibitor - Concentrate	2.6	3.0	3.4	3.7	4.1	4.4
	Nalco Water An Ecolab Company	Alfloc™ 3443	1.75	2.0	2.25	2.5	2.75	3.0
		Alfloc™ 3477	1.75	2.0	2.25	2.5	2.75	3.0
	PrixMax Australia Pty. Ltd.	PrixMax RCP	2.6	3.0	3.4	3.7	4.1	4.4
	Total	WT Supra	2.6	3.0	3.4	3.7	4.1	4.4

Permissible concentration range	Manufacturer	Product name / brand name % by vol.	Reading on hand refractometer ¹⁾ at 20 °C (= degrees Brix)					
			7	8	9	10	11	12
5 to 6% by volume	Detroit Diesel Corporation	Power Cool 3000	Please use test kit of manufacturer					
	Fleetguard	DCA-4L						
	Penray	Pencool 3000						
3 to 4% by volume	Detroit Diesel Corporation	Power Cool 2000	Please use test kit of manufacturer					
	ImproChem	Cool-C18						
	Nalco Water An Ecolab Company	Nalcool® 2000						
	Penray	Pencool 2000						

Table 20:

¹⁾ = Concentration determined by means of suitable hand refractometer

Calibrate the hand refractometer with clean water at coolant temperature. The coolant temperature should be 20 °C. Observe the specifications of the manufacturer.

Operational monitoring of admissible concentrations, ethylene glycol based antifreeze (MEG) / propylene glycol based antifreeze (MPG)

The concentration is determined using a suitable glycol refractometer and direct reading of the scale value in % by vol. Care must be taken to read off from the relevant scale when using handheld refractometers indicating both MEG and MPG scaling.

4.8 Limit values for coolants

pH value when using:			Method
- Emulsifiable corrosion inhibiting oil	Min. 7.5	Max. 9.5	ASTM D 1287, ISO 976
- Antifreeze	Min. 7.5	Max. 9.0	
- Coolant without antifreeze for engines containing light metal	Min. 7.5	Max. 9.0	
- Coolant without antifreeze for engines free of light metal	Min. 7.5	Max. 11.0	

Table 21:

Silicon content in silicon-containing coolants			Method
Silicon	Min. 25 mg/l		ICP

Table 22:

The coolant must be changed in case of non-compliance with the above specifications.

Note:

For a holistic appraisal of a coolant function, apart from the above-mentioned limit values the respective coolant-specific characteristic data and the fresh water quality used must be taken into consideration.

4.9 Storage capability of coolant concentrates

The storage capability specifications refer to coolant concentrates in original, hermetically sealed packing with storage temperatures up to max. 30 °C.

The instructions of the manufacturer must also be observed.

Coolant concentrate	Limit value	Brand name / Comments
Emulsifiable corrosion inhibitor oil	6 months	
Antifreeze	Approx. 3 years	Observe manufacturer's specifications
Coolant without antifreeze	1 year	Detroit Diesel Corp. Power Cool 3000 Penray Pencool 3000
	2 years	Arteco Freecor NBI Chevron Texcool A-200 Detroit Diesel Corp. Power Cool 2000 ImproChem Cool-C 18 Nalco Nalcool® 2000 Penray Pencool 2000 PrixMax RCP
	3 years	BASF Glyscorr G93 green Drew Marine Drewgard XTA Ginouves York 719 Rolls-Royce Solutions GmbH Coolant CS100 Rolls-Royce Solutions America inc. Power Cool® Plus 6000 Nalco Alfloc™ 3477 Valvoline ZEREX G-93 Valvoline OEM Advanced 93
	5 years	Arteco Havoline Extended Life Corrosion Inhibitor XLI [EU 032765] CCI Corporation A216 CCI Manufacturing IL A216 Chevron Delo XLI Corrosion Inhibitor Concentrate Detroit Diesel Corp. Power Cool Plus 6000 ExxonMobil Mobil Delvac Extended Life Corrosion Inhibitor Fleetguard DCA-4L Old World Industries Final Charge Extended Life Corrosion Inhibitor (A216) Total WT Supra

Table 23:

Note:

For reasons of corrosion protection, do not store in galvanized bins. Take this requirement into account when coolant must be transferred.

Containers must be hermetically sealed and stored in a cool, dry place. Frost protection must be provided in winter.

Further information can be obtained from the product and safety data sheets for the individual coolants.

4.10 Color additives to detect leakage in the coolant circuit

The fluorescent dye listed below is approved as an additive for coolant without antifreeze and antifreeze to detect leakages.

¹⁾ = Based on original and hermetically sealed containers in frost-free storage (> 5 °C)

Approved color additives

Manufacturer	Product name	Material no.	Container size	Storage stability ¹⁾
Chromatech Inc. Chromatech Europe B.V.	D11014 Chromatint Uranine Conc	X00066947	20 kg	2 years

Table 24:

Application:

Add approx. 40 g of dye per 180 l of coolant.

This is a generous amount of dye which is not to be exceeded.

Fluorescence (yellow hue) is clearly visible in daylight. UV light with a wavelength of 365 nm can be used in darker rooms.

5 Liquid Fuels

5.1 Diesel fuels – General information

Important

Dispose of used fluids and lubricants in accordance with local regulations.
Used oil must never be disposed of via the internal combustion engine!

Selection of a suitable diesel fuel

The quality of the fuel is very important for satisfactory engine performance, long engine service life and acceptable exhaust emission levels.

Important

Diesel fuels are not available worldwide in the required (→ Table 25) quality.
The fuel properties depend on many factors, in particular, region, time of year, and storage.

Important

If the fuel is to be stored in storage tanks for an extended period of time, we strongly recommend the use of B0 fuel (biodiesel / FAME-free fuel). FAME (Fatty Acid Methyl Ester) stands for first generation biodiesel. Rolls-Royce Solutions provides project-specific consultation on request.
We recommend to determine the oxidation stability (EN ISO 12205 / ASTM D 2274) to check the quality.

Unsuitable fuel usually leads to a reduced useful life of engine components and can also cause engine damage.

Further details on fuel qualities, tank care and filtration are available in the publication “Useful information on fuels, tank systems and filtration” (publication number A060631/..).

Fuel specifications to be complied with

		Test Method		Limit values
		ASTM		
Composition				The diesel fuel must be free of inorganic acids, visible water, solid foreign matter and chlorous compounds
Total contamination (= fuel-insoluble ingredients)	max.	D6217	EN 12662	24 mg/kg
Density at 15 °C	min.	D1298	EN ISO 3675	0.820 g/ml
	max.	D4052	EN ISO 12185	0.860 g/ml
API gravity at 60 °F	min.	D287		41
	max.			33
Viscosity at 40 °C	min.	D445	EN ISO 3104	1.5 mm ² /s
	max.			4.5 mm ² /s
Flashpoint (closed crucible)	greater	D93	DIN EN ISO 2719	55 °C (60 °C for SOLAS) ¹⁾

TIM-ID: 0000018622 - 008

		Test Method		Limit values
		ASTM		
Boiling curve:		D86	EN 17306	
- Initial boiling point				160 to 220 °C
- Volume share at 250 °C	max.			65% by volume
Recovery at 350 °C	min.			85% by volume
- Residue and loss	max.			3% by volume
Fatty acid methyl ester content (FAME) ("Biodiesel")	max.		EN 14078 Internal mtuprocedure	7.0% by volume
Proportion of water: (absolute, no free water)	max.	D6304	EN ISO 12937	200 mg/kg
- 12V4000U83 (CJC™ fine filter system is mandatory)	max.			70 mg/kg
Carbon residue from 10% distillation residue	max.	D189	EN ISO 10370	0.30% by weight
Oxide ash: ²⁾		D482	EN ISO 6245	
- Engines without exhaust gas aftertreatment and without exhaust gas recirculation	max.			0.01% by weight (100 mg/kg)
- Engines with exhaust gas aftertreatment or with exhaust gas recirculation	max.			0.001 % by weight (10 mg/kg)
Sulfur content: ²⁾		D5453 D2622	EN ISO 20846 EN ISO 20884	
- Engines without exhaust gas aftertreatment or without exhaust gas recirculation	max.			0.5% by weight (5000 mg/kg) ³⁾ (→ Page 40)
- Engines with exhaust gas aftertreatment or with exhaust gas recirculation	max.			0.0015% by weight (15 mg/kg) ³⁾
- Series 2000Bx6 / Gx6	max.			0.05% by weight (500 mg/kg) ³⁾
- Series 2000Cx6 / Sx6	max.			0.0015% by weight (15 mg/kg) ³⁾
- Series 2000Mx0 / Mx1 / Mx2 / Mx3 / Mx4 / Mx6 / Mx7	max.			0.05% by weight (500 mg/kg) ³⁾
- Series 4000Mx5 IMO II / IMO III	max.			0.1% by weight (1000 mg/kg) ³⁾
- 8V4000M63/20V4000M53B IMO III	max.			0.1% by weight (1000 mg/kg) ³⁾
- Series 4000M73-M93L IMO III	max.			0.1% by weight (1000 mg/kg) ³⁾
- Series 4000Mx5 EPA T4	max.			0.0015% by weight (15 mg/kg) ³⁾
- Series 4000R64 / R74 / R84 / T94 / T94L	max.			0.0015% by weight (15 mg/kg) ³⁾
Cetane number	min.	D613	EN ISO 5165 EN ISO 15195	45

		Test Method		Limit values
		ASTM		
Cetane index	min.	D976	EN ISO 4264	42
Copper corrosion 3 hrs. at 50 °C	Max. de- gree of cor- rosion	D130	EN ISO 2160	1 a
Oxidation stability (Rancimat)	min.		EN 15751	20 hours
Oxidation stability	max.	D2274	EN ISO 12205	25 g/m ³
Lubricity at 60 °C (HFRR value)	max.	D6079	EN ISO 12156-1	520 µm
Neutralization number	max.	D974		0.2 mgKOH/g

Table 25:

- 1) For marine applications, a min. flashpoint of 60 °C (SOLAS = Safety of life at sea) applies.
- 2) See series-specific injection / and exhaust gas aftertreatment systems (→ Page 44) for the definition as to whether an exhaust gas aftertreatment system is installed.
- 3) Note: 1 by weight % = 10000 mg/kg = 10000 ppm

Diesel fuels in winter operation

At low outdoor temperatures, the diesel fuel's fluidity can be inadequate on account of paraffin precipitation. It is the fuel supplier's responsibility to provide a fuel that will assure correct engine operation at the expected minimum temperatures and under the given geographical and other local conditions.

The operating company must ensure that there is always sufficient fuel to meet the corresponding climatic requirements.

In order to prevent operational problems (e.g. clogged filters) during the winter months, diesel fuel with suitable cold-flow characteristics is available on the market. Deviations are possible during transitional periods and in individual countries.

The following parameters define the cold-flow characteristics:

		Test Method		Limit values
		ASTM		
Filter plugging point (CFPP)		D6371	DIN EN 116	See Note ¹⁾
Cloud point		D2500	DIN EN 23015	See Note ²⁾

Table 26:

- 1) Filter plugging point or Cold Filter Plugging Point (CFPP) denotes the temperature at which a test filter is blocked under defined conditions by precipitated paraffins. This characteristic is used for diesel fuels as per DIN EN 590 to describe the climatic requirements (e.g. summer and winter diesel).
- 2) The cloud point is the temperature at which a liquid product becomes turbid in the test glass due to precipitation of paraffin. This must not be higher than the ambient temperature.

Use of fuels with higher sulfur content:

The engines are certified for operation with the fuels approved in these Fluids and Lubricants Specifications.

The component TBO specified in the maintenance schedule relates to operation of the engine with diesel fuel as per DIN EN 590.

For operation with a high sulfur content in the fuel, the following must be observed:

Series 4000

When a fuel with sulfur content > 3000 mg/kg is used, the times specified in the maintenance schedule for component TBO of the cylinder head may be reduced, see following table (→ Table 27)

TBO cylinder head as a function of sulfur content in the fuel

Sulfur content in fuel (mg/kg)	TBO cylinder head (h)
<3000	according to maintenance schedule
3000 - 4500	7000 ¹⁾
4500 - 5000	5000 ¹⁾

Table 27:

¹⁾= If the TBO for the cylinder head specified in the maintenance schedule is shorter, the shorter TBO shall always apply.

Engines with exhaust gas recirculation and/or exhaust aftertreatment system must not be operated with increased sulfur content in the fuel. The limit values in the Fluids and Lubricants Specifications apply.

Important

If the sulfur content in the fuel is > 0.5 % by weight (> 5000ppm), please consult with the Rolls-Royce Solutions GmbH (Application).

When engines are operated with diesel fuels with a sulfur content of more than 0.5 % by weight, appropriate engine oils must be used. The criteria for the selection of engine oils can be found in the chapter “Engine oils” (→ Page 7) under the notices regarding the use of diesel fuels with a higher sulfur content and Figure 2.

Note:

For safe and efficient engine operation, the limit values specified in (→ Table 25), in particular for water, total contamination, must be observed for all approved fuel grades at the interface marked in Fig. 3 item 6, for series 4000 U83 engines in Fig. 4 items 2 and 5 at the latest.

Important

In addition to the limit values named in (→ Table 25), a particle distribution in the fuel according to ISO 4406 must be observed:

Particle distribution	Test method ASTM		Limit values	
			Common rail	conventional injection
Particle distribution for fuel between last tank before engine and prefilter (see Fig. 3 item 5 and Fig. 4 item 2)	D7619 D7647	Coding of number of particles as per ISO 4406	max. ISO Code 18/17/14 for 4/6/14 µm particle size	max. ISO Code 21/20/17 for 4/6/14 µm particle size

Table 28:

Important

The limit values named in (→ Table 28) must already be observed in the feed between the last tank before the engine and the prefilter (if necessary, with water separator).

For plants without a prefilter, this refers to the feed between the last tank and the scope of supply of Rolls-Royce Solutions. For the analysis of the fuel quality, an interface (sample extraction cock) must be provided for sample extraction during operation.

For existing plants without an accessible feed, a sample extraction point in the last tank before the scope of supply of Rolls-Royce Solutions is permissible.

General fuel system diagram for diesel engines

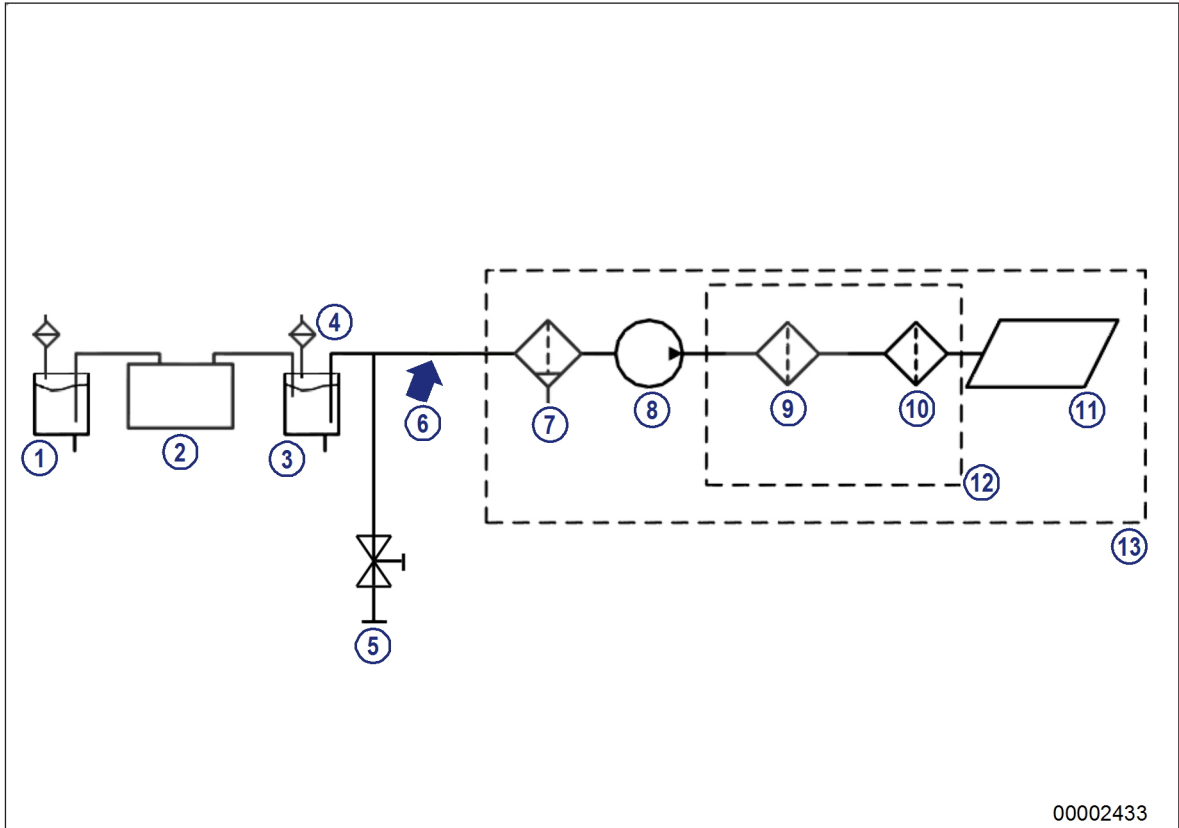
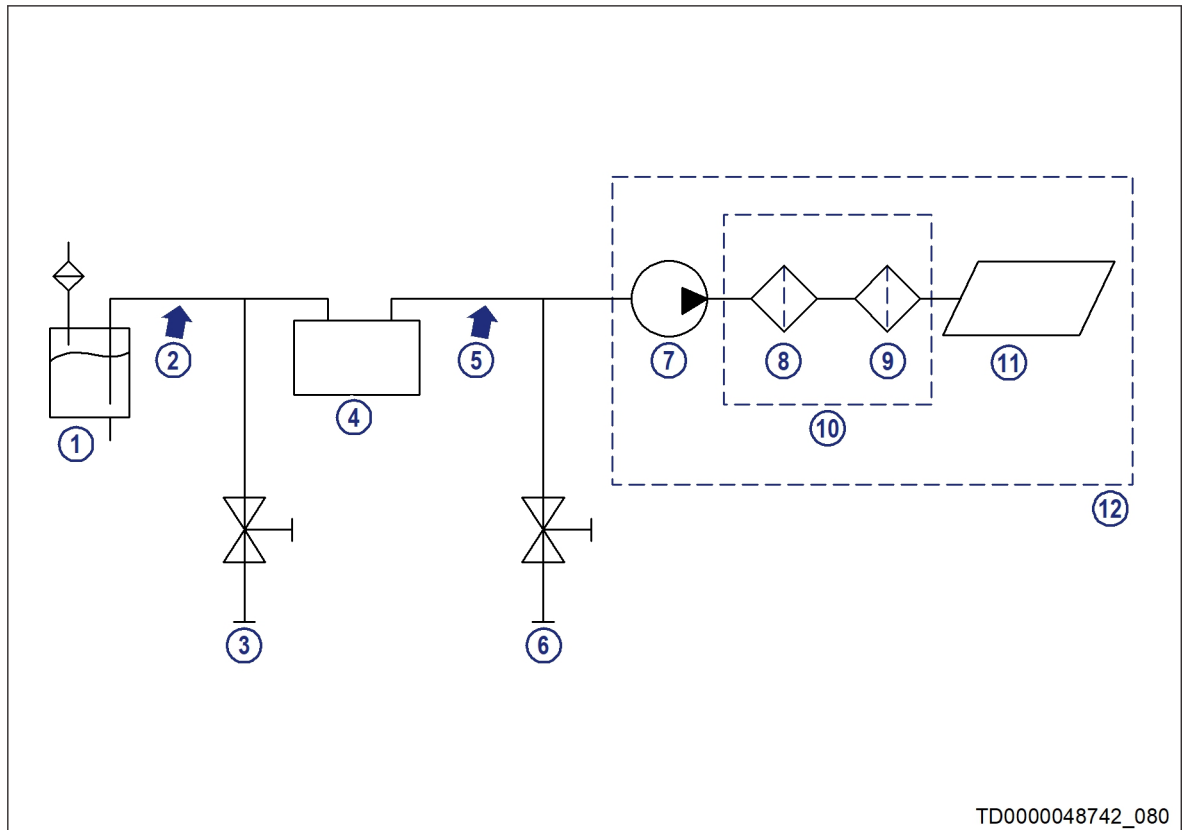

Figure 3:

- | | | |
|------------------------------|--|---------------------|
| 1 Fuel tank | 6 Interface for fuel specification | 11 Injection system |
| 2 Fuel conditioning (option) | 7 Fuel prefilter with water separator (option) | 12 Engine filter |
| 3 Last tank before engine | 8 LP fuel pump | 13 Engine scope |
| 4 Tank ventilation filter | 9 Intermediate filter (option) | |
| 5 Sample extraction | 10 Main filter | |

00002433

Fuel system diagram for Series 4000U83 diesel engines



TD0000048742_080

Figure 4:

- | | | |
|---|---|---------------------|
| 1 Fuel tank | 5 Interface for fuel specification after CJC™ fine filter system / before engine (max. 70ppm water content) | 9 Main filter |
| 2 Interface for fuel specification before CJC™ fine filter system (max. 200ppm water content) | 6 Sample extraction | 10 Engine filter |
| 3 Sample extraction | 7 LP fuel pump | 11 Injection system |
| 4 CJC™ fine filter system required | 8 Intermediate filter (option) | 12 Engine scope |

Note:

With poorer particle distribution, it is necessary to integrate further / more-optimized filter stages in the fuel system to achieve the operational life of fuel filters and components of the injection system.

It has been validated that prefilters approved by Rolls-Royce Solutions provide sufficient filtration for the limit values named for this interface.

For the submarine application (12V4000U83), a max. proportion of water of 70 mg/kg after the CJC™ fine filter system is permissible.

Damage and disadvantages to engines caused by the use fuel grades other than those approved by Rolls-Royce Solutions in accordance with (→ Table 25) and (→ Table 28) as well as chapter 5.2 (→ Page 45) or prefilter, are not deficiencies covered by the warranty of Rolls-Royce Solutions GmbH.

Series-related injection / and exhaust gas aftertreatment systems

Series	Diesel accumulator injection system (Common Rail)	Conventional injection systems	Exhaust aftertreatment system (EGAT)	Exhaust gas recirculation (EGR)
S60		yes	no	
099		yes	no	no
183		yes	no	no
396 C&I, Genset, Marine, Rail, Submarine		yes	no	no
538 Marine		yes	no	no
595 Marine		yes	no	no
956-01, -02, -03, -04		yes	no	no
1163-01, -02, -03		yes	no	no
1163-04	yes		no	no
2000Cx0, Cx1, Cx2, Gx3, Gx5, Mx0, Mx1, Px2, Sx0, Sx1, Sx2		yes	only Series 2000M4 1A IMO III	no
2000Cx6, Gx6, Mx2, Mx3, Mx4, Mx6, Mx7, Sx6	yes		Series 2000Mx7 only	only Series 2000Cx6 / Sx6
4000-00, -01, -02, -03, -04, -05	yes		only Series BR 4000R64 / R74 / R84 / Gx5 / Mx3 IMO III / Mx5 IMO III / Mx5 EPA T4	Series 4000Cx4 / Cx5 / Rx4 / T94 / T94L / T95 / T95L only
8000	yes		no	no
Two-stroke cycle engines		yes	no	no

Table 29:

Laboratory analysis

An order for fuel analysis can be placed with Rolls-Royce Solutions.

The following information is required:

- Fuel specifications
- Sampling point
- Serial number of engine from which fuel sample was taken

Submit the following:

- 1.0 liters of fuel
- 2.0 liters of fuel (with additional determination of cetane number)

5.2 Series-dependent approval of fuel grades for mtu engines

5.2.1 Distillate fuels as per DIN EN590 and ASTM D975

Commercially available diesel fuels meeting the following specifications are approved for use:

New series

Fuel specifications	DIN EN 590: 2017-10 Summer and winter quality	ASTM D975-19 Grade 1-D S 15, S 500, S 5000	ASTM D975-19 Grade 2-D S 15, S 500, S 5000
Restrictions	- SOLAS: Flashpoint min. 60 °C - Particle distribution for fuel in acc. with ta- ble 28 (→ Page 38)	- SOLAS: Flashpoint min. 60 °C - Density: 0.820 to 0.860 g/ml* * = deviating values: Approval possible project- specifically. If the density is too low, this can re- sult in a power reduction. In the framework of power readjustment, it is possible that the engine operational values change - Proportion of water: Max. 200 mg/kg - Total contamination: Max. 24 mg/kg - With exhaust gas aftertreatment: • Max. sulfur content of 15 mg/kg, or is defined series- and application-specifically - Particle distribution for fuel in acc. with table 28 (→ Page 38)	
Series			
S60	Approved	Approved	Approved
2000Cx0, Cx1, Cx2	Approved	Approved if:	Approved if:
2000Gx5, Gx6	Approved	- viscosity min. 1.5 mm ² /s	- cetane number min. 45 or
2000Mx0, Mx1, Mx2, Mx3, Mx4, Mx6, Mx7	Approved	- cetane number min. 45 or	- cetane index min. 42
2000Px2	Approved	- cetane index min. 42 - sulfur content max. 500 mg/kg	- sulfur content max. 500 mg/kg
2000M41A IMO III	Approved	Individual case approval	Individual case approval
2000Cx6	Approved	Approved if:	Approved if:
2000Sx6	Approved	- viscosity min. 1.5 mm ² /s	- cetane number min. 45 or
		- cetane number min. 45 or	- cetane index min. 42
		- cetane index min. 42 - sulfur content max. 15 mg/kg	- sulfur content max. 15 mg/kg

Fuel specifications	DIN EN 590: 2017-10 Summer and winter quality	ASTM D975-19 Grade 1-D S 15, S 500, S 5000	ASTM D975-19 Grade 2-D S 15, S 500, S 5000
Restrictions	- SOLAS: Flashpoint min. 60 °C - Particle distribution for fuel in acc. with ta- ble 28 (→ Page 38)	- SOLAS: Flashpoint min. 60 °C - Density: 0.820 to 0.860 g/ml* * = deviating values: Approval possible project- specifically. If the density is too low, this can re- sult in a power reduction. In the framework of power readjustment, it is possible that the engine operational values change - Proportion of water: Max. 200 mg/kg - Total contamination: Max. 24 mg/kg - With exhaust gas aftertreatment: • Max. sulfur content of 15 mg/kg, or is defined series- and application-specifically - Particle distribution for fuel in acc. with table 28 (→ Page 38)	
Series			
4000-00	Approved	Approved if:	Approved if:
4000-01	Approved	- viscosity min. 1.5 mm ² /s	- cetane number min. 45 or
4000-02	Approved	- cetane number min. 45	- cetane index min. 42
4000-03 C, G, P, R, S	Approved	or	
4000M23F, M23S	Approved	- cetane index min. 42	
4000M33F, M33S	Approved		
4000M53, M53R	Approved		
4000M63, M63L	Approved		
4000M53B, M73 - M93L, N43S, N83	Approved		
4000-04 G, M	Approved		
4000-05 G	Approved		
4000-05 M IMO II	Approved		
4000-05 M EPA T4	Not approved	Not approved	
4000-05 M IMO III	Approved	Approved if:	Approved if:
8V4000M63 IMO III	Approved	- viscosity min. 1.5 mm ² /s	- cetane number min. 45 or
20V4000M53B IMO III	Approved	- cetane number min. 45	- cetane index min. 42 - sulfur content max. 1000 mg/kg
		or	
		- cetane index min. 42	
		- sulfur content max. 1000 mg/kg	
12V4000U83	Approved if: - CJC™ fine filter system required • then max. proportion of water 70 mg/kg	Approved if: - viscosity min. 1.5 mm ² /s - cetane number min. 45 or - cetane index min. 42 - CJC™ fine filter system required • then max. proportion of water 70 mg/kg	Approved if: - cetane number min. 45 or - cetane index min. 42 - CJC™ fine filter system required • then max. proportion of water 70 mg/kg

Fuel specifications	DIN EN 590: 2017-10 Summer and winter quality	ASTM D975-19 Grade 1-D S 15, S 500, S 5000	ASTM D975-19 Grade 2-D S 15, S 500, S 5000
Restrictions	- SOLAS: Flashpoint min. 60 °C - Particle distribution for fuel in acc. with ta- ble 28 (→ Page 38)	- SOLAS: Flashpoint min. 60 °C - Density: 0.820 to 0.860 g/ml* * = deviating values: Approval possible project- specifically. If the density is too low, this can re- sult in a power reduction. In the framework of power readjustment, it is possible that the engine operational values change - Proportion of water: Max. 200 mg/kg - Total contamination: Max. 24 mg/kg - With exhaust gas aftertreatment: • Max. sulfur content of 15 mg/kg, or is defined series- and application-specifically - Particle distribution for fuel in acc. with table 28 (→ Page 38)	
Series			
4000C64	Approved	Approved if:	Approved if:
4000R54, R64, R74, R84	Approved	- viscosity min. 1.5 mm ² /s	- cetane number min. 45 or
4000T94, T94L	Approved	- cetane number min. 45	- cetane index min. 42
4000C45, C55, C65	Approved	or	- sulfur content max. 15 mg/kg
4000T95, T95L, T95R	Approved	- cetane index min. 42 - sulfur content max. 15 mg/kg	
8000	Approved	Approved if: - cetane number min. 45 or - cetane index min. 42 - sulfur content max. 50 mg/kg - viscosity min. 1.5 mm ² /s	Approved if: - cetane number min. 45 or - cetane index min. 42 - sulfur content max. 50 mg/kg

Table 30:

Classic series

Fuel specifications	DIN EN 590: 2017-10 Summer and winter quality	ASTM D975-19 Grade 1-D S 15, S 500, S 5000	ASTM D975-19 Grade 2-D S 15, S 500, S 5000
Restrictions	- SOLAS: Flashpoint min. 60 °C - Particle distribution for fuel in acc. with ta- ble 28 (→ Page 38)	- SOLAS: Flashpoint min. 60 °C - Density: 0.820 to 0.860 g/ml* * = deviating values: Approval possible project- specifically. If the density is too low, this can re- sult in a power reduction. In the framework of power readjustment, it is possible that the engine operational values change - Proportion of water: Max. 200 mg/kg - Total contamination: Max. 24 mg/kg - With exhaust gas aftertreatment: • Max. sulfur content of 15 mg/kg, or is defined series- and application-specifically - Particle distribution for fuel in acc. with table 28 (→ Page 38)	
Series			
099	Approved	Approved	Approved
183	Approved	Approved	Approved
396 C&I, Genset, Marine, Rail, Submarine	Approved	Approved if: - viscosity min. 1.5 mm ² /s - cetane number min. 45 or - cetane index min. 42	Approved if: - cetane number min. 45 or - cetane index min. 42
538 Marine 595 Marine	Approved Anti-wear additive neces- sary	Approved if: - viscosity min. 1.5 mm ² /s - cetane number min. 45 or - cetane index min. 42 Anti-wear additive neces- sary if sulfur content < 500 mg/kg	Approved if: - cetane number min. 45 or - cetane index min. 42 Anti-wear additive neces- sary if sulfur content < 500 mg/kg
956TB31, TB32, TB33 956TB34 Nuclear power station, emergency power*	Approved Anti-wear additive neces- sary	Approved - viscosity min. 1.5 mm ² /s - cetane number min. 45 or - cetane index min. 42 Anti-wear additive neces- sary if sulfur content < 500 mg/kg	Approved - cetane number min. 45 or - cetane index min. 42 Anti-wear additive neces- sary if sulfur content < 500 mg/kg
956-01 Marine / Rail 956-02 Marine	Approved Anti-wear additive neces- sary	Approved if: - viscosity min. 1.5 mm ² /s - cetane number min. 45 or - cetane index min. 42 Anti-wear additive neces- sary if sulfur content < 500 mg/kg	Approved if: - cetane number min. 45 or - cetane index min. 42 Anti-wear additive neces- sary if sulfur content < 500 mg/kg

Fuel specifications	DIN EN 590: 2017-10 Summer and winter quality	ASTM D975-19 Grade 1-D S 15, S 500, S 5000	ASTM D975-19 Grade 2-D S 15, S 500, S 5000
Restrictions	- SOLAS: Flashpoint min. 60 °C - Particle distribution for fuel in acc. with ta- ble 28 (→ Page 38)	- SOLAS: Flashpoint min. 60 °C - Density: 0.820 to 0.860 g/ml* * = deviating values: Approval possible project- specifically. If the density is too low, this can re- sult in a power reduction. In the framework of power readjustment, it is possible that the engine operational values change - Proportion of water: Max. 200 mg/kg - Total contamination: Max. 24 mg/kg - With exhaust gas aftertreatment: • Max. sulfur content of 15 mg/kg, or is defined series- and application-specifically - Particle distribution for fuel in acc. with table 28 (→ Page 38)	
Series			
1163TB32 Genset	Approved Anti-wear additive neces- sary	Approved - viscosity min. 1.5 mm ² /s - cetane number min. 45 or - cetane index min. 42 Anti-wear additive neces- sary if sulfur content < 500 mg/kg	Approved - cetane number min. 45 or - cetane index min. 42 Anti-wear additive neces- sary if sulfur content < 500 mg/kg
1163-02 Marine 1163-03 Marine	Approved Anti-wear additive neces- sary	Approved if: - viscosity min. 1.5 mm ² /s - cetane number min. 45 or - cetane index min. 42 Anti-wear additive neces- sary if sulfur content < 500 mg/kg	Approved if: - cetane number min. 45 or - cetane index min. 42 Anti-wear additive neces- sary if sulfur content < 500 mg/kg
1163-04 Marine	Approved	Approved if: - viscosity min. 1.5 mm ² /s - cetane number min. 45 or - cetane index min. 42	Approved if: - cetane number min. 45 or - cetane index min. 42

Table 31:

* = See “Selection of a suitable diesel fuel” (→ Page 38) under “If the fuel is to be stored in storage tanks for an extended period of time...”.

Two-stroke cycle engines

Fuel specifications	DIN EN 590: 2017-10 Summer and winter quality	ASTM D975-19 Grade 1-D S 15, S 500, S 5000	ASTM D975-19 Grade 2-D S 15, S 500, S 5000
Restrictions	- SOLAS: Flashpoint min. 60 °C - Particle distribution for fuel in acc. with table 28 (→ Page 38)	- SOLAS: Flashpoint min. 60 °C - Density: 0.820 to 0.860 g/ml* * = deviating values: Approval possible project-specifically. If the density is too low, this can result in a power reduction. In the framework of power readjustment, it is possible that the engine operational values change - Proportion of water: Max. 200 mg/kg - Total contamination: Max. 24 mg/kg - With exhaust gas aftertreatment: • Max. sulfur content of 15 mg/kg, or is defined series- and application-specifically - Particle distribution for fuel in acc. with table 28 (→ Page 38)	
Series			
S53, S71, S92, S149	Approved	Approved if: - lubricity max. 460 µm	Approved if: - lubricity max. 460 µm

Table 32:

5.2.2 British Standard

New series

Fuel specifications	BS 2869:2017 Part 1 Class A2	BS 2869:2017 Part 2 Class D		
Restrictions	<ul style="list-style-type: none"> - SOLAS: Flashpoint min. 60 °C - Density: max. 860 kg/m³ - Viscosity: max. 4.5 mm²/s. If viscosity min. 4.5 mm²/s: Preheating required - With exhaust gas aftertreatment: <ul style="list-style-type: none"> • Max. sulfur content of 15 mg/kg, or is defined series- and application-specifically - Particle distribution for fuel in acc. with table 28 (→ Page 38) 			
Series				
S60	Approved	Approved		
2000Cx0, Cx1, Cx2, Cx6	Not approved	Not approved		
2000Gx5, Gx6				
2000Mx0, Mx1, Mx2, Mx3, Mx4, Mx6, Mx7				
2000Px2				
2000Sx0, Sx1, Sx2, Sx6				
4000-00			Approved	Approved
4000-01				
4000-02				
4000-03 C, G, P, R, S				
4000M23F, M23S				
4000M33F, M33S				
4000M53, M53R				
4000M63, M63L				
4000M53B, M73 - 93L, N43S, N83				
4000-04 M				
12V4000U83	Approved if: - CJC™ fine filter system required • then max. proportion of water 70 mg/kg	Approved if: - CJC™ fine filter system required • then max. proportion of water 70 mg/kg		
4000-04 G	Approved	Approved		
4000C64	Approved if: - sulfur content max. 15 mg/kg	Approved if: - sulfur content max. 15 mg/kg		
4000R54, R64, R74, R84				
4000T94, T94L				
4000C45, C55, C65				
4000T95, T95L, T95R				

Fuel specifications	BS 2869:2017 Part 1 Class A2	BS 2869:2017 Part 2 Class D
Restrictions	<ul style="list-style-type: none"> - SOLAS: Flashpoint min. 60 °C - Density: max. 860 kg/m³ - Viscosity: max. 4.5 mm²/s. If viscosity min. 4.5 mm²/s: Preheating required - With exhaust gas aftertreatment: <ul style="list-style-type: none"> • Max. sulfur content of 15 mg/kg, or is defined series- and application-specifically - Particle distribution for fuel in acc. with table 28 (→ Page 38) 	
Series		
4000-05 G, M	Not approved	Not approved
8000	Approved	Approved if: - sulfur content max. 50 mg/kg

Table 33:

Classic series

Fuel specifications	BS 2869:2017 Part 1 Class A2	BS 2869:2017 Part 2 Class D
Restrictions	<ul style="list-style-type: none"> - SOLAS: Flashpoint min. 60 °C - Density: max. 860 kg/m³ - Viscosity: max. 4.5 mm²/s. If viscosity min. 4.5 mm²/s: Preheating required - With exhaust gas aftertreatment: <ul style="list-style-type: none"> • Max. sulfur content of 15 mg/kg, or is defined series- and application-specifically - Particle distribution for fuel in acc. with table 28 (→ Page 38) 	
Series		
099	Approved	Approved
183	Approved	Approved
396 C&I, Genset, Marine, Rail, Submarine	Approved	Approved
538 Marine	Approved	Approved if: - sulfur content min. 500 mg/kg
595 Marine	Anti-wear additive necessary	
956TB31, TB32, TB33 956TB34 Nuclear power station, emergency power*	Approved Anti-wear additive necessary	Approved if: - sulfur content min. 500 mg/kg
956-01 Marine / Rail		
956-02 Marine		
1163-02TB32 Genset	Not approved	Not approved
1163-02 Marine	Approved	Approved if: - sulfur content min. 500 mg/kg
1163-03 Marine	Anti-wear additive necessary	
1163-04 Marine	Approved	Approved

Table 34:

* = see “Selection of a suitable diesel fuel” (→ Page 38) under “If the fuel is to be stored in storage tanks for an extended period of time...”.

Two-stroke cycle engines

Fuel specifications	BS 2869:2017 Part 1 Class A2	BS 2869:2017 Part 2 Class D
Restrictions	<ul style="list-style-type: none"> - SOLAS: Flashpoint min. 60 °C - Density: max. 860 kg/m³ - Viscosity: max. 4.5 mm²/s. If viscosity min. 4.5 mm²/s: Preheating required - With exhaust gas aftertreatment: <ul style="list-style-type: none"> • Max. sulfur content of 15 mg/kg, or is defined series- and application-specifically - Particle distribution for fuel in acc. with table 28 (→ Page 38) 	
Series		
S53, S71, S92, S149	Approved if: - lubricity max. 460 µm	Approved if: - lubricity max. 460 µm

Table 35:

5.2.3 Chinese distillate fuels according to GB 19147-2016, GB 252-2015 and GB 17411-2016

New series

Fuel specifications	GB 19147-2016 Grade 0 # III: S max. 350 mg/kg IV: S max. 50 mg/kg V: S max. 10 mg/kg	GB 252-2015 Grade 0 #	GB 17411-2016 Grade DMX
Restrictions	- SOLAS: Flashpoint min. 60 °C - Density: 0.820 to 0.860 g/ml* * = deviating values: Approval possible project-specifically. If the density is too low, this can result in a power reduction. Engine operating values may change as a result of power adjustment. - Proportion of water: Max. 200 mg/kg - Total contamination: Max. 24 mg/kg - With exhaust gas aftertreatment: <ul style="list-style-type: none"> • Max. sulfur content of 15 mg/kg, or is defined series- and application-specifically - Particle distribution for fuel in acc. with table 28 (→ Page 38) - Neutralization number: Max 0.2 mgKOH/g - Viscosity: at 40 °C: 1.5 to 4.5 mm ² /s		
Series			
S60	Approved	Approved	Approved
2000Cx0, Cx1, Cx2		Approval upon request	Not approved
2000Gx5, Gx6			
2000Mx0, Mx1, Mx2, Mx3, Mx4, Mx6			Approved if: - sulfur content max. 500 mg/kg
2000Mx7			Not approved
2000M41A IMO III	Not approved	Not approved	Not approved
2000Px2		Approval upon request	
2000Sx0, Sx1, Sx2			
2000Cx6			
2000Sx6	Approved if: - sulfur content max. 15 mg/kg		

Fuel specifications	GB 19147-2016 Grade 0 # III: S max. 350 mg/kg IV: S max. 50 mg/kg V: S max. 10 mg/kg	GB 252-2015 Grade 0 #	GB 17411-2016 Grade DMX
Restrictions	<ul style="list-style-type: none"> - SOLAS: Flashpoint min. 60 °C - Density: 0.820 to 0.860 g/ml* * = deviating values: Approval possible project-specifically. If the density is too low, this can result in a power reduction. Engine operating values may change as a result of power adjustment. - Proportion of water: Max. 200 mg/kg - Total contamination: Max. 24 mg/kg - With exhaust gas aftertreatment: <ul style="list-style-type: none"> • Max. sulfur content of 15 mg/kg, or is defined series- and application-specifically - Particle distribution for fuel in acc. with table 28 (→ Page 38) - Neutralization number: Max 0.2 mgKOH/g - Viscosity: at 40 °C: 1.5 to 4.5 mm²/s 		
Series			
4000-00	Approved	Approved	Approved
4000-01			
4000-02			
4000-03 C, G, P, R, S			
4000M23F, M23S			
4000M33F, M33S			
4000M53, M53R			
4000M63, M63L			
4000M53B, M73 - 93L, N43S, N83			
4000-04 M			
4000-05 M IMO II			Not approved
4000-04 G			Not approved
4000-05 G	Not approved	Not approved	Not approved
4000-05 M IMO III / EPA T4			
8V4000M63 IMO III / EPA T4			
20V4000M53B IMO III	Approved	Approved	
12V4000U83	Approved if: - CJCTM fine filter system required • then max. proportion of water 70 mg/kg	Approved if: - CJCTM fine filter system required • then max. proportion of water 70 mg/kg	
4000C64	Approved if: - sulfur content max. 15 mg/kg	Approved if: - sulfur content max. 15 mg/kg	
4000R54, R64, R74, R84			
4000T94, T94L			

TIM-ID: 000.0007995 - 004

Fuel specifications	GB 19147-2016 Grade 0 # III: S max. 350 mg/kg IV: S max. 50 mg/kg V: S max. 10 mg/kg	GB 252-2015 Grade 0 #	GB 17411-2016 Grade DMX
Restrictions	<ul style="list-style-type: none"> - SOLAS: Flashpoint min. 60 °C - Density: 0.820 to 0.860 g/ml* * = deviating values: Approval possible project-specifically. If the density is too low, this can result in a power reduction. Engine operating values may change as a result of power adjustment. - Proportion of water: Max. 200 mg/kg - Total contamination: Max. 24 mg/kg - With exhaust gas aftertreatment: <ul style="list-style-type: none"> • Max. sulfur content of 15 mg/kg, or is defined series- and application-specifically - Particle distribution for fuel in acc. with table 28 (→ Page 38) - Neutralization number: Max 0.2 mgKOH/g - Viscosity: at 40 °C: 1.5 to 4.5 mm²/s 		
Series			
4000C45, C55, C65	Approved if: - sulfur content max. 15 mg/kg	Approved if: - sulfur content max. 15 mg/kg	Not approved
4000T95, T95L, T95R			
8000	Approved if: - sulfur content max. 50 mg/kg	Approved if: - sulfur content max. 50 mg/kg	Approved if: - Viscosity: >4.5 mm ² /s - Preheating required - sulfur content max. 50 mg/kg

Table 36:

Classic series

Fuel specifications	GB 19147-2016 Grade 0 # III: S max. 350 mg/kg IV: S max. 50 mg/kg V: S max. 10 mg/kg	GB 252-2015 Grade 0 #	GB 17411-2016 Grade DMX
Restrictions	<ul style="list-style-type: none"> - SOLAS: Flashpoint min. 60 °C - Density: 0.820 to 0.860 g/ml* * = deviating values: Approval possible project-specifically. If the density is too low, this can result in a power reduction. Engine operating values may change as a result of power adjustment. - Proportion of water: Max. 200 mg/kg - Total contamination: Max. 24 mg/kg - With exhaust gas aftertreatment: <ul style="list-style-type: none"> • Max. sulfur content of 15 mg/kg, or is defined series- and application-specifically - Particle distribution for fuel in acc. with table 28 (→ Page 38) - Neutralization number: Max 0.2 mgKOH/g - Viscosity: at 40 °C: 1.5 to 4.5 mm²/s Fatty acid methyl ester content (FAME) content “biodiesel” < 1.0% by volume 		
Series			
099	Approved	Approval upon request	Approved
183			Approved
396 C&I, Genset, Marine, Rail, Submarine		Approval upon request	Approved if: - sulfur content max. 0.5% (5000 mg/kg)
538 Marine	Approved Anti-wear additive necessary	Approval upon request	
595 Marine	Approved Anti-wear additive necessary	Approval upon request	
956TB31, TB32	Approved Anti-wear additive necessary	Approval upon request	Not approved
956TB33, TB34		Approved Anti-wear additive necessary	
Nuclear power station, emergency power			
956-01 Marine / Rail	Approved Anti-wear additive necessary	Approval upon request	Approved if: - sulfur content max. 0.5% (5000 mg/kg)
956-02 Marine	Approved Anti-wear additive necessary	Approval upon request	
1163-02TB32 Genset	Approved Anti-wear additive necessary	Approval upon request	Not approved

Fuel specifications	GB 19147-2016 Grade 0 # III: S max. 350 mg/kg IV: S max. 50 mg/kg V: S max. 10 mg/kg	GB 252-2015 Grade 0 #	GB 17411-2016 Grade DMX
Restrictions	<ul style="list-style-type: none"> - SOLAS: Flashpoint min. 60 °C - Density: 0.820 to 0.860 g/ml* * = deviating values: Approval possible project-specifically. If the density is too low, this can result in a power reduction. Engine operating values may change as a result of power adjustment. - Proportion of water: Max. 200 mg/kg - Total contamination: Max. 24 mg/kg - With exhaust gas aftertreatment: <ul style="list-style-type: none"> • Max. sulfur content of 15 mg/kg, or is defined series- and application-specifically - Particle distribution for fuel in acc. with table 28 (→ Page 38) - Neutralization number: Max 0.2 mgKOH/g - Viscosity: at 40 °C: 1.5 to 4.5 mm²/s Fatty acid methyl ester content (FAME) content “biodiesel” < 1.0% by volume 		
Series			
1163-02 Marine	Approved Anti-wear additive necessary	Approval upon request	Approved if: - sulfur content max. 0.5% (5000 mg/kg)
1163-03 Marine	Approved Anti-wear additive necessary	Approval upon request	
1163-04 Marine	Approved	Approval upon request	

Table 37:

Two-stroke cycle engines

Fuel specifications	GB 19147-2016 Grade 0 # III: S max. 350 mg/kg IV: S max. 50 mg/kg V: S max. 10 mg/kg	GB 252-2015 Grade 0 #	GB 17411-2016 Grade 0 # I: S max. 10000 mg/kg II: S max. 5000 mg/kg III: S max. 1000 mg/kg
Restrictions	- SOLAS: Flashpoint min. 60 °C - Density: 0.820 to 0.860 g/ml* * = deviating values: Approval possible project-specifically. If the density is too low, this can result in a power reduction. In the framework of power readjustment, it is possible that the engine operational values change. - Proportion of water: Max. 200 mg/kg - Total contamination: Max. 24 mg/kg - With exhaust gas aftertreatment: <ul style="list-style-type: none"> • Max. sulfur content of 15 mg/kg, or is defined series- and application-specifically - Particle distribution for fuel in acc. with table 28 (→ Page 38) - Neutralization number: Max 0.2 mgKOH/g - Viscosity: at 40 °C: 1.5 to 4.5 mm ² /s		- SOLAS: Flashpoint min. 60 °C - Density: 0.820 to 0.860 g/ml* * = deviating values: Approval possible project-specifically. If the density is too low, this can result in a power reduction. Engine operating values may change as a result of power adjustment. - Proportion of water: Max. 200 mg/kg - Total contamination: Max. 24 mg/kg - With exhaust gas aftertreatment: <ul style="list-style-type: none"> • Max. sulfur content of 15 mg/kg, or is defined series- and application-specifically - Particle distribution for fuel in acc. with table 28 (→ Page 38) - Neutralization number: Max 0.2 mgKOH/g - Viscosity: at 40 °C: 1.5 to 4.5 mm ² /s Fatty acid methyl ester content (FAME) content "biodiesel" < 1.0% by volume
Series	Approved	Approval upon request	Not approved
S53, S71, S92, S149	Approved	Approval upon request	Not approved

Table 38:

5.2.4 Heating oil

Commercially available diesel fuels meeting the following specifications are approved for use:

New series

Fuel specifications	DIN 51603-1:2020-09		DIN 51603-6:2017-03
	Heating oil EL standard	Heating oil EL low-sulfur	Heating oil EL alternative
Restrictions	- SOLAS: Flashpoint min. 60 °C - cetane number min. 45 or - cetane index min. 42 - lubricity max. 520 µm - With exhaust gas aftertreatment: <ul style="list-style-type: none"> • Max. sulfur content of 15 mg/kg, or is defined series- and application-specifically 		
Series			
S60	Approved	Approved	Not approved
2000Cx0, Cx1, Cx2	Approved if: - density at 15 °C min. 0.820g/ml - sulfur content max. 500 mg/kg	Approved	Not approved
2000Gx5			
2000Mx0, Mx1			
2000Px2			
2000Sx0, Sx1, Sx2			
2000M41A IMO III	Individual case approval	Approved	Not approved
2000Gx6	Approved if: - sulfur content max. 500 mg/kg	Approved	Not approved
2000Mx2, Mx3, Mx4, Mx6, Mx7			
2000Cx6	Not approved	Approved if: - sulfur content max. 15 mg/kg	Not approved
2000Sx6			
4000-00	Approved	Approved	Not approved
4000-01	Approved	Approved	Not approved
4000-02	Approved	Approved	Not approved
4000-03 C, G, P, R, S	Approved	Approved	Not approved
4000M23F, M23S	Approved	Approved	Not approved
4000M33F, M33S			
4000M53, M53R			

TIM-ID: 0000071307 - 006

Fuel specifications	DIN 51603-1:2020-09 Heating oil EL standard		DIN 51603-6:2017-03 Heating oil EL alternative
Restrictions	Heating oil EL low-sulfur - SOLAS: Flashpoint min. 60 °C - cetane number min. 45 or - cetane index min. 42 - lubricity max. 520 µm - With exhaust gas aftertreatment: • Max. sulfur content of 15 mg/kg, or is defined series- and application-specifically - Particle distribution for fuel in acc. with table 28 (→ Page 38)		
Series			
20V4000M53B IMO III	Approved	Approved if: - viscosity min. 1.5 mm ² /s - cetane number min. 45 or - cetane index min. 42 - sulfur content max. 1000 mg/kg	Not approved
4000M63, M63L	Approved	Approved	Not approved
8V4000M63 IMO III	Approved	Approved if: - viscosity min. 1.5 mm ² /s - cetane number min. 45 or - cetane index min. 42 - sulfur content max. 1000 mg/kg	Not approved
4000M53B, M73 - 93L, N43S, N83	Approved	Approved	Not approved
12V4000U83	Approved if: - CJC™ fine filter system required • then max. proportion of water 70 mg/kg	Approved if: - CJC™ fine filter system required • then max. proportion of water 70 mg/kg	Not approved
4000-04 G	Approved	Approved	Not approved
4000-04 M	Approved	Approved	Not approved
4000-05 G	Not approved	Not approved	Not approved
4000-05 M EPA T4	Not approved	Not approved	Not approved

TIM-ID: 0000071307 - 006

Fuel specifications	DIN 51603-1:2020-09		DIN 51603-6:2017-03
Restrictions	Heating oil EL standard	Heating oil EL low-sulfur	Heating oil EL alternative
	- SOLAS: Flashpoint min. 60 °C - cetane number min. 45 or - cetane index min. 42 - lubricity max. 520 µm - With exhaust gas aftertreatment: <ul style="list-style-type: none"> • Max. sulfur content of 15 mg/kg, or is defined series- and application-specifically - Particle distribution for fuel in acc. with table 28 (→ Page 38)		
Series			
4000-05 M IMO II, IMO III	Not approved	Approved if: - viscosity min. 1.5 mm ² /s - cetane number min. 45 or - cetane index min. 42 - sulfur content max. 1000 mg/kg	Not approved
4000C64	Not approved	Approved if: - sulfur content max. 15 mg/kg	Not approved
4000R54, R64, R74, R84			
4000T94, T94L			
4000C45, C55, C65			
4000T95, T95L, T95R			
8000	Approved	Approved	Not approved

Table 39:

Classic series

Fuel specifications	DIN 51603-1:2020-09		DIN 51603-6:2017-03
Restrictions	Heating oil EL standard	Heating oil EL low-sulfur	Heating oil EL alternative
	- SOLAS: Flashpoint min. 60 °C - cetane number min. 45 or - cetane index min. 42 - lubricity max. 520 µm - With exhaust gas aftertreatment: <ul style="list-style-type: none"> • Max. sulfur content of 15 mg/kg, or is defined series- and application-specifically - Particle distribution for fuel in acc. with table 28 (→ Page 38)		
Series			
099	Approved	Approved	Not approved
183	Approved	Approved	Not approved

Fuel specifications	DIN 51603-1:2020-09		DIN 51603-6:2017-03
Restrictions	Heating oil EL standard	Heating oil EL low-sulfur	Heating oil EL alternative
Series	- SOLAS: Flashpoint min. 60 °C - cetane number min. 45 or - cetane index min. 42 - lubricity max. 520 µm - With exhaust gas aftertreatment: <ul style="list-style-type: none"> • Max. sulfur content of 15 mg/kg, or is defined series- and application-specifically - Particle distribution for fuel in acc. with table 28 (→ Page 38)		
396 C&I, Genset, Marine, Rail, Submarine	Approved	Approved	Not approved
538 Marine	Approved	Approved	Not approved
595 Marine	Anti-wear additive necessary if sulfur content < 500 mg/kg	Anti-wear additive necessary	
956TB31, TB32, TB33 956TB34 Nuclear power station, emergency power	Approved if: Heating oils EL standard and low-sulfur according to DIN 51603-1 must only be used if all requirements in acc. with Heating oil EL (→ Page 100) have been met.		Not approved
956-01 Marine / Rail	Approved	Approved	Not approved
956-02 Marine	Anti-wear additive necessary if sulfur content < 500 mg/kg	Anti-wear additive necessary	
1163-02TB32 Genset	Approved if: Heating oils EL standard and low-sulfur according to DIN 51603-1 must only be used if all requirements in acc. with Heating oil EL (→ Page 100) have been met.		Not approved
1163-02 Marine	Approved	Approved	Not approved
1163-03 Marine	Anti-wear additive necessary if sulfur content < 500 mg/kg	Anti-wear additive necessary	
1163-04 Marine	Approved	Approved	Not approved

Table 40:

TIM-ID: 0000071307 - 006

Two-stroke cycle engines

Fuel specifications	DIN 51603-1:2020-09		DIN 51603-6:2017-03
Restrictions	Heating oil EL standard	Heating oil EL low-sulfur	Heating oil EL alternative
Series	<ul style="list-style-type: none"> - SOLAS: Flashpoint min. 60 °C - cetane number min. 45 or - cetane index min. 42 - lubricity max. 520 µm - With exhaust gas aftertreatment: <ul style="list-style-type: none"> • Max. sulfur content of 15 mg/kg, or is defined series- and application-specifically - Particle distribution for fuel in acc. with table 28 (→ Page 38) 		
S53, S71, S92, S149	Not approved	Not approved	Not approved

Table 41:

5.2.5 Marine distillate fuels according to ISO 8217:2018-10

Commercially available diesel fuels meeting the following specifications are approved for use:

New series

Fuel specifications	Marine distillate fuel in accordance with DIN ISO 8217:2018-10			
Restrictions	DMX	DMA	DMZ	DMB
	To comply with SOLAS the flash-point must be min. 60 °C - Proportion of water: 200 mg/kg - Total contamination: Max. 24 mg/kg With exhaust gas aftertreatment: <ul style="list-style-type: none"> • Max. sulfur content of 15 mg/kg, or is defined series- and application-specifically - Particle distribution for fuel in acc. with table 28 (→ Page 38)			
Series				
S60	Approved	Not approved	Not approved	Not approved
2000 Cx0, Cx1, Cx2, Cx6	Not approved	Not approved	Not approved	Not approved
2000Gx5, Gx6,				
2000Mx0, Mx1, Mx2, Mx3, Mx4, Mx6	Approved if: <ul style="list-style-type: none"> - sulfur content max. 500 mg/kg - density 0.820 to 0.860 g/ml¹⁾ - neutralization number: Max 0.2 mgKOH/g - viscosity at 40 °C: 1.5 to 4.5 mm²/s 			
2000Mx7	Not approved			
2000M41A IMO III	Not approved			
2000Px2				
2000Sx0, Sx1, Sx2, Sx6				
4000-00	Approved if: Viscosity > 4.5 mm ² /s: <ul style="list-style-type: none"> • Preheating required 	Approved if: - viscosity 1.5 to 4.5 mm ² /s Outside the limit range between 1.5 to 4.5 mm ² /s ² (40 °C), approval following consultation with Rolls-Royce Solutions is possible, e.g. through limitation of the temperature range or preheating - density 0.820 to 0.860 g/ml - cetane number min. 45 or - cetane index min. 42		Not approved
4000-01				
4000-02				
4000-03 C, G, P, R, S				

TIM-ID: 0000071308 - 006

Fuel specifications	Marine distillate fuel in accordance with DIN ISO 8217:2018-10			
Restrictions	DMX	DMA	DMZ	DMB
	To comply with SOLAS the flash-point must be min. 60 °C - Proportion of water: 200 mg/kg - Total contamination: Max. 24 mg/kg With exhaust gas aftertreatment: • Max. sulfur content of 15 mg/kg, or is defined series- and application-specifically - Particle distribution for fuel in acc. with table 28 (→ Page 38)			
Series				
4000M23F, M23S	Approved if: - viscosity > 4.5 mm ² /s: • Preheating required	Approved if: - viscosity 1.5 to 4.5 mm ² /s Outside the limit range between 1.5 to 4.5 mm/s ² (40 °C), approval following consultation with Rolls-Royce Solutions is possible, e.g. through limitation of the temperature range or preheating - suitable filter system is used Except for area of application of EPA Tier 2		Not approved
4000M33F, M33S				
4000M53, M53R				
20V4000M53B IMO III	Approved if: - viscosity > 4.5 mm ² /s: • Preheating required - sulfur content max. 1000 mg/kg	Approved if: - viscosity 1.5 to 4.5 mm ² /s Outside the limit range between 1.5 to 4.5 mm/s ² (40 °C), approval following consultation with Rolls-Royce Solutions is possible, e.g. through limitation of the temperature range or preheating - suitable filter system is used Except for area of application of EPA Tier 2		Not approved
4000M63, M63L	Approved if: - viscosity > 4.5 mm ² /s: • Preheating required	Approved if: - viscosity 1.5 to 4.5 mm ² /s Outside the limit range between 1.5 to 4.5 mm/s ² (40 °C), approval following consultation with Rolls-Royce Solutions is possible, e.g. through limitation of the temperature range or preheating - suitable filter system is used Except for area of application of EPA Tier 2 - sulfur content max. 1000 mg/kg		Not approved
8V4000M63 IMO III	Approved if: - viscosity > 4.5 mm ² /s: • Preheating required - sulfur content max. 1000 mg/kg	Approved if: - viscosity 1.5 to 4.5 mm ² /s Outside the limit range between 1.5 to 4.5 mm/s ² (40 °C), approval following consultation with Rolls-Royce Solutions is possible, e.g. through limitation of the temperature range or preheating - suitable filter system is used Except for area of application of EPA Tier 2		Not approved

TIM-ID: 0000071308 - 006

Fuel specifications	Marine distillate fuel in accordance with DIN ISO 8217:2018-10			
Restrictions	DMX	DMA	DMZ	DMB
	To comply with SOLAS the flash-point must be min. 60 °C - Proportion of water: 200 mg/kg - Total contamination: Max. 24 mg/kg With exhaust gas aftertreatment: <ul style="list-style-type: none"> • Max. sulfur content of 15 mg/kg, or is defined series- and application-specifically - Particle distribution for fuel in acc. with table 28 (→ Page 38)			
Series				
4000M53B, M73-M93L, N43S, N83	Approved if: - viscosity > 4.5 mm ² /s: <ul style="list-style-type: none"> • Preheating required 	Approved if: - viscosity 1.5 to 4.5 mm ² /s Outside the limit range between 1.5 to 4.5 mm ² /s (40 °C), approval following consultation with Rolls-Royce Solutions is possible, e.g. through limitation of the temperature range or preheating - suitable filter system is used - density 0.820 to 0.870 g/ml - cetane number min. 45 or - cetane index min. 42 Except for area of application of EPA Tier 2 - sulfur content max. 1000 mg/kg		Not approved
4000M73-M93L IMO III	Approved if: - viscosity > 4.5 mm ² /s: <ul style="list-style-type: none"> • Preheating required - sulfur content max. 1000 mg/kg	Approved if: - viscosity 1.5 to 4.5 mm ² /s Outside the limit range between 1.5 to 4.5 mm ² /s (40 °C), approval following consultation with Rolls-Royce Solutions is possible, e.g. through limitation of the temperature range or preheating - suitable filter system is used - density 0.820 to 0.870 g/ml - cetane number min. 45 or - cetane index min. 42 Except for area of application of EPA Tier 2 - sulfur content max. 1000 mg/kg		
12V4000U83	Approved if: - CJCTM fine filter system required <ul style="list-style-type: none"> • then max. proportion of water 70 mg/kg 	Approved if: - CJCTM fine filter system required <ul style="list-style-type: none"> • then max. proportion of water 70 mg/kg 		Approved if: - CJCTM fine filter system required <ul style="list-style-type: none"> • then max. proportion of water 70 mg/kg
4000-04 G, except G44F, G44LF, G94F, G94LF	Approved if: - viscosity > 4.5 mm ² /s: <ul style="list-style-type: none"> • Preheating required 	Approved if: - viscosity > 4.5 mm ² /s: <ul style="list-style-type: none"> • Preheating required 	Approved if: - viscosity > 4.5 mm ² /s: <ul style="list-style-type: none"> • Preheating required 	Not approved

TIM-ID: 0000071308 - 006

Fuel specifications	Marine distillate fuel in accordance with DIN ISO 8217:2018-10			
Restrictions	DMX	DMA	DMZ	DMB
	To comply with SOLAS the flash-point must be min. 60 °C - Proportion of water: 200 mg/kg - Total contamination: Max. 24 mg/kg With exhaust gas aftertreatment: <ul style="list-style-type: none"> • Max. sulfur content of 15 mg/kg, or is defined series- and application-specifically - Particle distribution for fuel in acc. with table 28 (→ Page 38)			
Series				
4000-04 G44F, G44LF, G94F, G94LF	Not approved	Not approved	Not approved	Not approved
4000-04 M	Approved if: - viscosity > 4.5 mm ² /s: • Preheating required	Not approved	Not approved	Not approved
4000-05 G	Not approved	Not approved	Not approved	Not approved
4000-05 M EPA T4	Not approved	Not approved	Not approved	Not approved
4000-05 M IMO II / IMO III	Approved if: - viscosity > 4.5 mm ² /s: • Preheating required - sulfur content max. 1000 mg/kg	Approved if: - viscosity 1.5 to 4.5 mm ² /s Outside the limit range between 1.5 to 4.5 mm/s ² (40 °C), approval following consultation with Rolls-Royce Solutions is possible, e.g. through limitation of the temperature range or preheating - suitable filter system is used - density 0.820 to 0.870 g/ml - cetane number min. 45 or - cetane index min. 42 Except for area of application of EPA Tier 2 - sulfur content max. 1000 mg/kg		Not approved

Fuel specifications	Marine distillate fuel in accordance with DIN ISO 8217:2018-10			
Restrictions	DMX	DMA	DMZ	DMB
	To comply with SOLAS the flash-point must be min. 60 °C - Proportion of water: 200 mg/kg - Total contamination: Max. 24 mg/kg With exhaust gas aftertreatment: <ul style="list-style-type: none"> • Max. sulfur content of 15 mg/kg, or is defined series- and application-specifically - Particle distribution for fuel in acc. with table 28 (→ Page 38)			
Series				
4000C64	Not approved	Not approved	Not approved	Not approved
4000R54, R64, R74, R84				
4000T94, T94L				
4000C45, C55, C65				
4000T95, T95L, T95R				
8000	Approved if: - viscosity > 4.5 mm ² /s: <ul style="list-style-type: none"> • Preheating required - sulfur content max. 50 mg/kg	Approved if: - viscosity 1.5 to 4.5 mm ² /s Outside the limit range between 1.5 to 4.5 mm/s ² (40 °C), approval following consultation with Rolls-Royce Solutions is possible, e.g. through limitation of the temperature range or preheating - density 0.820 to 0.870 g/ml - cetane number min. 45 or - cetane index min. 42		Not approved

Table 42:

¹⁾ = Deviating values: Project-specific approval possible. If the density is too low, this can result in a power reduction. Engine operating values may change as a result of power adjustment.

Classic series

Fuel specifications	Marine distillate fuel in accordance with DIN ISO 8217:2018-10			
Restrictions	DMX	DMA	DMZ	DMB
	To comply with SOLAS the flash-point must be min. 60 °C - Proportion of water: 200 mg/kg - Total contamination: Max. 24 mg/kg With exhaust gas aftertreatment: <ul style="list-style-type: none"> • Max. sulfur content of 15 mg/kg, or is defined series- and application-specifically - Particle distribution for fuel in acc. with table 28 (→ Page 38)			
Series				
099	Approved	Upon request	Upon request	Not approved
183	Approved	upon request	upon request	Not approved
396 C&I, Genset, Marine, Rail, Submarine	Approved if: - sulfur content max. 0.5% (5000 mg/kg)	Approved if: - viscosity at 40 °C: 1.5 to 4.5 mm ² /s Outside the limit range between 1.5 to 4.5 mm/s ² , approval following consultation with Rolls-Royce Solutions is possible, e.g. by limiting the temperature range or preheating - density 0.820 to 0.860 g/ml - cetane number min. 45 or - cetane index min. 42 - sulfur content max. 0.5%	upon request	Not approved
538 Marine	Approved if: - sulfur content max. 0.5% (5000 mg/kg)	Upon request	Upon request	Not approved
595 Marine	Approved if: - sulfur content max. 0.5% (5000 mg/kg)	Approved if: - viscosity 1.5 to 4.5 mm ² /s Outside the limit range between 1.5 to 4.5 mm/s ² (40 °C), approval following consultation with Rolls-Royce Solutions is possible, e.g. through limitation of the temperature range or preheating - density 0.820 to 0.860 g/ml - cetane number min. 45 or - cetane index min. 42 - sulfur content max. 0.5%		Not approved

Fuel specifications	Marine distillate fuel in accordance with DIN ISO 8217:2018-10			
Restrictions	DMX	DMA	DMZ	DMB
Series	To comply with SOLAS the flash-point must be min. 60 °C - Proportion of water: 200 mg/kg - Total contamination: Max. 24 mg/kg With exhaust gas aftertreatment: <ul style="list-style-type: none"> • Max. sulfur content of 15 mg/kg, or is defined series- and application-specifically - Particle distribution for fuel in acc. with table 28 (→ Page 38)			
956TB31, TB32, TB33 956TB34 Nuclear power station, emergency power	Not approved	Not approved	Not approved	Not approved
956-01 Marine / Rail 956-02 Marine	Approved if: - sulfur content max. 0.5% (5000 mg/kg)	Approved if: - viscosity 1.5 to 4.5 mm ² /s Outside the limit range between 1.5 to 4.5 mm ² /s (40 °C), approval following consultation with Rolls-Royce Solutions is possible, e.g. through limitation of the temperature range or preheating - density 0.820 to 0.860 g/ml - cetane number min. 45 or - cetane index min. 42 - sulfur content max. 0.5%		Not approved
1163-02 TB32 Gen-set	Not approved	Not approved	Not approved	Not approved

Fuel specifications	Marine distillate fuel in accordance with DIN ISO 8217:2018-10			
Restrictions	DMX	DMA	DMZ	DMB
	To comply with SOLAS the flash-point must be min. 60 °C - Proportion of water: 200 mg/kg - Total contamination: Max. 24 mg/kg With exhaust gas aftertreatment: <ul style="list-style-type: none"> Max. sulfur content of 15 mg/kg, or is defined series- and application-specifically - Particle distribution for fuel in acc. with table 28 (→ Page 38)			
Series				
1163-02 Marine	Approved if: - sulfur content max. 0.5% (5000 mg/kg)	Approved if: - viscosity 1.5 to 4.5 mm ² /s Outside the limit range between 1.5 to 4.5 mm/s ² (40 °C), approval following consultation with Rolls-Royce Solutions is possible, e.g. through limitation of the temperature range or preheating - density 0.820 to 0.860 g/ml - cetane number min. 45 or - cetane index min. 42 - sulfur content max. 0.5%		Not approved
1163-03 Marine				
1163-04 Marine	Approved if: - sulfur content max. 0.5% (5000 mg/kg)	Approved if: - viscosity 1.5 to 4.5 mm ² /s Outside the limit range between 1.5 to 4.5 mm/s ² (40 °C), approval following consultation with Rolls-Royce Solutions is possible, e.g. through limitation of the temperature range or preheating - density 0.820 to 0.860 g/ml - cetane number min. 45 or - cetane index min. 42 - suitable filter system is used - sulfur content max. 0.5%		Not approved

Table 43:

Two-stroke cycle engines

Fuel specifications	Marine distillate fuel in accordance with DIN ISO 8217:2018-10			
Series	DMX	DMA	DMZ	DMB
S53, S71, S92, S149	Not approved	Not approved	Not approved	Not approved

Table 44:

5.2.6 Aviation turbine fuel

Commercially available diesel fuels meeting the following specifications are approved for use:

Aviation turbine fuel

New series

Fuel specifications Restrictions Series	F-34 / F-35 JP-8	F-44 JP-5	F-63 in accordance with DCSEA 108/A
S60	Not approved		
2000Cx0, Cx1, Cx2, Cx6	Not approved		
2000Gx5, Gx6	Not approved		
2000Mx0, Mx1, Mx2, Mx3, Mx4, Mx6, Mx7	Not approved		
2000Px2	Not approved		
2000Sx0, Sx1, Sx2, Sx6	Not approved		
4000-01	Not approved		Generally not approved, approval upon request
4000-02	Not approved		Generally not approved, approval upon request
4000-03 C, G, P, R, S	Not approved		Approved for: 4000-03 G
4000M23F, M23S	Not approved	F44 AVCAT: Operation for max. 12 h, then operation with other approved fuels for min. 12 h required ¹ .	Generally not approved, approval upon request
4000M33F, M33S	Not approved		Generally not approved, approval upon request
4000M53, M53R	Not approved		Generally not approved, approval upon request
4000M63, M63L	Not approved		Generally not approved, approval upon request
4000M53B, M73 - M93L	Not approved		Generally not approved, approval upon request
12V4000U83	Approved if: - CJC™ fine filter system required • then max. proportion of water 70 mg/kg	Generally not approved, approval upon request	Approved if: - CJC™ fine filter system required • then max. proportion of water 70 mg/kg
4000-04 G, except G44F, G44LF, G94F, G94LF	Not approved		Approved

Fuel specifications	F-34 / F-35 JP-8	F-44 JP-5	F-63 in accordance with DCSEA 108/A
Restrictions Series			
4000-04 G44F, G44LF, G94F, G94LF	Not approved		Generally not approved, approval upon request
4000-04 M	Not approved		Generally not approved, approval upon request
4000-05 G	Not approved		Generally not approved, approval upon request
4000-05 M	Not approved		Generally not approved, approval upon request
4000C64	Not approved		Generally not approved, approval upon request
4000R54, R64, R74, R84	Not approved		Generally not approved, approval upon request
4000T94, T94L	Not approved		Generally not approved, approval upon request
4000C45, C55, C65	Not approved		Generally not approved, approval upon request
4000T95, T95L, T95R	Not approved		Generally not approved, approval upon request
8000	Not approved		

Table 45:

¹⁾ = Maximum accumulated runtime for the complete injection system with F44: 1500 operating hours

Classic series

Fuel specifications	F-34 / F-35 JP-8	F-44 JP-5	F-63 in accordance with DCSEA 108/A
Restrictions Series			
099	Generally not approved, approval upon request		
183	Generally not approved, approval upon request		
396 C&I, Genset, Marine, Rail, Submarine	Generally not approved, approval upon request		
538 Marine	Generally not approved, approval upon request		
595 Marine			

TIM-ID: 0000071309 - 005

Fuel specifications	F-34 / F-35 JP-8	F-44 JP-5	F-63 in accordance with DCSEA 108/A
Restrictions			
Series			
956TB31, TB32, TB33 956TB34 Nuclear power station, emergency power	Generally not approved		
956-01 Marine / Rail	Generally not approved, approval upon request		
956-02 Marine			
1163-02 TB32 Genset	Generally not approved		
1163-02 Marine	Generally not approved, approval upon request	Approved	
1163-03 Marine			
1163-04 Marine	Generally not approved, approval upon request	Approved	

Table 46:

Two-stroke cycle engines

Fuel specifications	F-34 / F-35 JP-8	F-44 JP-5	F-63 in accordance with DCSEA 108/A
Series			
S53, S71, S92, S149	Generally not approved		

Table 47:

5.2.7 NATO diesel fuels

Commercially available diesel fuels meeting the following specifications are approved for use:

Diesel fuel NATO Code F-54

New series

Fuel specifications	NATO Code F-54 in accordance with TL 9140-0001 Edition 8	NATO Code F-54 in accordance with STANAG 7090 Edition 4
Restrictions	Approval if fuel corresponds to diesel fuel DIN EN 590:2014-04 - Total contamination: Max. 24 mg/kg - Lubricity: Max. 520 µm Furthermore: - SOLAS: Flashpoint min. 60 °C - With exhaust gas aftertreatment: • Max. sulfur content of 15 mg/kg, or is defined series- and application-specifically - Particle distribution for fuel in acc. with table 28 (→ Page 38)	Approval if fuel corresponds to diesel fuel DIN EN 590:2014-04 - Density: Min. 0.820 g/ml - Total contamination: Max. 24 mg/kg - Lubricity: Max. 520 µm Furthermore: - SOLAS: Flashpoint min. 60 °C - With exhaust gas aftertreatment: • Max. sulfur content of 15 mg/kg, or is defined series- and application-specifically - Particle distribution for fuel in acc. with table 28 (→ Page 38)
Series		
S60	Approved	Approved
2000Cx0, Cx1, Cx2	Approved if: - sulfur content max. 500 mg/kg	Approved if: - sulfur content max. 500 mg/kg
2000Gx5, Gx6		
2000Mx0, Mx1, Mx2, Mx3, Mx4, Mx6, Mx7		
2000Px2		
2000Sx0, Sx1, Sx2		
2000M41A IMO III	Individual case approval	Individual case approval
2000Cx6	Approved if: - sulfur content max. 15 mg/kg	Approved if: - sulfur content max. 15 mg/kg
2000Sx6		
4000-00	Approved	Approved
4000-01		
4000-02		
4000-03 C, G, P, R, S		
4000M23F, M23S	Approved	Approved
4000M33F, M33S		
4000M53, M53R		
4000M63, M63L		
4000M53B, M73 - 93L, N43S, N83	Approved	Approved

Fuel specifications	NATO Code F-54 in accordance with TL 9140-0001 Edition 8	NATO Code F-54 in accordance with STANAG 7090 Edition 4
Restrictions	Approval if fuel corresponds to diesel fuel DIN EN 590:2014-04 - Total contamination: Max. 24 mg/kg - Lubricity: Max. 520 µm Furthermore: - SOLAS: Flashpoint min. 60 °C - With exhaust gas aftertreatment: • Max. sulfur content of 15 mg/kg, or is defined series- and application-specifically - Particle distribution for fuel in acc. with table 28 (→ Page 38)	Approval if fuel corresponds to diesel fuel DIN EN 590:2014-04 - Density: Min. 0.820 g/ml - Total contamination: Max. 24 mg/kg - Lubricity: Max. 520 µm Furthermore: - SOLAS: Flashpoint min. 60 °C - With exhaust gas aftertreatment: • Max. sulfur content of 15 mg/kg, or is defined series- and application-specifically - Particle distribution for fuel in acc. with table 28 (→ Page 38)
Series		
12V4000U83	Approved if: - CJC™ fine filter system required • then max. proportion of water 70 mg/kg	Approved if: - CJC™ fine filter system required • then max. proportion of water 70 mg/kg
4000-04 G, except G44F,G44LF, G94F, G94LF	Approved	Approved
4000-04 G44F, G44LF, G94F, G94LF	Not approved	Not approved
4000-04 M	Approved	Approved
4000-05 G	Not approved	Not approved
4000-05 M	Not approved	Not approved
4000C64	Approved if: - sulfur content max. 15 mg/kg	Approved if: - sulfur content max. 15 mg/kg
4000R54, R64, R74, R84		
4000T94, T94L		
4000C45, C55, C65		
4000T95, T95L, T95R		
8000	Approved if: - sulfur content max. 50 mg/kg	Approved

Table 48:

Diesel fuel NATO Code F-75

New series

Fuel specifications	NATO Code F 75 TL 9140-0003	NATO Code F 75 STANAG 1385
Comments	- Reduced power possible due to min. density of 0.815 g/ml	- Possible power reduction and increase due to density range of 0.815 to 0.880 g/ml - max. sulfur content 1.0% → Adapt oil and oil change interval
Restrictions	- With exhaust gas aftertreatment: • Max. sulfur content of 15 mg/kg, or is defined series- and application-specifically - Particle distribution for fuel in acc. with table 28 (→ Page 38)	- Proportion of water: Max. 200 mg/kg - Total contamination: Max. 24 mg/kg With exhaust gas aftertreatment: • Max. sulfur content of 15 mg/kg, or is defined series- and application-specifically - Particle distribution for fuel in acc. with table 28 (→ Page 38)
Series		
S60	Not approved	Not approved
2000Cx0, Cx1, Cx2, Cx6	Not approved	Not approved
2000Gx5, Gx6		
2000Mx0, Mx1, Mx2, Mx3, Mx4, Mx6, Mx7		
2000Px2		
2000Sx0, Sx1, Sx2, Sx6		
4000-00	Approved	Approved if: - cetane number min. 45 or - cetane index min. 42
4000-01		
4000-02		
4000-03 C, G, P, R, S		
4000M23F, M23S	Approved	Approved
4000M33F, M33S		
4000M53, M53R		
4000M63, M63L		
4000M53B, M73 - 93L, N43S, N83	Approved	Approved if: - cetane number min. 45 or - cetane index min. 42
12V4000U83	Approved if: - CJC™ fine filter system required • then max. proportion of water 70 mg/kg	Approved if: - CJC™ fine filter system required • then max. proportion of water 70 mg/kg
4000-04 G, except G44F, G44LF, G94F, G94LF	Approved	Approved if: - cetane number min. 45 or - cetane index min. 42

Fuel specifications	NATO Code F 75 TL 9140-0003	NATO Code F 75 STANAG 1385
Comments	- Reduced power possible due to min. density of 0.815 g/ml	- Possible power reduction and increase due to density range of 0.815 to 0.880 g/ml - max. sulfur content 1.0% → Adapt oil and oil change interval
Restrictions	- With exhaust gas aftertreatment: • Max. sulfur content of 15 mg/kg, or is defined series- and application-specifically - Particle distribution for fuel in acc. with table 28 (→ Page 38)	- Proportion of water: Max. 200 mg/kg - Total contamination: Max. 24 mg/kg With exhaust gas aftertreatment: • Max. sulfur content of 15 mg/kg, or is defined series- and application-specifically - Particle distribution for fuel in acc. with table 28 (→ Page 38)
Series		
4000-04 G44F, G44LF, G94F, G94LF	Not approved	Not approved
4000-04 M	Approved	Approved if: - cetane number min. 45 or - cetane index min. 42
4000-05 G	Not approved	Not approved
4000-05 M	Not approved	Not approved
4000C64	Not approved	Not approved
4000R54, R64, R74, R84		
4000T94, T94L		
4000C45, C55, C65		
4000T95, T95L, T95R		
8000	Approved if: - sulfur content max. 50 mg/kg	Approved if: - density 0.820 to 0.860 g/ml - cetane number min. 45 or - cetane index min. 42 - sulfur content max. 50 mg/kg

Table 49:

Diesel fuel NATO Code F-76

New series

Fuel specifications	NATO Code F 76 STANAG 1385 Edition 6	NATO Code F 76 DEF-STAN 91-4 Edition 8	NATO Code F 76 MIL-DTL-16884N
Restrictions	- Proportion of water: Max. 200 mg/kg - Total contamination: Max. 24 mg/kg - With exhaust gas aftertreatment: <ul style="list-style-type: none"> • Max. sulfur content of 15 mg/kg, or is defined series- and application-specifically - Particle distribution for fuel in acc. with table 28 (→ Page 38)		
Series			
S60	Approved	Approved if: - density 0.820 to 0.860 g/ml	Approved
2000Cx0, Cx1, Cx2, Cx6	Generally not approved, approval upon request	Generally not approved, approval upon request	Generally not approved, approval upon request
2000Gx5, Gx6			
2000Mx0, Mx1, Mx2, Mx3, Mx4, Mx6, Mx7			
2000Px2			
2000Sx0, Sx1, Sx2, Sx6			
4000-00	Approved if: - cetane number min. 45 or - cetane index min. 42	Approved	Approved if: - cetane number min. 45 or - cetane index min. 42
4000-01			
4000-02			
4000-03 C, G, P, R, S			
4000M23F, M23S	Approved	Approved	Approved
4000M33F, M33S			
4000M53, M53R			
4000M63, M63L			
4000M53B, M73 - M93L, N43S, N83	Approved if: - cetane number min. 45 or - cetane index min. 42	Approved	Approved if: - cetane number min. 45 or - cetane index min. 42
12V4000U83	- CJC™ fine filter system required • then max. proportion of water 70 mg/kg	- CJC™ fine filter system required • then max. proportion of water 70 mg/kg	- CJC™ fine filter system required • then max. proportion of water 70 mg/kg
4000-04 G, except G44F, G44LF, G94F, G94LF	Approved if: - cetane number min. 45 or - cetane index min. 42	Approved	Approved if: - cetane number min. 45 or - cetane index min. 42
4000-04 G44F, G44LF, G94F, G94LF	Not approved	Not approved	Not approved

Fuel specifications	NATO Code F 76 STANAG 1385 Edition 6	NATO Code F 76 DEF-STAN 91-4 Edition 8	NATO Code F 76 MIL-DTL-16884N
Restrictions	- Proportion of water: Max. 200 mg/kg - Total contamination: Max. 24 mg/kg - With exhaust gas aftertreatment: <ul style="list-style-type: none"> Max. sulfur content of 15 mg/kg, or is defined series- and application-specifically - Particle distribution for fuel in acc. with table 28 (→ Page 38)		
Series			
4000-04 M	Approved if: - cetane number min. 45 or - cetane index min. 42	Approved	Approved if: - cetane number min. 45 or - cetane index min. 42
4000-05 G	Not approved	Not approved	Not approved
4000-05 M	Not approved	Not approved	Not approved
4000C64	Not approved	Not approved	Not approved
4000R54, R64, R74, R84			
4000T94, T94L			
4000C45, C55, C65			
4000T95, T95L, T95R			
8000	Approved if: - density 0.820 to 0.870 g/ml - cetane number min. 45 or - cetane index min. 42 - sulfur content max. 50 mg/kg	Approved if: - density 0.820 to 0.870 g/ml - cetane number min. 45 or - cetane index min. 42 - sulfur content max. 50 mg/kg	Approved if: - density 0.820 to 0.870 g/ml - cetane number min. 45 or - cetane index min. 42 - sulfur content max. 50 mg/kg

Table 50:

NATO diesel fuels

Diesel fuels Nato Code F-54

Classic series

Fuel specifications	NATO Code F-54 in accordance with TL 9140-0001 Edition 8	NATO Code F-54 in accordance with STANAG 7090 Edition 4
Restrictions	Approval if fuel corresponds to diesel fuel DIN EN 590:2014-04 - Total contamination: Max. 24 mg/kg - Lubricity: Max. 520 µm Furthermore: - SOLAS: Flashpoint min. 60 °C - With exhaust gas aftertreatment: • Max. sulfur content of 15 mg/kg, or is defined series- and application-specifically - Particle distribution for fuel in acc. with table 28 (→ Page 38)	Approval if fuel corresponds to diesel fuel DIN EN 590:2014-04 - Density: Min. 0.820 g/ml - Total contamination: Max. 24 mg/kg - Lubricity: Max. 520 µm Furthermore: - SOLAS: Flashpoint min. 60 °C - With exhaust gas aftertreatment: • Max. sulfur content of 15 mg/kg, or is defined series- and application-specifically - Particle distribution for fuel in acc. with table 28 (→ Page 38)
Series		
099	Approved	Approved
183	Approved	Approved
396 C&I, Genset, Marine, Rail, Submarine	Approved	Approved
538 Marine	Approved	Approved
595 Marine	Anti-wear additive necessary if sulfur content < 500 mg/kg	Anti-wear additive necessary
956TB 31, TB32, TB33 956TB34 Nuclear power station, emergency power	Approved Anti-wear additive necessary if sulfur content < 500 mg/kg	Approved Anti-wear additive necessary
956-01 Marine / Rail	Approved	Approved
956-02 Marine	Anti-wear additive necessary if sulfur content < 500 mg/kg	Anti-wear additive necessary
1163-02TB32 Genset	Approved Anti-wear additive necessary if sulfur content < 500 mg/kg	Approved Anti-wear additive necessary
1163-02 Marine	Approved	Approved
1163-03 Marine	Anti-wear additive necessary if sulfur content < 500 mg/kg	Anti-wear additive necessary
1163-04 Marine	Approved	Approved

Table 51:

Diesel fuel NATO Code F-75

Classic series

Fuel specifications	NATO Code F 75 TL 9140-0003	NATO Code F 75 STANAG 1385
Comments	- Reduced power possible due to min. density of 0.815 g/ml	- Possible power reduction and increase due to density range of 0.815 to 0.880 g/ml - max. sulfur content 1.0% → Adapt oil and oil change interval
Restrictions	- With exhaust gas aftertreatment: • Max. sulfur content of 15 mg/kg, or is defined series- and application-specifically - Particle distribution for fuel in acc. with table 28 (→ Page 38)	- Proportion of water: Max. 200 mg/kg - Total contamination: Max. 24 mg/kg With exhaust gas aftertreatment: • Max. sulfur content of 15 mg/kg, or is defined series- and application-specifically - Particle distribution for fuel in acc. with table 28 (→ Page 38)
Series		
099	Approved	upon request
183	Approved	upon request
396 C&I, Genset, Marine, Rail, Submarine	Approved	upon request
538 Marine	Approved	upon request
595 Marine	Approved	Approved if: - density 0.820 to 0.860 g/ml - cetane number min. 45 or - cetane index min. 42 - sulfur content max. 0.5% and min. 0.05%
956TB31, TB32, TB33 956TB34 Nuclear power station, emergency power	Not approved	Not approved
956-01 Marine / Rail 956-02 Marine	Approved	Approved if: - density 0.820 to 0.860 g/ml - cetane number min. 45 or - cetane index min. 42 - sulfur content max. 0.5% and min. 0.05%
1163-02 TB32 Genset	Not approved	Not approved

Fuel specifications	NATO Code F 75 TL 9140-0003	NATO Code F 75 STANAG 1385
Comments	- Reduced power possible due to min. density of 0.815 g/ml	- Possible power reduction and increase due to density range of 0.815 to 0.880 g/ml - max. sulfur content 1.0% → Adapt oil and oil change interval
Restrictions	- With exhaust gas aftertreatment: • Max. sulfur content of 15 mg/kg, or is defined series- and application-specifically - Particle distribution for fuel in acc. with table 28 (→ Page 38)	- Proportion of water: Max. 200 mg/kg - Total contamination: Max. 24 mg/kg With exhaust gas aftertreatment: • Max. sulfur content of 15 mg/kg, or is defined series- and application-specifically - Particle distribution for fuel in acc. with table 28 (→ Page 38)
Series		
1163-02 Marine	Approved	Approved if: - density 0.820 to 0.860 g/ml - cetane number min. 45 or - cetane index min. 42 - sulfur content max. 0.5% and min. 0.05%
1163-03 Marine		
1163-04 Marine	Approved	Approved if: - density 0.820 to 0.860 g/ml - cetane number min. 45 or - cetane index min. 42 - sulfur content max. 0.5%

Table 52:

Diesel fuel NATO Code F-76

Classic series

Fuel specifications	NATO Code F 76 STANAG 1385 Edition 6	NATO Code F 76 DEF-STAN 91-4 Edition 8	NATO Code F 76 MIL-DTL-16884N
Restrictions	- Proportion of water: Max. 200 mg/kg - Total contamination: Max. 24 mg/kg - With exhaust gas aftertreatment: • Max. sulfur content of 15 mg/kg, or is defined series- and application-specifically - Particle distribution for fuel in acc. with table 28 (→ Page 38)		
Series			
099	Approved	Approved if: - density 0.820 to 0.860 g/ml	Approved
183	Approved	Approved if: - density 0.820 to 0.860 g/ml	Approved

TIM-ID: 0000071310 - 005

Fuel specifications	NATO Code F 76 STANAG 1385 Edition 6	NATO Code F 76 DEF-STAN 91-4 Edition 8	NATO Code F 76 MIL-DTL-16884N
Restrictions	- Proportion of water: Max. 200 mg/kg - Total contamination: Max. 24 mg/kg - With exhaust gas aftertreatment: <ul style="list-style-type: none"> Max. sulfur content of 15 mg/kg, or is defined series- and application-specifically - Particle distribution for fuel in acc. with table 28 (→ Page 38)		
Series			
396 C&I, Genset, Marine, Rail, Submarine	upon request	Approved if: - density 0.820 to 0.860 g/ml	upon request
538 Marine	upon request	Approved	upon request
595 Marine	Approved if: - density 0.820 to 0.860 g/ml - cetane number min. 45 or - cetane index min. 42 - sulfur content max. 0.5% Anti-wear additive necessary if sulfur content < 500 mg/kg	Approved if: - density 0.820 to 0.860 g/ml Anti-wear additive necessary if sulfur content < 500 mg/kg	Approved if: - density 0.820 to 0.860 g/ml - cetane number min. 45 or - cetane index min. 42 Anti-wear additive necessary if sulfur content < 500 mg/kg
956TB31, TB32, TB33 956TB34 Nuclear power station, emergency power	Not approved	Not approved	Not approved
956-01 Marine / Rail 956-02 Marine	Approved if: - density 0.820 to 0.860 g/ml - cetane number min. 45 or - cetane index min. 42 - sulfur content max. 0.5% Anti-wear additive necessary if sulfur content < 500 mg/kg	Approved if: - density 0.820 to 0.860 g/ml Anti-wear additive necessary if sulfur content < 500 mg/kg	Approved if: - density 0.820 to 0.860 g/ml - cetane number min. 45 or - cetane index min. 42 Anti-wear additive necessary if sulfur content < 500 mg/kg
1163-02 TB32 Genset	Not approved	Not approved	Not approved

Fuel specifications	NATO Code F 76 STANAG 1385 Edition 6	NATO Code F 76 DEF-STAN 91-4 Edition 8	NATO Code F 76 MIL-DTL-16884N
Restrictions	- Proportion of water: Max. 200 mg/kg - Total contamination: Max. 24 mg/kg - With exhaust gas aftertreatment: <ul style="list-style-type: none"> • Max. sulfur content of 15 mg/kg, or is defined series- and application-specifically - Particle distribution for fuel in acc. with table 28 (→ Page 38)		
Series			
1163-02 Marine	Approved if:	Approved if:	Approved if:
1163-03 Marine	- density 0.820 to 0.860 g/ml - cetane number min. 45 or - cetane index min. 42 - sulfur content max. 0.5% Anti-wear additive necessary if sulfur content < 500 mg/kg	- density 0.820 to 0.860 g/ml - sulfur content max. 0.5%	- density 0.820 to 0.860 g/ml - cetane number min. 45 or - cetane index min. 42 - sulfur content max. 0.5% Anti-wear additive necessary if sulfur content < 500 mg/kg
1163-04 Marine	Approved if:	Approved if:	Approved if:
	- density 0.820 to 0.860 g/ml - cetane number min. 45 or - cetane index min. 42 - sulfur content max. 0.5%	- density 0.820 to 0.860 g/ml	- density 0.820 to 0.860 g/ml - cetane number min. 45 or - cetane index min. 42

Table 53:

- Other qualities on request

NATO diesel fuels

Diesel fuel NATO Code F-54

Two-stroke cycle engines

Fuel specifications	NATO Code F-54 in accordance with TL 9140-0001 Edition 8	NATO Code F-54 in accordance with STANAG 7090 Edition 4
Restrictions	Approval if fuel corresponds to diesel fuel DIN EN 590:2014-04 - Total contamination: Max. 24 mg/kg - Lubricity: Max. 520 µm Furthermore: - SOLAS: Flashpoint min. 60 °C - With exhaust gas aftertreatment: • Max. sulfur content of 15 mg/kg, or is defined series- and application-specifically - Particle distribution for fuel in acc. with table 28 (→ Page 38)	Approval if fuel corresponds to diesel fuel DIN EN 590:2014-04 - Density: Min. 0.820 g/ml - Total contamination: Max. 24 mg/kg - Lubricity: Max. 520 µm Furthermore: - SOLAS: Flashpoint min. 60 °C - With exhaust gas aftertreatment: • Max. sulfur content of 15 mg/kg, or is defined series- and application-specifically - Particle distribution for fuel in acc. with table 28 (→ Page 38)
Series		
S53, S71, S92, S149	Approved if lubricity max. 460 µm	

Table 54:

Diesel fuel NATO Code F-75

Two-stroke cycle engines

Fuel specifications	NATO Code F 75 TL 9140-0003	NATO Code F 75 STANAG 1385
Comments	- Reduced power possible due to min. density of 0.815 g/ml	- Possible power reduction and increase due to density range of 0.815 to 0.880 g/ml - max. sulfur content 1.0% → Adapt oil and oil change interval
Restrictions	- With exhaust gas aftertreatment: • Max. sulfur content of 15 mg/kg, or is defined series- and application-specifically - Particle distribution for fuel in acc. with table 28 (→ Page 38)	- Proportion of water: Max. 200 mg/kg - Total contamination: Max. 24 mg/kg With exhaust gas aftertreatment: • Max. sulfur content of 15 mg/kg, or is defined series- and application-specifically - Particle distribution for fuel in acc. with table 28 (→ Page 38)
Series		
S53, S71, S92, S149	Not approved	Not approved

Table 55:

Diesel fuel NATO Code F-76

Two-stroke cycle engines

Fuel specifications	NATO Code F 76 STANAG 1385 Edition 6	NATO Code F 76 DEF-STAN 91-4 Edition 8	NATO Code F 76 MIL-DTL-16884N
Restrictions	<ul style="list-style-type: none"> - Proportion of water: Max. 200 mg/kg - Total contamination: Max. 24 mg/kg - With exhaust gas aftertreatment: <ul style="list-style-type: none"> • Max. sulfur content of 15 mg/kg, or is defined series- and application-specifically - Particle distribution for fuel in acc. with table 28 (→ Page 38) 		
Series			
S53, S71, S92, S149	Not approved	Not approved	Not approved

Table 56:

- Other qualities on request

5.2.8 Paraffinic diesel fuel according to DIN EN 15940

Standards define paraffinic diesel fuels as being fuels produced by synthesis or hydrogenation processes. Such fuels are referred to as synthetic fuels below.

Important

Project-specific approval from Rolls-Royce Solutions GmbH is possible upon request.

Selected synthetic diesel fuels according to DIN EN 15940 are currently in the qualification phase.

The following Series have gained approval for the use of synthetic diesel fuels according to DIN EN 15940:

Series	Remarks
S4000Gx3	All years of manufacture
S4000Gx4	All years of manufacture

Table 57:

This approval covers the emission levels listed below:

- Fuel optimized
- NOx optimized
- EPA Nonroad T2 Compliant (40 CFR 89)
- NEA Singapore for Off Road Diesel Engines (ORDE)

5.2.9 Engine operation on diesel fuel with a biodiesel content of up to 30%

Important

Project-specific approval from Rolls-Royce Solutions GmbH is possible upon request.

The term biodiesel is used for what the standards refer to as “FAME” (Fatty Acid Methyl Ester) in this case.

More information about diesel fuel containing up to 30% FAME is provided below and in the Customer Information entitled “Diesel fuel containing up to 30% FAME” (publication number A060632/..).

Use of diesel fuel containing up to 30% FAME

Biodiesel mixtures consist of fuels which are obtained from biogenic raw materials and mixed with conventional diesel fuel. For instance, B20 denotes a mixture comprising 20% biodiesel and 80% fuel based on crude oil/mineral oil. mtu engines were not specially designed to be operated with biodiesel mixtures. For this reason, the use of biodiesel mixtures may have negative effects in terms of engine power, service and maintenance requirements, emissions and useful life.

Operators of mtu engines therefore need to be clear about the effects that biodiesel may have on their engines, and must take all of the necessary measures to ensure the reliability and safety of their engines. This chapter provides Rolls-Royce Solutions customers with important information on the use of biodiesel mixtures in mtu engines and explains the potential impact these fuels may have on the Rolls-Royce Solutions warranty. Please read this information carefully before using biodiesel mixtures in mtu engines.

1. Regarding the use of approved biodiesel mixtures

At present, only biodiesel mixtures with up to 7% biodiesel (in accordance with DIN EN 590) or 5% biodiesel (in accordance with ASTM D 975) are approved for use in these Fluids and Lubricants Specifications.

Although not currently approved in the Fluids and Lubricants Specifications, biodiesel mixtures containing up to 30% biodiesel (B30) may be used in the engines listed in section 6 below,

- PROVIDING THAT the following requirements are met:
 - The biodiesel mixtures are specified according to the following standards:
 1. 3675.K/24/DJM (standard for diesel fuel with 10% biodiesel content, i.e. B10, in Indonesia)
 2. 28.K/10/DJM.T (standard for diesel fuel with 20% biodiesel content, i.e. B20, in Indonesia)
 3. 0234.K/10/DJM.S/2019 (standard for diesel fuel with 30% biodiesel content, i.e. B30, in Indonesia)
 4. DIN EN 16709 (European standard for diesel fuel with 20% and 30% biodiesel content, i.e. B20 and B30)
 5. ASTM D7467 (US standard for diesel fuel with 6% to 20% biodiesel content, i.e. B6 - B20)
 6. The biodiesel used for mixing complies with the DIN EN 14214, ASTM D 6751 or SNI 71825 standards
 7. The distilled diesel fuel used for mixing is approved in the latest version of the Fluids and Lubricants Specifications.
 8. The operator complies with the operating requirements given in section 2 and the additional maintenance recommendations from section 5.

Important

The provisions with regard to requirements placed on fuel may differ depending on legislation and application of the engine. The operator is responsible for ensuring that only fuels which comply with the applicable provisions are used in the engines.

2. Operating requirements for the use of diesel fuels with a biodiesel content of up to 30%

The following operating requirements must be met when biodiesel mixtures are used in mtu engines:

- a For engines used in standby gensets, an additive must be used to improve the oxidation stability of the biodiesel.
- b All engines used in fire-fighting pumps, fire-extinguishing equipment or police equipment must be thoroughly flushed with pure, biodiesel-free, high-quality distilled diesel fuel which complies with the Fluids and Lubricants Specifications each time they are operated with a biodiesel mixture. Furthermore, an additive must be used in these engines to improve the oxidation stability of the biodiesel.
- c All engines which are only used seasonally or which are not operated for extended periods between uses must be thoroughly flushed with pure, biodiesel-free, high-quality distilled diesel fuel which complies with the Fluids and Lubricants Specifications before they are decommissioned.
- d Biodiesel mixtures can not be used in engines equipped with an exhaust gas aftertreatment system (e.g. catalytic converters, particle filters (DPF) and/or systems for reducing NOx emissions, e.g. SCR systems).

3. Impact on the Rolls-Royce Solutions warranty

The manufacturer shall not be responsible for failures which can be attributed to the use of fuels not approved in these Fluids and Lubricants Specifications and such failures shall therefore not be covered by the Rolls-Royce Solutions warranty. Rolls-Royce Solutions shall reject all warranty claims connected to the use of biodiesel mixtures with a biodiesel content of more than 7% (in accordance with DIN EN 590) or 5% (in accordance with ASTM D 975) if the operator is unable to prove that the operating requirements and recommendations contained in this letter were met and strictly followed. Regardless of this, Rolls-Royce Solutions shall on no account be liable for providing compensation for costs arising from the effects described below in section 4.

Important

All properties guaranteed by Rolls-Royce Solutions in terms of assured characteristics with regard to engine power and/or operational availability only apply to the cases in which fuels approved by Rolls-Royce Solutions are used and the engine demonstrates no defects or damage arising from operation with fuels not approved in these Fluids and Lubricants Specifications.

4. Effects of biodiesel on engines/exclusion of liability

The biodiesel contained in biodiesel mixtures is a natural product and therefore undergoes natural aging processes. These may have a negative effect on the engines in which the biodiesel mixtures are used. The effects that biodiesel may have on engines are explained below.

Important: THESE EFFECTS ARE NOT FAULTS CAUSED BY THE ENGINE MANUFACTURER. THEY ARE THEREFORE EXCLUDED FROM THE Rolls-Royce Solutions WARRANTY. ROLLS-ROYCE SOLUTIONS SHALL NOT ASSUME ANY LIABILITY FOR COSTS ARISING FROM THE EFFECTS DESCRIBED BELOW.

- The formation of deposits may cause components to become “sticky”, which potentially restricts their movement. On engines with long downtimes, this can result in a situation where the engine can no longer be started. This is why additives for improving the oxidation stability of the biodiesel must be employed when biodiesel mixtures are used in standby gensets. ROLLS-ROYCE SOLUTIONS SHALL ACCEPT NO LIABILITY IN THE EVENT THAT THE ENGINE IN AN STANDBY GENSET CAN NOT BE STARTED AS A RESULT OF THE FORMATION OF DEPOSITS.
- The formation of deposits may have an adverse effect on the interaction of components inside the unit. This results in an increased risk of components failing, and even the breakdown of entire cylinders. The high operating temperatures in the surroundings encourage the formation of mineral deposits, other deposits and encrustations which may render the valve unable to correctly regulate the fuel supply. This means that it is no longer possible for the quantity of fuel required at full load to be injected into the engine, thereby reducing the maximum engine power.
- The viscosity properties of biodiesel are less favorable at low temperatures. The use of biodiesel at low temperatures may therefore cause the fuel filter to become clogged.
- On all engines, lubricating the piston skirts with oil leads to a small amount of fuel entering the engine oil. This is generally of little importance with conventional diesel fuels in accordance with these Fluids and Lubricants Specifications since the fuel evaporates quickly upon reaching the operating temperature. On the other hand, biodiesel evaporates much less effectively, with the result that more biodiesel accumulates in the oil. Aging of the biodiesel can therefore cause residues to form, filters to become clogged and ultimately cause the engine to come to a stop, resulting in significantly shorter oil change intervals.
- Compared to conventional diesel fuels according to these Fluids and Lubricants Specifications, biodiesel has a lower energy density. Operating the engine with B20 results in a power reduction of approximately 2% and an increase in fuel consumption of around 3%.
- Biodiesel contains chemical components which can interact with the sensors in the exhaust gas recirculation system in such a way that incorrect data is reported to the engine control system. This can have consequences such as engine operation being adapted to the wrong values and emissions therefore no longer complying with the applicable provisions. This is why biodiesel must not be used in engines which feature exhaust gas recirculation (EGR) and/or exhaust gas aftertreatment systems.
- Compared to conventional diesel fuels according to these Fluids and Lubricants Specifications, biodiesel has a higher water solubility, meaning that a higher proportion of water should be expected depending on the fuel temperature. This can lead to increased corrosion and faster microbe growth in the fuel system. Due to the higher proportion of water in biodiesel, reduced water separator performance must be expected.
- Biodiesel is a solvent. After switching over to a biodiesel mixture, impurities and certain deposits may become loose in the tank and lines, causing the fuel filter to be subjected to an increased accumulation of these. Biodiesel mixtures may also strip paint when they come into contact with painted surfaces.
- On engines with exhaust gas aftertreatment systems, the functioning of the catalytic converter may be impaired as biodiesel mixtures can contain a higher proportion of trace elements (e.g. calcium, magnesium, sodium, potassium and phosphorus) than conventional diesel fuels according to these Fluids and Lubricants Specifications. This means that the legally prescribed emissions limits are not complied with and the operating license becomes invalid. Furthermore, legally prescribed technologies for checking emissions on these engines (e.g. NOx monitoring diagnostics) lead to a significant decrease in engine power. The above-mentioned trace elements may also result in excess ash formation and accumulations in the soot filters and catalytic converters. Excess ash formation results in a constantly rising exhaust back pressure and can therefore cause a slow reduction in engine power.

The above-mentioned points do not constitute a complete risk assessment. Rolls-Royce Solutions is unable to assess all biodiesel variants and their long-term effects on mtu products.

5. Additional maintenance recommendations

The following requirements must be met to ensure the quality and operational availability of your engine:

- Select the highest possible content of distilled fuel. Only use fuels approved in these Fluids and Lubricants Specifications.
- After switching over to a biodiesel mixture, replace the fuel filters after 50 operating hours at the latest (in order to remove the impurities which become loose from the tank and lines).
- The fuel filters and fuel prefilters must be renewed every 250 operating hours.
- Install a fuel preheating system if the engine is operated at temperatures below 0 °C (32 °F). This can reduce the negative effect on the fuel supply.
- Follow the recommendations below with regard to engine oil and maintenance:
 - If biodiesel mixtures are used, the change intervals for engine oil and filters must be halved in comparison to the intervals stated in these Fluids and Lubricants Specifications.
 - The component TBO of the LP fuel pump, the O-rings in the LP fuel system as well as the valves in the fuel filter head is shortened to TBO/3.
 - In addition to changing the oil and filters on time, the engine oil and filters must be analyzed regularly in order to ensure that the oil quality is correct. Interval: Every 100 operating hours or every three months, depending on which comes first. A decision must be made to either further reduce or extend the change intervals on the basis of the results.
 - The oil and oil filter must be replaced before biodiesel is used.
 - High-quality engine oil must be used. Operating the engine without high-quality category 2 oil leads to a deterioration in oil quality. These Fluids and Lubricants Specifications contain a list of approved oil types.
- Use a suitable tank and line system:
 - Do not use any components which contain zinc, copper or NBR seals.
 - Ensure that the system can be filled up to the fill line.
 - Minimize the entry of atmospheric oxygen through the tank vent in the event of temperature fluctuations, etc. (e.g. by installing a pressure relief valve and filter; contact your tank supplier to do this).
 - It is recommended to use a tank vent with humidity separator.
- For systems without a water separator: Retrofit a water separator to reduce the risk of microbe growth and corrosion in the fuel system.
- Regular maintenance of the water separator is mandatory. Separated water must be drained off daily, depending on the water quantity.
- Avoid longer engine downtimes and temporary shutdowns (>1 week for B20 or >3 days for B30). If downtimes can not be avoided, a suitable additive must be used to improve oxidation stability. Rolls-Royce Solutions can recommend a suitable additive on request.
- For B30:
 - The engine must be started once within 24 hours and run at idle for 5 minutes.
- For engines used seasonally, we strongly recommend flushing the fuel system, including the fuel tank, with pure, biodiesel-free, high-quality distilled diesel fuel in accordance with these Fluids and Lubricants Specifications before the engine is shut down for a relatively long period (>1 week for B20 or >3 days for B30). The reason for this is the lack of empirical data for the country-specific fuel specification.
- Prevent biodiesel from coming into contact with painted surfaces to avoid damaging and stripping the paint.
- Furthermore, always ensure that the most recent version of the Fluids and Lubricants Specifications is available and its contents are observed.

More extensive preventative measures are additionally required for some applications. Our product support department is available to answer any questions you may have on this topic.

6. Affected engines

This customer information applies to the following engine series:

Series	Remarks
S1600Gx0	All years of manufacture
S2000Gx2	All years of manufacture
S2000Gx3	With metal low-pressure fuel lines
S2000Gx4	All years of manufacture
S2000Gx5	All years of manufacture
S2000Gx6	All years of manufacture
S4000Cx0	All years of manufacture
S4000Cx1	All years of manufacture
S4000Gx1	With metal low-pressure fuel lines
S4000Gx2	All years of manufacture
S4000Gx3	All years of manufacture
S4000Gx4 except for G44F, G44LF, G94F, G94LF	All years of manufacture
S4000Mx0	All years of manufacture
S4000Mx1	All years of manufacture
S4000Mx3	All years of manufacture
S1163Mx4	All years of manufacture
S8000Mx1	All years of manufacture

Table 58: For the use of fuels containing up to 20% biodiesel (B20)

Series	Remarks
S4000Gx3	All years of manufacture
S4000Gx4 except for G44F, G44LF, G94F, G94LF	All years of manufacture
S4000Mx0	All years of manufacture
S4000Mx1	All years of manufacture
S4000Mx3	All years of manufacture
S1163Mx4	All years of manufacture
S8000Mx1	All years of manufacture

Table 59: For the use of fuels containing more than 20% biodiesel (B20) up to a maximum biodiesel content of 30% (B30)

Should you have any questions about this customer information, please contact your local Rolls-Royce Solutions representative.

5.3 Engine operation on pure biodiesel (B100) and vegetable oil

The standardized generic term “FAME”, (Fatty Acid Methyl Ester) is used here to designate biodiesel fuels.

General information

- We can make no comment with regard to the level of FAME resistance of the fuel system, which is not part of our scope of supply.
- FAME is an extremely effective solvent. Any contact with paint, for example, must therefore be avoided.
- The characteristic smell of FAME exhaust, especially during long periods of idling, may be perceived as unpleasant. The nuisance caused by smell can be reduced by an oxidation catalyst which may be installed by the vehicle / equipment manufacturers at their own risk.

Important

Our company accepts no responsibility for and provides no warranty in respect of any fault or damage connected in any way with the use of FAME of a lower quality or resulting from noncompliance with our specifications on operation using FAME. All resultant irregularities and consequential damage lie outside our responsibility.

The following engines are approved/not approved for operation with 100% FAME in compliance with DIN EN 14214:2019-05.

Approved/non-approved engines for operation with 100% FAME

Series	Approved / Not approved	Conversion necessary
SUN		Not approved
700		Not approved
750		Not approved
OM 457 LA	From series introduction	no
460	From series introduction	no
900	From series introduction	no
500	From series introduction	no
S40		Not approved
S50		Not approved
S60		Not approved
183		Not approved
2000		Not approved
396		Not approved
4000		Not approved
538		Not approved
595		Not approved
956		Not approved
1163		Not approved
8000		Not approved

Table 60:

Important

Diesel fuel with a FAME content of max. 7% in compliance with DIN EN 590:2017-10 may be used. Such fuel may also be used in engines which have not been approved for operation with FAME, without affecting oil drain intervals.

Fuel

- The FAME must comply with DIN EN 14214:2019-05. Operation with fuels of lower quality can lead to damage and malfunctions.
- Either FAME or diesel fuel may be used. The various mixtures of FAME and normal diesel fuel, which may occur in the fuel tank as a result, present no problems.

Engine oil and servicing

- For operation using 100% FAME, engine oils are to be preferred which comply with MB Fluids and Lubricants Specifications, Sheet 228.5 or Oil Category 3 in accordance with these Fluids and Lubricants Specifications. Engine oils in accordance with Sheet 228.3 or Oil Category 2 as per these Fluids and Lubricants Specifications may also be used provided that oil drain intervals are reduced.
- A certain amount of fuel always finds its way into the engine oil via the pistons and cylinders. Its high boiling point means that FAME does not evaporate but remains in the engine oil in its entirety. Under certain conditions chemical reactions may take place between FAME and the engine oil. This can lead to engine damage.
- In case of straight FAME operation, therefore, the change intervals for engine oil and oil filters must be reduced.
- For Series 457, 460, 900 and 500 engines, special equipment is available which facilitates an increase in the engine oil change intervals for operation with 100% FAME (→ Table 61). This involves fitting the engines with special equipment Code MK21 (special unit pump) and Code MK04 (fuel prefilter with heated water separator).

Effects on the engine oil change interval with operation with 100% FAME

Engine version	Engine oil change interval
Engines not fitted with special equipment for operation with FAME	Reduction of engine oil change interval to 30% of the standard interval required for operation with fossil diesel fuels
Engines fitted with special equipment Code MK21 and Code MK04	Reduction of engine oil change interval to 50% of the standard interval required for operation with fossil diesel fuels

Table 61:

Important
The relevant engine oil change intervals must be complied with without fail! Exceeding the engine oil change intervals can cause engine damage!

- Operation with 100% FAME requires shortened fuel filter change intervals. A new fuel filter must be fitted each time the engine oil is changed.
- FAME has a high cleaning effect, which results in a risk of clogging by loosened deposits. If a switch has been made to FAME, a fuel filter and engine oil change should therefore be carried out after approx. 25 operating hours.
- Over longer periods, fuel filter service life may be reduced as a result of old residues being carried into the filter from the fuel system. A special, approved fuel prefilter can be installed as an improvement. This fuel prefilter with heated water separator is already installed on engines fitted with special equipment Code MK04.

Engine power and engine standstill

- Due to its calorific value, operation with 100% FAME involves a reduction of approx.8% to 10% in engine power. This leads to a corresponding increase in fuel consumption as compared to operation with diesel fuel. Engine power corrections are not permissible.
- Prior to any extended period out of operation, the fuel system must be flushed out in order to prevent congestion. To do this, the engine must be flushed for at least 30 minutes with pure, biodiesel-free, high-grade distilled diesel fuel in accordance with these Fluids and Lubricants Specifications.

Vegetable oils as an alternative to diesel fuel

Important

The use of pure vegetable oils as an alternative to diesel fuel or FAME is strictly prohibited due to negative experience (engine damage caused by coking, deposits in the combustion chambers and oil sludge)!

5.4 Diesel fuels for engines with exhaust gas aftertreatment (EGAT)

Engines with exhaust gas aftertreatment place special demands on the fuels used to guarantee the operational reliability and service life of the exhaust system and the engine.

Depending on the technology used for exhaust gas aftertreatment, the following fuels can be used:

Exhaust gas technology	Technical approval for					
	DIN EN 590:2017-10	ASTM D975-19 Grade 1-D	ASTM D975-19 Grade 2-D	DMX in accordance with DIN ISO 8217:2018-10	DMA in accordance with DIN ISO 8217:2018-10	Heating oil EL low-sulfur in accordance with DIN 51603: 2020-09
Restrictions:						
Oxidation catalyst DOC (without particulate filter)	No restriction	S15	S15	Not approved	Not approved	Not approved
Particle oxidation catalyst (POC)	Ash <10 mg/kg	S15 Ash <10 mg/kg	S15 Ash <10 mg/kg	Not approved	Not approved	Not approved
SCR system with vanadium catalysts (no particulate filter)	Series 4000-M05 EPA T4 → no approval	S15 S<500 mg/kg with individual case approval Series 4000-M05 EPA T4 → no approval Series 4000-M03/M05 IMO III → S <1000 mg/kg	S15 S<500 mg/kg with individual case approval Series 4000-M05 EPA T4 → no approval Series 4000-M03/M05 IMO III → S <1000 mg/kg	Individual case approval Series 4000-M05 EPA T4 → no approval Series 4000-M03/M05 IMO III → S <1000 mg/kg		Series 4000-M05 EPA T4 → no approval Series 4000-M03/M05 IMO III → S <1000 mg/kg
SCR system with zeolith catalysts (no particulate filter)	No restriction	S15 Series 4000-M03 IMO III → S <1000 mg/kg	S15 Series 4000-M03 IMO III → S <1000 mg/kg	Not approved Series 4000-M05 EPA T4 → no approval Series 4000-M03 IMO III → S <1000 mg/kg	Not approved Series 4000-M05 EPA T4 → no approval Series 4000-M03 IMO III → S <1000 mg/kg	Not approved Series 4000-M05 EPA T4 → no approval Series 4000-M03 IMO III → S <1000 mg/kg

TIM-ID: 0000057608 - 007

Exhaust gas technology	Technical approval for					
	DIN EN 590:2017-10	ASTM D975-19 Grade 1-D	ASTM D975-19 Grade 2-D	DMX in accordance with DIN ISO 8217:2018-10	DMA in accordance with DIN ISO 8217:2018-10	Heating oil EL low-sulfur in accordance with DIN 51603: 2020-09
Diesel particulate filter (DPF)	Ash <10 mg/kg	S15 Ash <10 mg/kg	S15 Ash <10 mg/kg	Individual case approval		Not approved
Combination system SCR+ particulate filter	Ash <10 mg/kg	S15 Ash <10 mg/kg	S15 Ash <10 mg/kg	Individual case approval		Not approved

Table 62: Diesel fuels for engines with exhaust gas aftertreatment

If the specifications from the tables are not observed, the prescribed TBO can not be guaranteed.

Warranty claim cases that result from the use of an impermissible fuel quality shall be rejected.

If a fuel is present that does not comply with the specifications, in certain circumstances Rolls-Royce Solutions can assist in the selection of corresponding improvement measures.

Any possible restrictions related to engine requirements must also be observed.

Important

Diesel fuel with a proportion of biodiesel (FAME, fatty acid methyl ester) of max. 7% in accordance with DIN EN 590:2017-10 may be used. The use of fuels with an increased proportion of biodiesel is not permitted for plants with exhaust gas aftertreatment because trace elements they may contain can act as catalyst poisons and lead to filter obstructions.

Important

Commercially available diesel fuels normally contain considerably less ash-forming agents than those certified by the relevant standards (typical ash content max. 0.001 % = 10 mg/kg). The particulate filters are designed for these low loads accordingly because the exhaust system would otherwise be completely overdimensioned. The maximum ash content in fuel specified by Rolls-Royce Solutions has been defined to ensure that the particulate filter reaches the assured service life without the back pressure of the filter becoming too high for the engine.

Important

The use of fuel additives for minimizing wear is not permitted on plants with exhaust gas aftertreatment!

Use of fuel additives for lowering soot regeneration temperature on plants with particulate filters

Fuel additives for lowering the soot regeneration temperature (FBC, fuel borne catalyst) are generally not approved. The exhaust aftertreatment systems from Rolls-Royce Solutions are designed such that soot regeneration takes place without additives.

5.5 Heating oil EL

Heating oil differs from diesel fuel mainly because of the following non-specified characteristics:

- Cetane number
- Sulfur content
- Oxidation stability
- Corrosion effect on copper
- Lubricity
- Low temperature behavior

If the heating requirements comply with the specifications of the diesel fuel DIN EN 590:2019-05 (summer and winter quality), there are no technical reasons why it can not be used in the diesel engine

5.6 Supplementary fuel additives

Supplementary fuel additives

The engines are designed such that satisfactory operation with normal, commercially available diesel fuels is ensured. Many of these fuels already contain performance-enhancing additives.

The additives are added by the supplier as the agent responsible for product quality.

The anti-wear additives (→ Page 101) and biocides (→ Page 102) provide an exception.

Important

Attention is drawn to the fact that the use of diesel fuels or additives other than those stipulated in these Fluids and Lubricants Specifications is always the responsibility of the operator.

Diesel fuels with sulfur content < 500 mg/kg

Excessive valve-seat wear occurs on engine series featuring cylinder heads without valve-seat inserts (both inlet and exhaust valves) when low-sulfur fuel grades are used (sulfur content < 500 mg/kg). This applies to the following engine series:

Series	Use of additives
331 up to year of manufacture 1969	Yes*
362	Yes*
396 up to year of manufacture 1975	Yes*
493	Yes*
538	Yes
595	Yes
652	Yes*
956	Yes
1163 up to model type 01-03	Yes*

Table 63:

* = if the cylinder head features valve seat inserts, it is not necessary to use an anti-wear additive in the fuel.

If anti-wear additives are mixed in, this wear can be reduced. The approved supplementary additives must be mixed with the fuel in the predefined concentration. The additive must be filled before every refueling.

Approved anti-wear additives

Manufacturer	Brand name	Concentration for use
The Lubrizol Corporation 29400 Lakeland Boulevard Wickliffe, Ohio 44092 USA Tel. 01 440-943-4200	ADX 766 M	250 to 350 mg/kg
Tunap Industrie GmbH Bürgermeister-Seidl-Str. 2 82515 Wolfratshausen Tel. +49 (0) 8171 1600-0 Fax. +49 (0) 8171 1600-91	Tunadd PS	250 to 350 mg/kg

Table 64:

Important

The use of anti-wear additives is not permitted on engines/plants with exhaust gas aftertreatment!

Microorganisms in fuel

Bacterial attack and sludge formation may occur in the fuel under unfavorable conditions. In such cases, the fuel must be treated with biocides in accordance with the manufacturer's specifications. Overconcentration must always be avoided.

The biocides approved by Rolls-Royce Solutions are listed in table (→ Page 102).

Approved biocides

Biocides should have a pure hydrocarbon structure, i.e. should only consist of the following components:

- Carbon
- Hydrogen
- Oxygen
- Nitrogen

They must not contain inorganic substances because they can cause damage to the engine and the exhaust gas aftertreatment system. The use of halogenated biocides is prohibited due to their effects on the engine system and the environment.

Biocides that contain neither inorganic nor halogenated substances may be used for engine systems with exhaust gas aftertreatment.

Approval for biocides that meet the above requirements is possible upon request.

Manufacturer	Brand name	Concentration for use
ISP Biochema Schwaben GmbH Ashland Specialty Ingredients Luitpoldstrasse 32 87700 Memmingen Tel. +49 (0)8331 9580 0 Fax. +49 (0)8331 9580 51	Bakzid	100 ml / 100 l
Maintenance Technologies Paddy's Pad 1056 CC t/a Maintenance Technologies Tel. +27 21 786 4980 Cell +27 82 598 6830	Diesalcure Fuel Decontaminant	1 : 1200 (833 mg/kg)
Adolf Würth GmbH & Co. KG Reinhold Würth-Straße 12-17 74653 Künzelsau Tel. +49 (0)7940 152248	Diesalcure Fuel Decontaminant	1 : 1200 (833 mg/kg)
Vink Chemicals GmbH & Co.KG Eichenhöhe 29 21255 Kakenstorf Tel. +49 (0)4186 887970 email: info@vink-chemicals.com	grotamar 71 grotamar 82 StabiCor 71	0.5 l / ton 1.0 l / 1000 l 0.5 l / ton
DOW® https://www.dow.com/en-us/about-dow/locations	Kathon™ FP 1.5 Biocide	100-200 mg/kg

TIM-ID: 0000018624 - 009

Manufacturer	Brand name	Concentration for use
Supafuel Marketing CC PO Box 1167 Allens Nek 1737 Johannesburg South Africa Tel. +27 83 6010 846 Fax. +27 86 6357 577	Dieselfix / Supafuel	1:1200 (833 mg/kg)
Wilhelmsen Ships Service AS Willem Barentszstraat 50 3165 AB Rotterdam-Albrtand- swaard Tel. +31 10 487 7777 Fax. +31 10 487 7888 Netherlands	DieselPower Biocontrol (previously Dieselpower MAR7 1)	333 ml / ton

Table 65:

Flow improvers

Flow improvers can not prevent paraffin precipitation but they do influence the size of the crystals and thus allow the diesel fuel to pass through the filter.

The effectiveness of the flow improvers is not guaranteed for every fuel.

Certainty is only assured after laboratory testing of the filtering capability.

Required quantities and mixing procedures must be carried out according to the manufacturer's instructions.

5.7 Unsuitable materials in the diesel fuel circuit

Components made of copper and zinc materials

Even small amounts of zinc, lead and copper may leave deposits in diesel fuel injection systems, particularly in modern, state-of-the-art injection systems. For this reason, levels of zinc, lead or copper in tanks, fuel lines and filter elements shall not exceed the manufacturer's validated specifications.

Avoid using materials containing these metals as this may initiate catalytic reactions in the fuel leading to undesirable deposits in the injection system.

Requirements

Based on current knowledge, the following materials and coatings must not be used in a diesel fuel circuit because negative mutual reactions can occur even with approved coolant additives.

Metallic materials

- Zinc, also as surface protection
- Zinc-based alloys
- Copper
- Copper-based alloys with the exception of CuNi10 and CuNi30 (e.g. seawater cooler)
- Tin, also as surface protection
- Magnesium-based alloys

Non-metallic materials

- Elastomers: Nitrile butadiene rubber, natural rubber, chloroprene rubber, butyl rubber, EPDM
- Silicone elastomer
- Fluorosilicone elastomer
- Polyurethane
- Polyvinyl

Information:

Consult the relevant Rolls-Royce Solutions specialist department in case of doubt about the use of materials on the engine / externally mounted components in fuel circuits.

6 NOx Reducing Agent AUS 32 / AUS 40 for SCR Exhaust Gas Aftertreatment Systems

6.1 General information

SCR (Selective Catalytic Reduction) catalysts can be used for NO_x emissions reduction. The reducing agent (urea solution with an urea concentration of 32.5% or 40%) in such catalysts reduces the nitrogen oxide emissions.

To ensure efficient operation of the exhaust gas aftertreatment system, compliance of the reducing agent with the quality requirements stipulated in DIN 70070 / ISO 222 41-1 or ISO 186 11-1 is mandatory.

With ISO 186 11-1, the cleanness requirements (→ Table 65) that deviate from the standard must be observed.

In Europe, this reducing agent is often offered under the brand name “AdBlue”.

The test methods to determine the quality and characteristics of the reducing agent are specified in the standards DIN 70071 / ISO 222 41-2 / ISO 186 11-2. The following table (→ Page 105) shows the quality characteristics and associated test procedures for reducing agents (extract from the standard ISO 222 41-1 and ISO 186 11-1).

SCR systems from mtu are usually designed for a concentration of 32.5% urea.

The use of the NOx reducing agents with 40% (AUS40) is also permitted for Series 2000 marine engines featuring SCR (12V2000M41A IMO III / 2000Mx7).

For Series 4000 marine engines with SCR, Series 4000 M03 (8V4000M63 IMO III / 12V4000M73L, M93, M93L / 16V4000M73, M73L, M93 / 20V4000M73L, M93 / 20V4000M53B IMO III) and Series 4000 M05, the use of the NOx reducing agent with 40% urea (AUS40) is also permitted.

Important

The purity requirements for the reducing agent then correspond to those in the standards for AUS 32 / AUS 40 (in accordance with ISO 222 41-1 or ISO 186 11-1, see table (→ Page 105)).

The use of AUS 32 or AUS 40 with a lower purity level can lead to shortened maintenance intervals for the SCR substrates.

A mixture in the tank of 32.5% and 40% reducing agent is permitted for the above-mentioned engines.

Important

The use of antifreeze additives for AUS 32 and AUS 40, or winter urea, is generally not approved.

Quality parameters and test procedures for reducing agent AUS 32 / AUS 40

	Unit	Test method ISO	Limit values for AUS 32	Limit values for AUS 40
Urea content	by weight %	186 11-2 Annex B	31.8 - 33.2	39 - 41
Spec. gravity at 20 °C	kg/m ³	3675 12185	1087.0 - 1092.0	1105 - 1177
Refractive index at 20 °C		186 11-2 Annex C	1.3817 - 1.3840	1.3947 - 1.3982
Alkalinity as NH ₃	by weight %	186 11-2 Annex D	Max. 0.2	Max. 0.5
Biuret content	by weight %	22241-2 Annex E	Max. 0.3	Max. 0.3

	Unit	Test method ISO	Limit values for AUS 32	Limit values for AUS 40
Aldehyde content	mg/kg	2224 1-2 Annex F	Max. 5	Max. 5
Non-soluble constituents	mg/kg	2224 1-2 Annex G	Max. 20	Max. 20
Phosphate content as PO ₄	mg/kg	2224 1-2 Annex H	Max. 0.5	Max. 0.5
Metal contents		2224 1-2 Annex I		
Calcium	mg/kg		Max. 0.5	Max. 0.5
Iron	mg/kg		Max. 0.5	Max. 0.5
Copper	mg/kg		Max. 0.2	Max. 0.2
Zinc	mg/kg		Max. 0.2	Max. 0.2
Chrome	mg/kg		Max. 0.2	Max. 0.2
Nickel	mg/kg		Max. 0.2	Max. 0.2
Aluminum	mg/kg		Max. 0.5	Max. 0.5
Magnesium	mg/kg		Max. 0.5	Max. 0.5
Sodium	mg/kg		Max. 0.5	Max. 0.5
Potassium	mg/kg		Max. 0.5	Max. 0.5
Identity		ISO 2224 1-2 Annex J	Identical with the reference sample	Identical with the reference sample

Table 66:

Storage of reducing agent

For instructions on storage, packing, transport and suitable/unsuitable materials in the reducing agent circuit, refer to the standard ISO 222 41-3 or ISO 186 11-3. The instructions of the manufacturer must be observed.

Important
<p>AUS 32 (AdBlue) crystallizes at -11 °C. AUS 40 (AdBlue) crystallizes at 0 °C. Avoid direct sunlight because it promotes the occurrence of microorganisms and the decomposition of the reducing agent.</p>

7 Approved Engine Oils and Lubricating Greases

7.1 Engine Oils for Four-Cycle Engines

7.1.1 Series-based usability of engine oils of oil category 1

Series	Oil category 1 Single-grade oils SAE30/40	Oil category 1 Multi-grade oils	Remarks
S60	no	no	
099	yes	yes	
183	yes	yes	
396	yes	yes	
538	yes	yes	
595	yes	yes	Not for fast commercial vessels
956	no	no	All applications
1163-01 Marine	yes	yes	Not for fast commercial vessels
1163-02 Marine	no	no	Not for fast commercial vessels
1163-02 TB32 emergency power, genset	no	no	
1163-03 Marine	yes	yes	
1163-04 Marine	no	no	
2000Mx2 / Mx3	yes	yes	
2000Cx6 / Gx6 / Gx7 / Mx4 / Mx6 / Mx7 / Sx6	no	no	
2000Cx0 / Cx1 /Cx2	yes	yes	
2000Gx5	yes	yes	
2000Mx0 / Mx1	yes	yes	
2000M4 1A IMO III	no	no	
2000Px2	yes	yes	
2000Sx0 / Sx1 / Sx2	yes	yes	
4000-00	yes	yes	
4000-01	yes	yes	
4000-02	yes	yes	
4000-03G (applica- tion group 3A) / S/ P / C / R	yes	yes	
4000-03G except application group 3A	no	no	

Series	Oil category 1 Single-grade oils SAE30/40	Oil category 1 Multi-grade oils	Remarks
4000M23F - M63L	yes	yes	Not permitted for operation with SCR systems (Selective Catalytic Reduction)
4000M23S	yes	yes	Not permitted for operation with SCR systems (Selective Catalytic Reduction)
4000-03M53B / M73-M93L / N43 / N83	no	no	
4000-03M73- M93L IMO II SCR ready	no	no	
4000-03M73- M93L IMO III	no	no	
4000-03R63x	no	no	
12V4000U83	no	no	
4000-04B	yes	yes	
4000-04C	no	no	
4000-04G	no	no	
4000-04M	no	no	
4000-04T	no	no	
4000-05G / T / C	no	no	
4000-05 M IMO II	no	no	
4000-05 M IMO III	no	no	
20V4000M53B IMO III	no	no	
8V4000M63 IMO III	no	no	
8000	no	no	

Table 67:

yes = approved

no = not approved

7.1.2 Single-grade oils – Category 1, SAE grades 30 and 40 for diesel engines

For details and special features, see chapter "Lubricants for four-cycle engines" (→ Page 7)

Single-grade oils

Single-grade oils – Category 1, SAE grades 30 and 40 for diesel engines						
Manufacturer	Brand name	SAE viscosity class	TBN			Remarks
			8 to 10 mgKOH/g	10 to 12 mgKOH/g	>12 mgKOH/g	
Addinol Lube Oil	Addinol Marine MS4011	40	X			
	Addinol Turbo Diesel MD305	30		X		
	Addinol Turbo Diesel MD405	40		X		
Aegean Oil SA	Vigor Super D	40	X			
Castrol Ltd.	Castrol MLC	30, 40		X		
Cepsa Lubricantes	Cepsa Rodaje Y Proteccion	30	X			Enhanced corrosion protection
Gulf Oil International	Gulf Superfleet	40	X			
LPC S.A.	Cyclon D Prime	30, 40	X			
Motor Oil (Hellas)	EMO Turbo Champion Plus	30, 40	X			
	EMO Turbo Champion	40		X		
Petrobras Distribuidora S.A.	Marbrax CCD-310	30		X		
	Marbrax CCD-410	40		X		
PT. Pertamina Lubricants	Meditiran SMX	40	X			
PTT Public Comp.	PTT Navita MTU Type 1	40	X			
Repsol Lubricantes y Especialidades, S.A.	Repsol Serie 3	30, 40		X		
	Repsol Marino 3	30		X		
	Repsol Marino 3 SAE 40	40			X	
SRS Schmierstoff Vertrieb GmbH	SRS Rekord	30, 40		X		
Shell International Petroleum Company	Shell Gadinia S3	30, 40		X		
	Shell Rimula R3	30, 40	X			
	Shell Rimula R3+	30	X			
	Sirius	30	X			
	Shell Sirius Monograde	30, 40	X			
SK Lubricants	SD 5000	40	X			
Total Lubrificants	Total Caprano TD 30	30		X		
	Total Caprano TD 40	40		X		
United Oil	XD 7000 Extra Duty-3U		X			
	XD 7000 Extra Duty-4U		X			

Table 68:

7.1.3 Multigrade oils – Category 1, SAE grades 15W-40 for diesel engines

For details and special features, see chapter "Lubricants for four-cycle engines" (→ Page 7)

Important

²⁾ = Engine oils marked ²⁾ are also approved for Series 60 engines

Multigrade oils

Multigrade oils – Category 1, SAE grades 15W-40 for diesel engines

Manufacturer	Brand name	SAE viscosity class	TBN			Remarks
			8 to 10 mgKOH/g	10 to 12 mgKOH/g	>12 mgKOH/g	
Addinol Lube Oil	Addinol Super Star MX 1547	15W-40		X		
Advanced Lubrication Specialties	Translub 15W40 CI-4	15W-40		X		
BP p.l.c.	BP Vanellus Multi	15W-40	X			
ENI S.p.A	eni i-Sigma universal DL	15W-40	X			
Exxon Mobil Corporation	Mobil Delvac Super 1400E	15W-40	X			
Exxon Mobil Corporation	Mobil Delvac XHP	15W-40	X			
Gulf Oil International	Gulf Superfleet	15W-40	X			
Manufacture Zavod imeni Shau-myana	M5z/14D ₂ CE	15W-40			X	
Petrogal, S.A.	Galp Galaxia Super 15W-40	15W-40	X			
Singapore Petroleum Company Limited	SPC SDM 801	15W-40	X			
SRS Schmierstoff Vertrieb GmbH	SRS Primalub	15W-40	X			
Total Lubrifiants	Total Caprano TD	15W-40	X			
Unil Opal	Intercooler 400	15W-40	X			
United Oil	XD 9000 Ultra Diesel-U	15W-40	X			

Table 69:

7.1.4 Series-based usability of engine oils of oil categories 2 and 2.1 (low SAPS oils)

Series	Oil category 2	Oil category 2	Oil category 2.1 (low SAPS oils)	Remarks
	Single-grade oils	Multi-grade oils	Multi-grade oils	
S60	no	restricted ¹⁾	restricted ²⁾	¹⁾ = only 15W-40 and min. API CH-4 ²⁾ = only 15W-40 and min. API CJ-4
099	yes	yes	yes	
183	yes	yes	yes	
396	yes	yes	yes	
538	yes	yes	yes	
595 with carbon scraper ring	yes	yes	yes	
595 without carbon scraper ring	yes	yes	yes	
956	yes	yes	no	
956-01 Marine, Rail	yes	yes	no	
956-02 Marine, Rail	yes	yes	no	
956TB31 Nuclear power station, emergency power	Mobil Delvac 1630 Mobil Delvac 1640 Power Guard® SAE 40 Off Highway Heavy Duty	no	no	
956TB32 Nuclear power station, emergency power	Mobil Delvac 1640 Power Guard® SAE 40 Off Highway Heavy Duty	no	no	
956TB33 Nuclear power station, emergency power $\xi = 9$	Mobil Delvac 1640 Power Guard® SAE 40 Off Highway Heavy Duty	no	no	
956TB33 Nuclear power station, emergency power $\xi = 12$	Mobil Delvac 1640 Power Guard® SAE 40 Off Highway Heavy Duty Sirius X 30	Lukoil Avantgarde Ultra NP 15W40	no	
956TB34 Nuclear power station, emergency power	Mobil Delvac 1640 Power Guard® SAE 40 Off Highway Heavy Duty	Lukoil Avantgarde Ultra NP 15W40	no	
1163-01 Marine	yes	yes	yes	
1163-02 Marine	yes	yes	yes	
1163-02 TB32 nuclear power station, emergency power	Sirius X 30	no	no	
1163-03 Marine	yes	yes	yes	
1163-04 Marine	yes	yes	yes	

Series	Oil category 2	Oil category 2	Oil category 2.1 (low SAPS oils)	Remarks
	Single-grade oils	Multi-grade oils	Multi-grade oils	
2000Mx3 / Mx4	yes	yes	yes	
2000 M72	yes ³⁾	yes	yes	³⁾ = Except: <ul style="list-style-type: none"> • Mobil Delvac 1630/1640 • Power Guard® SAE 40 Heavy Duty • Mobilgard ADL30/40
2000Cx6 / Gx6 / Gx7 / Mx6 / Sx6	yes	yes	yes	
2000Cx0 / Cx1 / Cx2	yes	yes	yes	
2000Gx5	yes	yes	yes	
2000Mx0 / Mx1	yes	yes	yes	
2000M41A IMO III	no	no	yes	
2000Mx7	no	no	yes	
2000Px2	yes	yes	yes	
2000Sx0 / Sx1 / Sx2	yes	yes	yes	
4000-00	yes	yes	yes	
4000-01	yes	yes	yes	
4000-02	yes	yes	yes	
4000-03G / S / P / C / R	yes	yes	yes	
4000-03Gx3F / Gx3G / Gx3H	yes	yes	yes	
4000M23F - M63L	yes ⁴⁾	yes ⁴⁾	yes	⁴⁾ = Not permitted for operation with SCR systems (Selective Catalytic Reduction)
4000M53 / M73-M93L / N43 / N83	yes ⁵⁾	yes ⁵⁾	yes	⁵⁾ = Not permitted for operation with SCR systems (Selective Catalytic Reduction)
4000-03M73-M93L IMO II SCR ready	yes	yes	yes	
4000-03M73-M93L IMO III	no	no	yes	
4000-03R63x	yes	yes	yes	
12V4000U83	yes	yes	yes	
4000-04 B	yes	yes	yes	

Series	Oil category 2		Oil category 2.1 (low SAPS oils)	Remarks
	Single-grade oils	Multi-grade oils	Multi-grade oils	
4000-04 C	no	no	only Fleet Supreme EC 15W-40	
4000-04 G	yes	yes	yes	
4000-04 M	yes	yes	yes	
4000-04 R	no	no	no	
4000-04 T	no	no	only Chevron Delo 400 LE 15W-40	
4000-05 G	no	no	yes	
4000-05 M	yes ⁶⁾	yes ⁶⁾	yes	⁶⁾ = Not permitted for operation with SCR systems (Selective Catalytic Reduction)
4000-05 M IMO II	yes	yes	yes	
4000-05 M IMO III	no	no	yes	
20V4000M53B IMO III	no	no	yes	
8V4000M63 IMO III	no	no	yes	
4000-05T / C	no	no	no	
8000	restricted ⁷⁾	no	no	⁷⁾ = Only named engine oils Re-approval only after engine test in Series 8000

Table 70:

yes = approved

no = not approved

7.1.5 Single-grade oils – Category 2, SAE-grades 30 and 40 for diesel engines

For details and special features, see chapter “Lubricants for four-stroke cycle engines” (→ Page 7)

Important

For Series 8000 engines, the approved SAE grade 40 engine oils may only be used in combination with preheating and oil priming ($T_{oil} > 30\text{ °C}$).

Single-grade oils

Single-grade oils – Category 2, SAE-grades 30 and 40 for diesel engines						
Manufacturer	Product/brand name	SAE viscosity class	TBN			Remarks
			8 to 10 mgKOH/g	10 to 12 mgKOH/g	>12 mgKOH/g	
Rolls-Royce Solutions GmbH	Power Guard® DEO SAE 40	40	X			20 l container: X00062816 210 l container: X00062817 IBC: X00064829
Rolls-Royce Solutions America Inc.	Power Guard® SAE 40 Off-Highway Heavy Duty	40		X		5 gallons: 23532941 55 gallons: 23532942 Approved for Series 8000 [see under Important] Available from Rolls-Royce Solutions America Inc. Not approved for Series 2000 M72
mtu India Pvt Ltd.	Diesel Engine Oil DEO SAE 40	40		X		50 l container: 73333/P 205 l container: 75151/D Sale of Indian oil only intended in Indian market
Addinol Lube Oil GmbH	Addinol Turbo Diesel MD 407	40	X			
Adnoc Distribution	ADNOC Voyager Plus 40 CF/SL	40	X			
Atak Madeni Yag Lubricants	Protector MX 30	30			X	
	Protector MX 40	40			X	
BayWa AG	Tectrol HD 30	30		X		
	Tectrol HD 40	40		X		
Belgin Madeni Yaglar	Lubex Marine M	30		X		
	Lubex Marine M	40		X		
	Lubex Marine LTM-30	30		X		
	Lubex Marine LTM-40	40		X		
Castrol Ltd.	Castrol HLX	30, 40		X		Approved for fast commercial vessels up to 1500 h, Series 595, 1163
Cepsa Lubricants	Cepsa Petrel HDL 40	40			X	

TIM-ID: 0000018996 - 010

Single-grade oils – Category 2, SAE-grades 30 and 40 for diesel engines						
Manufacturer	Product/brand name	SAE viscosity class	TBN			Remarks
			8 to 10 mgKOH/g	10 to 12 mgKOH/g	>12 mgKOH/g	
Chevron Lubricants (Texaco)	Ursa Premium TDX	40		X		
	Delo 400	30, 40		X		
	Delo Gold	40		X		
Chevron – Lyteca – (Texaco)	Ursa Premium TDX	40		X		
Delek	Delkol Super Diesel	40		X		
	Delkol Super Diesel MT Mono	40	X			
ENOC Marketing L.L.C.	ENOC Strata Super Duty	40		X		
Exxon Mobil Corporation	Mobil Delvac 1630	30		X		Not approved for Series 2000 M72
	Mobil Delvac 1640	40		X		Not approved for Series 2000 M72
	Mobilgard ADL 30	30		X		Not approved for Series 2000 M72
	Mobilgard ADL 40	40		X		Not approved for Series 2000 M72
Fuchs Petrolub SE	Titan Universal HD	30, 40	X			
	Titan EM 30 MTU	30	X			Enhanced corrosion protection
	Titan Universal HD SAE 30 MTU	30	X			Enhanced corrosion protection
Gulf Oil International	Gulf Superfleet Plus	40	X			
Gulf Western Oil, Australia	Turboil	40			X	
GS Caltex Corporation	Kixx D1 40	40	X			
	MPA 300 SAE 30	30	X			
	MPA 300 SAE 40	40	X			
Hyrax Oil Sdn Bhd	Hyrax Top Deo	40	X			
Koçak Petrol Ürünleri San. ve. TIC. Ltd.	Speedol Ultra HDX 30 TBN 12	30		X		
	Speedol Ultra HDX 40 TBN 12	40		X		
	Speedol Deniz Dizel Motor Yağı	30, 40		X		
	Speedol Ultra HDX	30, 40	X			
Kuwait Petroleum	Q8 T 750	30, 40	X			
LPC S.A.	Cyclon D Super	40		X		
Manufacture Zavod imeni Shau-myana Ltd.	M-14D2CE	40			X	
Motor Oil, Hellas	EMO SHPD Plus	30, 40		X		
Motorex AG	Motorex Monolube	30		X		
OOO Lukoil International	Lukoil Avantgarde M 40	40	X			

TİM-ID: 0000018996 - 010

Single-grade oils – Category 2, SAE-grades 30 and 40 for diesel engines						
Manufacturer	Product/brand name	SAE viscosity class	TBN			Remarks
			8 to 10 mgKOH/g	10 to 12 mgKOH/g	>12 mgKOH/g	
Oryx Energies	Supreme RR	40			X	
Panolin AG	Panolin Extra Diesel	40	X			
Paz Lubricants & Chemicals	Pazl Marine S 40	40	X			
Petrobras Distribuidora S.A.	Marbrax CCD-3 10-AP	30		X		
	Marbrax CCD-4 10-AP	40		X		
Petrogal, S.A.	Galp Galaxia 40	40		X		
Prista Oil Holding EAD	Prista SHPD 40	40			X	
PTT Public Comp.	PTT Navita MTU Type 2	40		X		
	Navita Plus, SAE 40	40		X		
Repsol Lubricantes y Especialidades, S.A.	Repsol Diesel Serie 3 MT	40			X	
Shell International Petroleum Company	Shell Sirius X	30			X	
	Shell Sirius X	40			X	
Sonol	Seamaster 40	40	X			
SRS Schmierstoff Vertriebs GmbH	SRS Rekord plus 30	30		X		
	SRS Rekord plus 40	40		X		
	SRS Antikorrol M plus	30		X		Enhanced corrosion protection Only permitted for running-in and series acceptance
	SRS Motorenöl O-278	40		X		
Total Lubrifiants	Total Caprano MT 30	30			X	
	Total Caprano MT 40	40			X	
	Total Disola MT 30	30	X			
	Total Disola MT 40	40	X			
	Total Rubia MT 30	30			X	
	Total Rubia MT 40	40			X	
Viva Energy Australia	Penske Power Systems Premium	40			X	

Table 71:

7.1.6 Multi-grade oils – Category 2, SAE grades 10W-30, 10W-40, 15W-40 and 20W-40 for diesel engines

For details and special features, see chapter “Lubricants for four-stroke cycle engines” (→ Page 7)

Important

²⁾ Engine oils marked ²⁾ are also approved for Series 60 engines

Multi-grade oils

Multi-grade oils – Category 2, SAE grades 10W-30, 10W-40, 15W-40 and 20W-40 for diesel engines						
Manufacturer	Product/brand name	SAE viscosity class	TBN			Remarks
			8 to 10 mgKOH/g	10 to 12 mgKOH/g	>12 mgKOH/g	
Rolls-Royce Solutions GmbH	Diesel Engine Oil DEO SAE 15W-40	15W-40		X		20 l container: X00070830 210 l container: X00070832 IBC: X00070833 Loose items: X00070835 (only on request)
Rolls-Royce Solutions Asia Pte. Ltd.	Diesel Engine Oil - DEO 15W-40	15W-40		X		20 l container: 64242/P 205 l container: 65151/D
Rolls-Royce Solutions Suzhou Co. Ltd. China	Diesel Engine Oil - DEO SAE 15W-40	15W-40		X		20 l container: X00064242/P 205 l container: 65151/D
	Diesel Engine Oil - DEO SAE 10W-40	10W-40		X		20 l canister: 60606/P
PT. Rolls-Royce Solutions Indonesia	Diesel Engine Oil - DEO SAE 15W-40	15W40		X		20 l canister: X00064242/P 205 l container: 65151/D
mtu India Pvt. Ltd.	Diesel Engine Oil - DEO 15W-40	15W-40		X		50 l canister: 63333/P ²⁾ 205 l container: 65151/D Sale only intended in Indian market
Adnoc Distribution	Adnoc Voyager Plus	15W-40		X		²⁾
Aegean Oil S.A.	Vigor Turbo SD 15W-40	15W-40	X			²⁾
Addinol Lube Oil	Addinol Super Longlife MD1047	10W-40		X		
	Addinol Diesel Longlife MD1548	15W-40		X		²⁾
AP Oil	AP X-Super Dieselube Turbo CF-4	15W40	X			
Arabi Eneritech KSC	Burgan Ultra Diesel CH-4	15W-40		X		²⁾
Aral AG	Aral Turboral 10W-40	10W-40		X		
	Aral Turboral 15W-40	15W-40		X		²⁾
Aramco Lubricants and Retail Company	Orizon HD vB	15W-40	X			²⁾
	Orizon HD vE	15W-40		X		²⁾

Multi-grade oils – Category 2, SAE grades 10W-30, 10W-40, 15W-40 and 20W-40 for diesel engines

Manufacturer	Product/brand name	SAE viscosity class	TBN			Remarks
			8 to 10 mgKOH/g	10 to 12 mgKOH/g	>12 mgKOH/g	
Atak Madeni Yağ Paz.San.Tic.Aş	Alpet Turbot	10W-40		X		
	Alpet Turbot Fleetmax	15W-40		X		
	Alpet Turbot SHPD	15W-40		X		
	Alpet Turbot XHD	10W-40		X		
Auto-Teile-Ring GmbH	Cartechnic Motorenöl SAE 15W-40	15W-40	X			
Avista Oil Refining & Trading Deutschland GmbH	Avista Advantage SHPD	15W-40	X			
	Avista Advantage UHPD	15W-40	X			
	Pennasol Turbo Super	15W-40		X		2)
	MOTOR GOLD Turbotec	15W-40		X		2)
Bahrain Petroleum Company B.S.C.	Frontier Megatek	10W-40	X			
	Frontier Super Plus	15W-40		X		2)
	Frontier Turbo	15W-40		X		
	Frontier Turbo LD	10W-40		X		
	Frontier Turbo Plus	15W-40		X		2)
BayWa AG	Tectrol Turbo 4000	10W-40		X		
	Tectrol Super Truck 1540	15W-40			X	
Belgin Madeni Yaglar	Lubex Marine M	15W-40		X		
BP p.l.c.	BP Vanellus C6 Global Plus	10W-40		X		
	BP Vanellus Multi-Fleet	15W-40			X	2)
	BP Multi Mine	15W-40	X			2)
	BP Mine Multi 15W-40	15W-40		X		2)
	BP Vanellus Longdrain	15W-40		X		2)
	BP Vanellus Multi A	10W-40		X		2)
	BP Vanellus Agri	10W-40		X		2)
	BP Vanellus Multi A	15W-40		X		2)
	BP Vanellus Agri	15W-40	X			2)
BP Vanellus Max Extra	15W-40			X	2)	

Multi-grade oils – Category 2, SAE grades 10W-30, 10W-40, 15W-40 and 20W-40 for diesel engines

Manufacturer	Product/brand name	SAE viscosity class	TBN			Remarks
			8 to 10 mgKOH/g	10 to 12 mgKOH/g	>12 mgKOH/g	
Castrol Ltd.	Castrol CRB Multi 10W-40 CI-4/E7	10W-40	X			
	Castrol CRB Multi 15W-40 CI-4/E7	15W-40	X			2)
	Castrol CRB Turbo 15W-40 CH-4/E7	15W-40	X			2)
	Castrol CRB Turbomax 15W-40 CI-4/SL/E7	15W-40		X		2)
	Castrol Rivermax CRB 15W-40 CI-4/E7	15W-40		X		2)
	Castrol Rivermax RX+ 15W-40	15W-40	X			2)
	Castrol Vecton 15W-40 DH-1	15W-40			X	2)
	Castrol RX Diesel	15W-40	X			
	Castrol RX Diesel 15W-40 CI-4/E7	15W-40		X		2)
	Castrol Vecton	10W-40		X		
	Castrol Vecton 15W-40 CI-4/E7	15W-40		X		2)
	Castrol Vecton 15W-40 CI-4 Plus/SL/E7				X	2)
Cepsa	Cepsa Euromax SHPD	15W-40		X		2)
Cepsa Comercial Petroleo S.A.U.	Traction Max SAE 15W-40	15W-40		X		2)
Champion Chemicals N.V.	Champion New Energy	15W-40		X		2)
Chevron Lubricants (Caltex)	Delo SHP Multigrade	15W-40		X		
	Delo Gold Multigrade	15W-40	X			
	Delo Gold Ultra	15W-40		X		2)
	Delo Gold Ultra E	10W-40		X		
	Delo Gold Ultra E	15W-40	X			2)
	Delo 400 Multigrade	15W-40			X	2)
	OEC SAE 15W-40	15W-40		X		
Chevron Lubricants (Texaco)	Ursa Super TD	15W-40		X		2)
	Ursa Premium TDX	15W-40		X		2)
	Ursa Premium TDX Plus	15W-40		X		2)
	Ursa Heavy Duty	15W-40	X			
CPC Corporation, Taiwan	CPC Superfleet CG4 Motor Oil	15W-40	X			
Cubalub	Cubalub Extra Diesel MX	15W-40			X	2)
	Cubalub Extra Diesel	15W-40	X			
Delek	Delkol Super Diesel	15W-40	X			
Delek Industries Ltd.	Super Diesel	15W-40		X		
Dunwell Petro-Chemical Co., Ltd.	Apex Super Motor Oil SL/CI-4, 15W-40	15W-40		X		2)

TIM-ID: 0000019001 - 011

Multi-grade oils – Category 2, SAE grades 10W-30, 10W-40, 15W-40 and 20W-40 for diesel engines

Manufacturer	Product/brand name	SAE viscosity class	TBN			Remarks
			8 to 10 mgKOH/g	10 to 12 mgKOH/g	>12 mgKOH/g	
EKO A.B.E.E.	Eko Forza plus	15W-40	X			
Engen Petroleum Ltd.	Engen Dieselube 600 Super	15W-40	X			2)
	Engen Dieselube 700 Super	15W-40		X		2)
eni S.p.A.	eni i-Sigma super fleet	15W-40		X		
	eni i-Sigma performance E3	15W-40	X			
	eni i-Sigma performance E7	15W-40		X		2)
	eni i-Sigma performance E7	15W-40	X			2)
Euroiltec Industry Co., Ltd.	Casoku	15W-40	X			
Exol Lubricants Ltd.	Taurus Extreme M	15W-40	X			2)
	Taurus Extreme HST	15W-40		X		2)
Exxon Mobil Corporation	Mobilgard HSD 15W-40 CH-4	15W-40	X			
	Mobilgard HSD 15W-40 CI-4	15W-40		X		2)
	Mobilgard 1 SHC	20W-40			X	Approved for fast commercial vessels up to 1500 h, 396, 1163
	Mobil Delvac Super 1300 C	15W-40	X			
	Mobil Delvac Super 1400	15W-40	X			
	Mobil Delvac Modern 15W-40 Super Defense	15W-40	X			
	Mobil Delvac MX	15W-40			X	
	Mobil Delvac MX Extra	15W-40			X	
	Mobil Delvac Advanced City Logistics	15W-40	X			
Mobil Delvac Legend CH-4 15W-40 Heavy Duty	15W-40	X				
Finke Mineralölwerk GmbH	AVIATICON Turbo Super	15W-40	X			2)
Formosa Petrochemical Corporation	Formosa Marine Fleet XMT	15W-40	X			
Fuchs Lubrifiants France	Cofran Plura Super	15W-40		X		2)

Multi-grade oils – Category 2, SAE grades 10W-30, 10W-40, 15W-40 and 20W-40 for diesel engines						
Manufacturer	Product/brand name	SAE viscosity class	TBN			Remarks
			8 to 10 mgKOH/g	10 to 12 mgKOH/g	>12 mgKOH/g	
Fuchs Petrolub SE	Fuchs Max Way	15W-40		X		2)
	Pentotruck	15W-40		X		2)
	Fuchs Titan Formel Plus	15W-40		X		
	Fuchs Titan Truck	15W-40	X			2)
	Fuchs Titan Truck Plus	10W-30		X		
	Fuchs Titan Truck Plus	15W-40		X		2)
	Fuchs Titan Unimax Plus MC	10W-40		X		
	Fuchs Titan Unimax Ultra MC	10W-40		X		
	Fuchs Titan Universal HD	15W-40	X			
Gazpromneft Lubricants Ltd.	G-Profi MSI 10W-40	10W-40		X		
	G-Profi MSI 15W-40	15W-40		X		
	G-Profi MSH 15W-40	15W-40	X			
	G-Profi MSI Plus	15W-40		X		2)
	G-Profi PSE	15W-40		X		2)
	Gazpromneft Diesel Premium	10W-40		X		
	Gazpromneft Diesel Premium	15W-40	X			2)
German Mirror Lubricants and Greases Co. FZE	Mirr Turbo Plus Diesel Engine Oil API CI-4 SAE 10W-40	10W-40		X		
	Mirr Turbo Plus Diesel Engine Oil API CI-4 SAE 15W-40	15W-40	X			2)
	Mirr Turbo Diesel Engine Oil API CH-4 SAE 15W-40	15W-40	X			2)
Ginouves Georges SAS	York 849	15W-40		X		2)
GS Caltex India Private Limited	Kixx Dynamic Gold	15W-40		X		2)
GS Caltex Corporation	Kixx HD 1	10W-40		X		
	Kixx HD 1	15W-40		X		2)
Gulf Oil International	Gulf Super Duty VLE	15W-40	X			
	Gulf Supreme Duty LE	15W-40		X		
	Gulf Superfleet LE	10W-40		X		
	Gulf Superfleet LE	15W-40	X			2)
	Gulf Superfleet Supreme	10W-40		X		
	Gulf Superfleet Supreme	15W-40		X		2)
	Gulf Superfleet Plus	15W-40	X			
Gulf Western Oil, Australia	TOP DOG XDO	15W-40	X			2)

TIM-ID: 0000019001 - 011

Multi-grade oils – Category 2, SAE grades 10W-30, 10W-40, 15W-40 and 20W-40 for diesel engines

Manufacturer	Product/brand name	SAE viscosity class	TBN			Remarks
			8 to 10 mgKOH/g	10 to 12 mgKOH/g	>12 mgKOH/g	
Hafa France	Stradex 1800	10W-40		X		
Hessol Lubrication GmbH	Hessol Turbo Diesel	15W-40		X		2)
	Hessol Super Longlife	10W-40		X		
High Industrial Lubricants & Liquids Corporation (HILL)	Fastroil Force F300 Diesel	15W-40		X		2)
	Fastroil Force F500 Diesel	15W-40		X		2)
	Fastroil Force F700 Diesel Pro	10W-40		X		
Hitachi Construction Machinery CO., Ltd.	Hitachi Premium Orange	15-W40	X			
Huiles Berliet S.A.	RTO Maxima RD	15W-40	X			2)
	RTO Maxima RLD	15W-40		X		2)
Hyrax Oil Sdn Bhd	Ceypetco Enduro	15W-40		X		2)
	Hyrax Admiral 15W-40	15W-40	X			2)
INA Maziva Ltd.	INA Super Max	15W-40		X		2)
Indian Oil Corporation Limited	Servo Premium (N)	15W-40		X		
	Servo Premium (N) 15W-40	15W-40		X		2)
	Servo Pride Supreme XL	15W-40		X		2)
Ipiranga Produtos des Petróleo S.A.	Ipiranga Brutus Alta Performance	15W-40		X		2)
Kuwait National Lube Oil MfgCo (KNLOC)	Burgan Ultra Diesel CH-4	15W-40		X		2)
Kuwait Petroleum	Q8 T 750	15W-40	X			2)
	Q8 T 800	10W-40	X			2)
Kocak Petrol Ürünleri San	Speedol SHPD Tirot 15W-40	15W-40		X		
Liqui Moly GmbH	Liqui Moly Marine 4T Motor Oil	15W-40		X		2)
	Liqui Moly Touring High Tech SHPD	15W-40		X		2)
Lotos Oil	Turdus Powertec CI-4 15W-40	15W-40		X		2)
	Turdus Powertec 1000	15W-40		X		2)
LPC S.A.	Cyclon D Super	15W-40	X			
	Cyclon Granit Maximum	15W-40		X		2)
Lubricantes de América	Generac Aceite	15W-40		X		
	Lubral Nano Diesel	15W-40		X		
	Lubral Nano Diesel SAE 5W-40 API CI-4 Plus / SL	15W-40		X		2)
Lubrisa	Gulf Superfleet Supreme	15W-40		X		2)

Multi-grade oils – Category 2, SAE grades 10W-30, 10W-40, 15W-40 and 20W-40 for diesel engines						
Manufacturer	Product/brand name	SAE viscosity class	TBN			Remarks
			8 to 10 mgKOH/g	10 to 12 mgKOH/g	>12 mgKOH/g	
Lukoil Lubricants Europe Oy	Teboil Power Plus	15W-40	X			
	Tepoil Super HPD	15W-40		X		
	Tepoil Super HPD C	10W-40		X		
Mabanol GmbH & Co. KG	Mabanol Argon Fleet	15W-40	X			
Mega Lube Marketers cc.	Megalube Diesel Engine Oil	15W-40		X		
Modriča Oil Refinery	Maxima Turbo	15W-40		X		
MOL-LUB Kft..	MOL MK-9	15W-40		X		
	Mol Dynamic Super Diesel	15W-40	X			
	Mol Transit 10W-40	10W-40		X		
	Mol Transit 15W-40	15W-40		X	2)	
	Mol Dynamic Transit	15W-40		X	2)	
	MOL Super Diesel	15W-40	X			
Morris Lubricants Limited	Versimax HD4	15W-40		X	2)	
Motorex AG	Motorex Universal	10W-40		X		
Motor Oil, Hellas	EMO SHPD Plus	15W-40		X		
MPM International Oil Company B.V.	Motor Oil 15W-40 Super High Performance	15W-40		X	2)	
NetLube Iran	Max Turbo	15W-40		X	2)	
NSL OilChem Trading Pte Ltd	Liquid Gold D-Flo X4	15W-40		X	2)	
Oman Oil Marketing Company SAOG	Omanoil Maximo Super 15W40 CH-4	15W-40	X		2)	
Orlen Oil	Mogul Diesel DTT Extra	15W-40			X	2)
	Platinum Ultor	15W-40	X			2)
	Platinum Ultor Plus	15W-40			X	2)
OOO “LLK-International”	Lukoil Avantgarde Extra	15W-40	X			2)
	Lukoil Avantgarde Ultra	15W-40		X		
	Lukoil Avantgarde Ultra NP	15W-40		X		
	Lukoil Avantgarde Ultra Plus	10W-40		X		
Oryx Energies	Enduro 600	15W-40		X		
Panolin AG	Panolin Universal SFE	10W-40		X		
	Panolin Diesel Synth	10W-40		X		
PDVSA CA	PDV Ultradiesel	15W-40		X	2)	
Petrobras Distribuidora S.A.	Lubrax Nautica Diesel	15W-40		X	2)	
PetroChina Lubricant Company	Tianwei CH-4 15W-40 diesel engine	15W-40	X			2)
Petrogulf Oil Manufacturing LLC	Paramount Extreme Action 15W40 CI-4	15W-40		X		2)

TIN-ID: 0000019001 - 011

Multi-grade oils – Category 2, SAE grades 10W-30, 10W-40, 15W-40 and 20W-40 for diesel engines

Manufacturer	Product/brand name	SAE viscosity class	TBN			Remarks
			8 to 10 mgKOH/g	10 to 12 mgKOH/g	>12 mgKOH/g	
Petrogal, S.A.	Galp Galaxia LD star	15W-40		X		
Petrol Ofisi A.Ş	Petrol Ofisi Maximus Turbo Diesel Extra	15W-40		X		2)
Petron Corporation	Petron Rev-x Premium Multi Grade	15W-40		X		2)
Petronas Lubricants International	Petronas Urania 3000	15W-40		X		2)
	Urania 3000 LS 10W30	10W30	X			
	Petronas Urania LD7	15W-40		X		
Petromin Oils Company	Petromin Turbomaster XD	15W-40		X		2)
	Petromin Turbomaster XD 15W40 CI-4	15W-40		X		2)
Phillips 66 Lubricants	Conoco Hydroclear Power D	15W-40			X	
Prista Oil Holding EAD	Prista Turbo Diesel	15W-40	X			
	Pro Auto HDEO E7 15W-40	15W-40		X		2)
PT Pertamina Lubricants	Meditran SX	15W-40		X		2)
	Meditran SX Plus	15W-40		X		
PTT Oil and Retail Business Public Company Limited	Navita Plus	15W-40		X		2)
PTT Public Limited	Navita Plus SAE 15W-40	15W-40	X			
Puma Energy S.A.	Puma HD Plus	15W-40		X		2)
Puma Lubricants	Puma Power Motor Oil	15W-40		X		2)
Qatar Lubricants Company Ltd.	QALCO Topaz HMF	15W-40	X			
Qingdao Copton Technology Co., LTD.	Copton CH-4 Diesel Engine Oil	15W-40	X			
Raloy Lubricantes, S.S. de C.V.	Raloy Diesel Power	15W-40		X		2)
Raj Petro Specialities P Ltd.	Zoomol Rforce 3 100 RF1	15W-40	X			2)
	Zoomol Rforce 3 100 RF4	15W-40		X		2)
RAMOIL SPA	DUGLAS OIL SUPER LIFE 15W-40 SHPDO	15W-40		X		2)
Ravensberger Schmierstoffvertrieb GmbH	RAVENOL Expert SHPD	10W-40		X		
	RAVENOL Turbo Plus SHPD	15W-40		X		
	RAVENOL Mineralöl Turbo Plus SHPD	15W-40	X			2)
Repsol Lubricantes y Especialidades, S.A.	Repsol Diesel Turbo THPD	15W-40			X	2)
	Repsol Diesel Super Turbo	15W-40		X		2)
	Repsol Diesel Super Turbo SHPD	15W-40	X			2)
	Repsol Neptuno S-Turbomar	15W-40	X			2)

Multi-grade oils – Category 2, SAE grades 10W-30, 10W-40, 15W-40 and 20W-40 for diesel engines						
Manufacturer	Product/brand name	SAE viscosity class	TBN			Remarks
			8 to 10 mgKOH/g	10 to 12 mgKOH/g	>12 mgKOH/g	
RN-Lubricants, LLC	Rosneft Revolux D2	15W-40	X			
	Rosneft Revolux D3	15W-40		X		2)
	Rosneft Revolux D5	15W-40		X		
ROWE Mineralölwerk GmbH	ROWE Hightec Formula GT SAE 10W-40 HC	10W-40		X		
	ROWE Hightec Turbo HD 15W-40 Plus	15W-40		X		2)
S.A.E.L.	Gulf Gulfleet Long Road	15W-40	X			
Shell International Petroleum Company	Shell Rimula MV	15W-40			X	2)
	Shell Rimula R3 MV	15W-40	X			2)
	Shell Rimula R3 X	15W-40		X		2)
	Shell Rimula R4	15W-40		X		2)
	Shell Rimula R4 Multi	15W-40		X		2)
	Shell Rimula R4 Plus	15W-40		X		2)
	Shell Rimula R4 X	15W-40		X		2)
	Shell Rimula RT4	15W-40		X		2)
	Shell Rimula RT4 X	15W-40		X		2)
	Shell Rimula T3	15W-40		X		2)
	Shell Rimula T4	15W-40		X		2)
	Shell Rimula X	15W-40		X		
	Shell Rotella T2	15W-40		X		
	Shell Rotella T Multigrade	15W-40		X		2)
	Shell Sirius	15W-40		X		2)
	Eicher Premium Plus Diesel Engine Oil	15W-40		X		2)
Singapore Petroleum Company Limited	SDM 900 SAE 15W40	15W-40		X		
Sinopec Lubricant Co., Ltd.	Sinopec Tulux T500	15W-40		X		2)
SK Lubricants Co. Ltd.	ZIC X5000 10W-40	10W-40		X		
	ZIC X5000	15W-40	X			2)
	ZIC X7000 CI-4 10W-40	10W-40		X		
	ZIC X7000 CI-4	15W-40	X			2)

TIM-ID: 0000019001 - 011

Multi-grade oils – Category 2, SAE grades 10W-30, 10W-40, 15W-40 and 20W-40 for diesel engines

Manufacturer	Product/brand name	SAE viscosity class	TBN			Remarks
			8 to 10 mgKOH/g	10 to 12 mgKOH/g	>12 mgKOH/g	
SRS Schmierstoff Vertrieb GmbH	SRS Motorenöl O-236	15W-40	X			2) Enhanced corrosion protection
	SRS Multi-Rekord top	15W-40		X		2)
	SRS Multi Rekord plus	15W-40	X			
	SRS Turbo Rekord	15W-40	X			2)
	SRS Turbo Rekord NG	15W-40		X		2)
	SRS Cargolub TFE	15W-40		X		
	SRS Cargolub TFX	10W-40		X		
Tesla Technoproducts FZE	Denebola Saheli Ultra XS 1120	15W-40		X		2)
Top 1 Oil Products Company	Top 1 Transport	15W-40		X		2)
Total Lubrifiants	Total Caprano TDI	15W-40		X		2)
	Total Disola W	15W-40		X		
	Hitachi Genuine Engine Oil 15W40 DH-1	15W-40		X		2)
UMW Grantt International Sdn Bhd	GRANTT QUASAR SAE 15W-40 API CI-4	15W-40		X		2)
Unil Opal	Medos 700	15W-40			X	2)
Valvoline EMEA	All-Fleet Extra SAE 15W-40	15W-40	X			2)
	All-Fleet Plus	15W-40	X			2)
	NextGen All-Fleet extra	15W-40		X		2)
	Premium Blue Classic	15W-40		X		2)
	Valvoline All-Fleet Extra	15W-40		X		2)
	Valvoline Premium Blue 7800	15W-40		X		
Veedol International Limited	VEEDOL DIESEL STAR EXTRA 15W-40	15W-40		X		2)
Viscolube	Revivoil - Re Refined High-Tech HD Motoroil	15W-40	X			2)
Viva Energy Australia	Penske Power Systems Premium	15W-40	X			2)
Wolf Oil Corporation NV.	Wolf Vitaltech 15W40	15W-40		X		2)
Wunsch Öle GmbH	Wunsch Rekord TLM-TU 10W-40	10W-40		X		
YPF ZA.	Extravida XV 200	15W40		X		2)

Table 72:

7.1.7 Multi-grade oils – Category 2.1 (Low SAPS oils), SAE grades 0W-30, 10W-30, 5W-40, 10W-40 and 15W-40 for diesel engines

For details and special features, see chapter “Lubricants for four-stroke cycle engines” (→ Page 7)

Important

²⁾ Engine oils marked ²⁾ are also approved for Series 60 engines

Multi-grade oils

Multi-grade oils – Category 2.1 (Low SAPS oils), SAE grades 0W-30, 10W-30, 5W-40, 10W-40 and 15W-40 for diesel engines						
Manufacturer	Product/brand name	SAE viscosity class	TBN			Remarks
			8 to 10 mgKOH/g	10 to 12 mgKOH/g	>12 mgKOH/g	
Rolls-Royce Solutions America Inc.	Power Guard® SAE 15W-40 Off-Highway Heavy Duty	15W-40	X			5 gallons: 800 133 55 gallons: 800 134 IBC: 800 135 Available from Rolls-Royce Solutions America Inc. ²⁾
BP p.l.c.	BP Vanellus Eco	15W-40	X			²⁾
Calumet Branded Products LLC	Royal Purple Duralec Super 15W-40	15W-40	X			²⁾
	Bel-Ray Hyperion Synthetic Blend	10W-30	X			
	Bel-Ray Hyperion Elite Synthetic 5W-40 CK-4	5W-40		X		
Canroyal Oil Lubricants / Dist.	Canroyal Synthetic Diesel Engine Oil	15W-40	X			²⁾
Castrol Ltd.	Castrol CRB Mining 15W-40	15W-40	X			²⁾
	Castrol CRB Mining 15W-40 CK-4	15W-40	X			²⁾
	Castrol CRB Turbo G4 15W-40	15W-40	X			²⁾
	Castrol Hypuron	10W-30		X		
	Castrol RX Super 15W-40 CJ-4/E9	15W-40	X			²⁾
	Castrol Vecton 15W-40 CK-4/E9	15W-40	X			²⁾
Champion Chemicals N.V.	Champion OEM specific 15W40 MS	15W-40	X			²⁾
Chevron Lubricants (Chevron)	Delo 400 LE	15W-40	X			²⁾ Also approved for Series 4000-04 T
	Delo 400 LE Synthetic	5W-40		X		
	Delo 400 MGX	15W-40	X			²⁾
	Delo 400 SDE	15W-40	X			²⁾
	Delo 400 XLE	10W-30		X		
	Delo 400 XLE	15W-40		X		²⁾
	Delo 400 XSP	5W-40		X		

TIM-ID: 0000019003 - 009

Multi-grade oils – Category 2.1 (Low SAPS oils), SAE grades 0W-30, 10W-30, 5W-40, 10W-40 and 15W-40 for diesel engines

Manufacturer	Product/brand name	SAE viscosity class	TBN			Remarks
			8 to 10 mgKOH/g	10 to 12 mgKOH/g	>12 mgKOH/g	
Chevron Lubricants (Texaco)	Ursa Ultra LE	15W-40	X			2)
ExxonMobil Corporation	Mobil Delvac 1 ESP	0W-30	X			
	Mobil Delvac 1 ESP	5W-40		X		
	Mobil Delvac Extreme	15W-40		X		
	Mobil Fleet	15W-40	X			2)
	Mobil Delvac HDEO	15W-40	X			2)
	Mobil Delvac Modern 15W-40 Advanced Protection V1	15W-40		X		2)
	Mobil Delvac Modern 15W-40 Complete Protection	15W-40	X			2)
	Mobil Delvac Ultra 5W-40 Ultimate Protection V1	5W-40		X		
eni S.P.A.	eni i-Sigma top MS	15W-40	X			2)
Finke Mineralölwerke GmbH	AVIATICON Turbo LA Plus	10W-40	X			2)
	AVIATICON Turbo Super Plus	15W-40	X			2)
Fuchs Petrolub SE	Fuchs Titan Cargo	10W-40	X			
	Fuchs Titan Cargo	10W-30	X			
	Fuchs Titan Cargo	15W-40	X			2)
	PENTOTRUCK PRO SAE 15W-40	15W-40	X			2)
Gulf Oil International	Gulf Supreme Duty XLE	15W-40	X			2)
	Gulf Supreme Duty XLE	10W-30	X			
Hitachi Construction Machinery Co, Ltd.	Hitachi Genuine Engine Oil 10W-40 DH-2	10W-40	X			
Kuwait Petroleum	Q8 Formula Truck 7000 FE	10W-30	X			
	Q8 T 760	10W-30	X			
Liqui Moly GmbH	Liqui Moly Top Tec Truck 4650	10W-30	X			
	Liqui Moly Truck Nachfüll-Öl 10W-30	10W-30	X			
Lotos Oil	Turdus Powertec 1100	15W-40	X			2)
Morris Lubricants	Versimax HD6	15W-40	X			2)
MPM International Oil Company B.V.	Motor Oil 15W-40 Extra High Performance	15W-40	X			2)
OOO "LLK-International"	Lukoil Avantgarde Professional LA	10W-30	X			
	Lukoil Avantgarde Professional LA	10W-40	X			
	Lukoil Avantgarde Professional LA	15W-40	X			2)
Panolin AG	Panolin Universal LA-X	15W-40	X			2)

Multi-grade oils – Category 2.1 (Low SAPS oils), SAE grades 0W-30, 10W-30, 5W-40, 10W-40 and 15W-40 for diesel engines

Manufacturer	Product/brand name	SAE viscosity class	TBN			Remarks
			8 to 10 mgKOH/g	10 to 12 mgKOH/g	>12 mgKOH/g	
Pennzoil Products	Pennzoil Long-Life Gold	15W-40	X			2)
Petro-Canada	Duron HP	15W-40	X			2)
	Duron HP	15W-40	X			2)
Petronas Lubricants, Italy	Petronas Urania 3000 LS	15W-40	X			2)
Phillips 66 Lubricants	Fleet Supreme EC	15W-40	X			2) Also approved for Series 4000-04 C
	Guardol ECT	15W-40	X			2)
	Kenndall Super-D XA	15W-40	X			2)
Prolube Lubricants	Prolube Ultraplus	15W-40	X			2)
Repsol Lubricantes Y Especialidades, S.A.	Repsol Diesel Turbo THPD Mid Saps	15W-40	X			2)
RN-Lubricants LLC	Rosneft Revolux D7	15W-40	X			2)
Shell International Petroleum Company	Shell Rimula Super	15W-40		X		2)
	Shell Rimula RT4L	15W-40		X		2)
	Shell Rotella T	15W-40		X		2)
	Shell Rotella T3	15W-40		X		2)
	Shell Rotella T3 Fleet	15W-40	X			2)
	Shell Rotella T5	10W-30	X			
	Shell Rotella T5	10W-40	X			
	Shell Rotella T6	5W-40		X		
	Shell Rimula K4	15W-40	X			2)
	Shell Rimula K6	15W-40	X			2)
	Shell Rimula K8	10W-30	X			
	Shell Rimula K8	10W-40	X			
	Shell Rimula R5 LE	10W-30	X			
	Shell Rimula R5 LE	10W-40	X			
	Shell Rotella T Triple Protection	15W-40		X		
	Shell Rotella T4 Triple Protection	15W-40	X			2)
	Shell Rimula R4 MV	15W-40	X			2)
	Shell Rimula R4 L	15W-40	X			2)
SINOPEC Lubricant Co., Ltd.	Sinopec Tulux T700	15W-40	X			2)

TIM-ID: 000.0019003 - 009

Multi-grade oils – Category 2.1 (Low SAPS oils), SAE grades 0W-30, 10W-30, 5W-40, 10W-40 and 15W-40 for diesel engines

Manufacturer	Product/brand name	SAE viscosity class	TBN			Remarks
			8 to 10 mgKOH/g	10 to 12 mgKOH/g	>12 mgKOH/g	
SRS Schmierstoff Vertrieb GmbH	SRS Turbo Rekord plus	15W-40	X			2)
	SRS Turbo Rekord plus FE	10W-40	X			
	SRS Turbo Rekord ultra V	10W-30	X			
Total Lubrifiants	Total Rubia Works 2000	10W-40	X			
	Total Rubia Works 4000	10W-40	X			
	Total Rubia Works 4000	15W-40	X			2)
	Total Rubia Works 4000 FE	10W-30	X			
	Total Star Max FE	10W-30	X			
	Total Rubia Works 2000 FE 10W-30	10W-30	X			
Trinidad & Tobago National Petroleum Marketing Company Ltd. (NPMC)	Ultra Duty 15W-40 Engine Oil	15W-40	X			2)
Valvoline EMEA	Valvoline All Fleet Extra LE SAE 15W-40	15W-40	X			2)
	All-Fleet Extra LE NTI	15W-40	X			2)
	Valvoline All Fleet Superior LE	10W-30	X			
	Valvoline All Fleet Superior LE	15W-40	X			2)
	Premium Blue 8100 15W-40	15W-40	X			2)
Valvoline LLC	Premium Blue 8600 ES	10W-30		X		
	Premium Blue 8600 ES	15W-40		X		2)
Valvoline USA	All Fleet Plus	15W-40	X			2)
Veedol International Limited	VEEDOL MAX-PRO SPECIAL LSP 15W-40	15W-40	X			2)
Verco International	April Superpro RXL 1 Gold Plus	15W-40	X			2)
Wolf Oil Corporation N.V.	Wolf Officialtech 15W40 MS	15W-40	X			2)

Table 73:

7.1.8 Series-based usability of engine oils of oil categories 3 and 3.1 (low SAPS oils)

Series	Oil category 3 Multi-grade oils	Oil category 3.1 (low SAPS oils) Multi-grade oils	Remarks
S60	restricted ¹⁾	restricted ²⁾	¹⁾ = only 15W-40 and min. API CH-4 ²⁾ = only 15W-40 and API CJ-4
099	yes	yes	
183	yes	yes	
396	yes	yes	
538	yes	yes	
595	yes	yes	
956	yes	no	
956TB31/ 32 Nuclear power station, emergency power	Shell Rimula R6 MS 10W-40 Shell Rimula R6 M 10W-40	no	
956TB33 Nuclear power station, emergency power (E=12)	Shell Rimula R6 MS 10W-40 Shell Rimula R6 M 10W-40	no	
956TB34 Nuclear power station, emergency power	Shell Rimula R6 MS 10W-40 Shell Rimula R6 M 10W-40	no	
1163-01 Marine	yes	yes	
1163-02 Marine	yes	yes	
1163-02TB32/ Nuclear power station, emergency power	Shell Rimula R6 MS 10W-40 Shell Rimula R6 M 10W-40	no	
1163-03 Marine	yes	yes	
1163-04 Marine	yes	yes	
2000 Mx2 / Mx3 / Mx4	yes	yes	
2000Cx6 / Gx6 / Gx7 / Mx6 / Sx6	yes	yes	
2000Cx0 / Cx1 / Cx2	yes	yes	
2000Gx5	yes	yes	
2000Mx0 / Mx1	yes	yes	
2000M41A IMO III	no	yes	
2000Mx7	no	yes	
2000Px2	yes	yes	
2000Sx0 / Sx1 / Sx2	yes	yes	
4000-00	yes	yes	

Series	Oil category 3 Multi-grade oils	Oil category 3.1 (low SAPS oils) Multi-grade oils	Remarks
4000-01	yes	yes	
4000-02	yes	yes	
4000-03G / S / P / C / R	yes	yes	
4000-03Gx3F / Gx3G / Gx3H	yes	yes	
4000M23F - M63L	yes ³⁾	yes	³⁾ = Not permitted for operation with SCR systems (Selective Catalytic Reduction)
4000-03M53B / M73-M93L / N43S / N83	yes ⁴⁾	yes	⁴⁾ = Not permitted for operation with SCR systems (Selective Catalytic Reduction)
4000-03M73- M93L IMO II SCR ready	yes	yes	
4000-03M73- M93L IMO III	no	yes	
4000-03R63x	yes	yes	
12V4000U83	yes	yes	
4000-04 B	yes	yes	
4000-04 /- 05 C	yes	yes	Only 5W-40, 10W-40, 15W-40
4000-04 G	yes	yes	
4000-04 M	yes	yes	
4000-04 R54	yes	yes	Only 5W-40, 10W-40, 15W-40
4000-04 R64/74/84	no	yes	Only 5W-40, 10W-40, 15W-40
4000-04 / -05 T	yes	yes	Only 5W-40, 10W-40, 15W-40
4000-05 G	no	yes	
4000-05 M	yes ⁵⁾	yes	⁵⁾ = Not permitted for operation with SCR systems (Selective Catalytic Reduction)
4000-05 M IMO II	yes	yes	
4000-05 M IMO III	no	yes	
20V4000M53B IMO III	no	yes	
8V4000M63 IMO III	no	yes	
8000	restricted ⁶⁾	restricted ⁶⁾	⁶⁾ = only named engine oils

Table 74:

yes = approved

no = not approved

7.1.9 Multi-grade oils – Category 3, SAE grades 5W-30, 5W-40, 10W-40 and 15W-40 for diesel engines

For details and special features, see chapter “Lubricants for four-stroke cycle engines” (→ Page 7)

Multi-grade oils

Multi-grade oils – Category 3, SAE grades 5W-30, 5W-40, 10W-40 and 15W-40 for diesel engines						
Manufacturer	Brand name	SAE viscosity class	TBN			Remarks
			8 to 10 mgKOH/g	10 to 12 mgKOH/g	>12 mgKOH/g	
Addinol Lube Oil GmbH	Addinol Commercial 1040 E4	10W-40		X		
	Addinol Ultra Truck MD 0538	5W-30			X	
	Addinol Super Truck MD 1049	10W-40			X	
Aral AG	Aral Mega Turboral	10W-40			X	
	Aral Mega Turboral 10W-40	10W-40			X	
	Aral Super Turboral	5W-30			X	
	Aral Super Turboral 5W-30	5W-30			X	
Aramco Lubricants and Retail Company	Orizon HD vA	10W-40		X		
Atak Madeni Yağ Pas.San. Tic. Aş	Alpet Turbot FE	10W-40			X	
	Alpet Turbot MMS	10W-40			X	
Avia AG	Avia Turbosynth HT-E	10W-40			X	
	Avia Turbosynth HT-U	5W-30			X	
Avista Oil Deutschland GmbH	Avista pure EVO E4	10W-40			X	
	Avista pure EVO SWE	5W-30			X	
	Avista pure EVO SWE	10W-40			X	
Bahrain Petroleum Company B.S.C.	Frontier Turbo LDX	10W-40			X	
BayWa AG	Tectrol Super Truck 530	5W-30			X	
	Tectrol Super Truck 1040	10W-40		X		
BP p.l.c.	BP Energol IC-MT 10W-40	10W-40			X	
	BP Vanellus Max	5W-30			X	

Multi-grade oils – Category 3, SAE grades 5W-30, 5W-40, 10W-40 and 15W-40 for diesel engines

Manufacturer	Brand name	SAE viscosity class	TBN			Remarks
			8 to 10 mgKOH/g	10 to 12 mgKOH/g	>12 mgKOH/g	
Castrol Ltd.	Castrol CRB Turbomax 10W-40 E4/E7	10W-40			X	
	Castrol Enduron MT	10W-40			X	
	Castrol Enduron Plus	5W-30			X	
	Castrol Elixion HD	5W-30			X	
	Castrol Vecton 10W-40 E4/E7	10W-40			X	
	Castrol Vecton Long Drain	10W-40			X	
	Castrol Vecton Long Drain 5W-30 E4/E7	5W-30			X	
	Castrol Vecton Long Drain 10W-40 E7				X	
	Castrol Vecton Long Drain 10W-40 E4/E7	10W-40			X	
	Castrol Vecton 5W-30 Arctic	5W-30			X	
	Castrol Vecton Fuel Saver 5W-30	5W-30			X	
	Castrol Vecton Fuel Saver E7	5W-30			X	
Cepsa	Cepsa Eurotrans SHPD	5W-30			X	
	Cepsa Eurotrans SHPD	10W-40		X		
Cepsa Comercial Petroleo Limited	Traction Advanced LD	10W-40			X	
Champion Chemicals N.V.	Champion New Energy 10W40 Ultra	10W-40			X	
Chemicis Khavremianeh Kohan	Chemicis Excel Plus	10W-40			X	
Chevron Lubricants (Caltex)	Delo Gold Ultra T SAE 10W-40	10W-40			X	
	Delo XLD Multigrade	10W-40			X	
Chevron Lubricants (Texaco)	Ursa HD	10W-40			X	
	Ursa Premium FE	5W-30			X	
	Ursa Super	10W-40		X		
	Ursa Super TDX	10W-40			X	
	Ursa TDX	10W-40			X	
Deutsche Ölwerke Lubmin GmbH	AVENO HC PT Diesel	10W-40			X	
eni S.P.A.	eni i-Sigma top	10W-40			X	
	eni i-Sigma performance E4	10W-40			X	
Enoc Marketing LLC	Enoc Vulcan 770 SLD	10W-40		X		
	Enoc Vulcan SLD	10W-40			X	

TIN-ID: 0000019006 - 009

Multi-grade oils – Category 3, SAE grades 5W-30, 5W-40, 10W-40 and 15W-40 for diesel engines						
Manufacturer	Brand name	SAE viscosity class	TBN			Remarks
			8 to 10 mgKOH/g	10 to 12 mgKOH/g	>12 mgKOH/g	
Exxon Mobil Corporation	Mobil Delvac XHP Extra	10W-40			X	
	Mobil Delvac XHP Ultra 5W-30	5W-30			X	
	Mobil Delvac 1 SHC	5W-40			X	
	Mobil Delvac 1 SHC 5W-40	5W-40			X	
Exol Lubricants Ltd.	Taurus Extreme M3	10W-40			X	
Fabrika Maziva, FAM AD	Fenix Ultra Sint	10W-40			X	
Finke Mineralölwerk GmbH	AVIATICON Finko Truck LD	10W-40			X	
Fuchs Petrolub SE	Fuchs Titan Cargo SL	5W-30			X	
	Fuchs Titan Cargo MC	10W-40			X	
	Fuchs Max Way E4	10W-40				
	Fuchs Max Way Ultra	5W-30				
Fuchs Lubricants France S.A.	Cofran Marathon	10W-40			X	
Gazpromneft Lubricants Ltd,	G-Profi GTS	5W-30			X	
	G-Profi GT	10W-40			X	
	Gazprom Diesel Ultra Plus 10W-40	10W-40			X	
	Gazprom Diesel Ultra 15W-40	15W-40			X	
Gulf Oil International	Gulf Fleet Force synth.	5W-30			X	
	Gulf Superfleet ELD	10W-40			X	
	Gulf Superfleet XLD	10W-40			X	
	Gulf Superfleet Synth ELD	10W-40			X	
High Industrial Lubricants & Liquids Corporation	Fastroil Force Ultra High Performance Diesel (UHPD)	10W-40			X	
Huiles Berliet S.A.	RTO Extensia RXD ECO	5W-30			X	
Iranol Oil Co.	Iranol D40000-EIII	10W-40			X	
Kuwait Petroleum	Q8 T 860	10W-40		X		
	Q8 T 860 10W-40	10W-40			X	
	Q8 T 860 D	10W-40			X	
	Q8 T 860 S	10W-40			X	
	Q8 T 905	10W-40	X			
Lotos Oil	Turdus Powertec 3000	10W-40			X	
	Turdus Powertec Synthetic	5W-30			X	
Lukoil Lubricants Europe Oy	Teboil Super XLD-2	5W-30			X	
	Teboil Super XKD RW 10W-40	10W-40			X	
Meguin	Megol Motorenöl Super LL Dimo Premium	10W-40			X	

TIM-ID: 0000019006 - 009

Multi-grade oils – Category 3, SAE grades 5W-30, 5W-40, 10W-40 and 15W-40 for diesel engines

Manufacturer	Brand name	SAE viscosity class	TBN			Remarks
			8 to 10 mgKOH/g	10 to 12 mgKOH/g	>12 mgKOH/g	
MOL-LUB Kft	MOL Synt Diesel	10W-40		X		
	MOL Dynamic Synt Diesel E4	10W-40			X	
Motorex AG	MC Power Plus SAE 10W/40	10W-40			X	
Orlen Oil Sp.o.o.	Platinum Ultor Max	5W-30			X	
OOO LLK International	Lukoil Avantgarde Professional	5W-30			X	
	Lukoil Avantgarde Professional	10W-40			X	
	Lukoil Avantgarde Professional M5	10W-40			X	
	Lukoil Avantgarde Professional M6	5W-30			X	
	Lukoil Avantgarde Professional M6	10W-40			X	
	Lukoil Avantgarde Ultra M3	15W-40			X	
Panolin	Panolin Diesel HTE	10W-40			X	
Petrogal, S.A.	Galp Galaxia Extreme	5W-30		X		
	Galp Galaxia Ultra XHP	10W-40			X	
Petromin Oils Company	Petromin Turbo Master LD	10W-40			X	
Petronas Lubricants International	Urania 5000 10W-40				X	
	Urania 5000 F	5W-30			X	
PHI OIL GmbH	Motordor Silver 10W40	10W-40			X	
Raj Petro Specialities P Ltd.	Zooml Rforce 8200 RF1	10W-40			X	
Ramoil S.p.A.	Duglas Oil Ultra HC 10W-40 UHPDO	10W-40			X	
Ravensberger Schmierstoff Vertrieb GmbH	RAVENOL Super Performance Truck	5W-30			X	
	RAVENOL Performance Truck	10W-40			X	
Repsol Lubricantes y Especialidades S.A.	Repsol Turbo UHPD	10W-40			X	
	Repsol Diesel Turbo VHPD	5W-30			X	
	Repsol Diesel Turbo UHPD Urban	10W-40			X	
RN-Lubricants, LLC	Rosneft Revolux D4	10W-40			X	
	Rosneft Revolux D4 Plus	5W-30			X	
	Rosneft Revolux D4 Plus	10W-40			X	
SCT Vertriebs GmbH	Fanfaro TRD E4 UHPD	10W-40		X		
	Mannol TS-6 UHPD Eco	10W-40		X		
	Pemco Diesel G-6 Eco UHPD	10W-40		X		
Shell International Petroleum Company	Shell Rimula R5 M	10W-40			X	
	Shell Rimula R6 M	10W-40			X	
	Shell Rimula R6 ME	5W-30			X	
	Shell Rimula R6 MS	10W-40			X	
SK Lubricants Co.	ZIC X7000	5W-30			X	

Multi-grade oils – Category 3, SAE grades 5W-30, 5W-40, 10W-40 and 15W-40 for diesel engines						
Manufacturer	Brand name	SAE viscosity class	TBN			Remarks
			8 to 10 mgKOH/g	10 to 12 mgKOH/g	>12 mgKOH/g	
SRS Schmierstoff Vertrieb GmbH	SRS Cargolub TFF	10W-40			X	
	SRS Cargolub TFL	5W-30			X	
	SRS Cargolub TFG	10W-40			X	
	SRS Cargolub TFG plus	10W-40			X	
	SRS Cargolub TFG ultra	10W-40			X	
Tedex SA	Tedex Diesel Truck UHPD (S) Motor Oil	10W-40			X	
Total Lubrifiants	Cubalub ExtraDiesel	10W-40			X	
	Total Rubia TIR 9200 FE	5W-30			X	
Transnational Blenders B. V.	Engine Oil Super EHPD	10W-40			X	
Unil Opal	Unil Opal LCM 800	10W-40			X	
Valvoline EMEA	All Fleet Superior	10W-40			X	
	Profleet	10W-40			X	
	Valvoline All-Fleet Extreme NTI	10W-40		X		
Wolf Oil Corporation N.V.	Wolf Vitaltech 10W40 Ultra	10W-40			X	

Table 75:

7.1.10 Multi-grade oils – Category 3.1 (Low SAPS oils), SAE grades 5W-30, 10W-30 and 10W-40 for diesel engines

For details and special features, see chapter “Lubricants for four-stroke cycle engines” (→ Page 7)

Multi-grade oils

Multi-grade oils – Category 3.1 (Low SAPS oils), SAE grades 5W-30, 10W-30 and 10W-40 for diesel engines						
Manufacturer	Brand name	SAE viscosity class	TBN			Comments / material number
			8 to 10 mgKOH/g	10 to 12 mgKOH/g	>12 mgKOH/g	
Addinol Lube Oil	Addinol Extra Truck MD 1049 LE	10W-40	X			
Aral AG	Aral Mega Turboral LA	10W-40	X			
	Aral Super Turboral LA	5W-30	X			
Atak Madeni Yağ Pas.San.Tic.Aş	Alpet Turbot MMS	10W-40		X		
Avia AG	Avia Multi LSP Extra	10W-40		X		
Avista Oil Deutschland GmbH	Avista pure EVO GER	10W-40		X		
	Avista pure EVO CK-4	5W-30	X			
	Avista pure EVO CK-4	10W-30	X			
	Avista pure EVO CK-4	10W-40	X			
	Avista pure EVO PRIME 5W-30	5W-30		X		
BayWa AG	Tectrol Super Truck Plus XL 1040	10W-40	X			
Belgin Madeni Yağlar	BELGIN LUBEX ROBUS MASTER LA 10W-40	10W-40		X		
BP p.l.c.	BP Vanellus Max Drain Eco	10W-40			X	
	BP Vanellus Max Eco 10W-40	10W-40			X	
BVG Vertriebsgesellschaft AG	Alpha Advanced Eco-Efficiency low SAPS	10W-40	X			
Castrol Ltd.	Castrol Vecton Long Drain 10W-30 E6/E9	10W-30	X			
	Castrol Vecton Long Drain 10W-40 E6/E9	10W-40	X			
	Castrol Vecton Fuel Saver 5W-30 E6/E9	5W-30	X			
Cepsa Comercial Petroleo, S.A.U.	Cepsa Eurotech LS 10W40 Plus	10W-40			X	
	Traction Pro LS	10W-40			X	
Champion Chemicals N.V.	Champion OEM Specific 10W40 Ultra MS	10W-40		X		
	Champion OEM Specific 10W40 UHPD	10W-40			X	
Chevron Lubricants (Caltex)	Delo XLE Multigrade	10W-40	X			

Multi-grade oils – Category 3.1 (Low SAPS oils), SAE grades 5W-30, 10W-30 and 10W-40 for diesel engines						
Manufacturer	Brand name	SAE viscosity class	TBN			Comments / material number
			8 to 10 mgKOH/g	10 to 12 mgKOH/g	>12 mgKOH/g	
Chevron Lubricants (Chevron)	Delo 400 RDE	10W-30	X			
	Delo 400 RDS	10W-40	X			
	Delo 400 XLE	15W-40	X			
	Delo 400 XLE HD	5W-30			X	
	Delo 400 XLE HD	10W-40			X	
	Delo 400 XLE SYN-HD	10W-40			X	
	Delo 400 XLE Synthetic	5W-30	X			
	Delo 400 LE Synthetic	5W-30	X			
	Delo 400 XSP	5W-30	X			
	Delo 400 XSP-SD	5W-30	X			
Chevron Lubricants (Texaco)	Ursa Ultra X	10W-30	X			
CONDAT Lubrifiants	Vicam Planet 10W40	10W-40			X	
Deutsche Ölwerke Lubmin GmbH	AVENO Universal UHPD	10W-40				
De Oliebron B.V.	Tor Turbosynth LSP Plus	10W-40			X	
Ellis Enterprises B.V.	Valvoline Profleet LA	5W-30	X			
	Profleet LA	5W-30	X			
eni S.p.a.	eni i-Sigma top MS	10W-40	X			
Enoc Marketing L.L.C.	Enoc Vulkan Green	10W-40			X	
Exol Lubricants Ltd.	Taurus Euro	10W-40	X			
Exxon Mobil Corporation	Mobil Delvac 1 ESP	5W-30	X			
	Mobil Delvac 1 LE	5W-30	X			
	Mobil Delvac 1 LE	5W-30			X	
	Mobil Delvac HD	10W-40	X			
	Mobil Delvac XHP ESP	10W-40			X	
	Mobil Delvac XHP ESP M	10W-40			X	
	Mobil Delvac XHP ESP S	10W-40			X	
	Mobil Delvac XHP LE	10W-40			X	55 gallons: 800141
	Mobil Delvac XHP Ultra LE	5W-30	X			
Finke Mineralölwerk GmbH	AVIATICON Finko Super Truck LA Plus	10W-40	X			
Fuchs Petrolub SE	Titan Cargo Maxx	5W-30			X	
	Titan Cargo Maxx	10W-40			X	Enhanced corrosion protection
	Fuchs Titan Cargo EU6	5W-30	X			
	Fuchs Titan Cargo LA	5W-30	X			
	PENTOTRUCK ULTRA SAE 10W-30	10W-30	X			

TIN-ID: 000019019 - 011

Multi-grade oils – Category 3.1 (Low SAPS oils), SAE grades 5W-30, 10W-30 and 10W-40 for diesel engines

Manufacturer	Brand name	SAE viscosity class	TBN			Comments / material number
			8 to 10 mgKOH/g	10 to 12 mgKOH/g	>12 mgKOH/g	
Gazpromneft Lubricants Ltd.	G-Profi GT LA	10W-40			X	
Gulf Oil International	Gulf Superfleet ULE	10W-40	X			Enhanced corrosion protection
	Gulf Superfleet Synth ULE	5W-30	X			
	Gulf Superfleet XLE	10W-30	X			
	Gulf Superfleet XLE	10W-40	X			
	Gulf Superfleet Synth XLE	10W-30		X		
	Gulf Superfleet Synth XLE	10W-40	X			
	Gulf Superfleet Universal	5W-30			X	
	Gulf Superfleet Universal	10W-40			X	
Helios Lubeoil	Helios Premium KMXX 10W-40	10W-40	X			
Huiles Berliet S.A.	RTO Extensia FP	10W-40	X			
Igol	PRO 200 X	10W-40	X			
INA Maziva d.o.o.	INA Super 2009 5W-30	5W-30	X			
	INA Super 2009	10W-40			X	
Kuwait Petroleum R&T	Q8 905	10W-40	X			
	Q8 T 904	10W-40		X		
	Q8 T 904 FE	10W-30	X			
	Q8 T 905	10W-40	X			
	Q8 T 910	5W-30	X			
	Q8 Formula Truck 8500	10W-40	X			
	Q8 Formula Truck 8500 FE	10W-30	X			
	Q8 Formula Truck 8700 FE	5W-30	X			
	Q8 Formula Truck 8900 FE	5W-30	X			
LLK finland Oy	Teboil Super XLD-2	5W-30			X	
Meguin GmbH & Co. KG	megol Motorenoel Low Saps	10W-40		X		
MOL-LUB Ltd.	MOL Dynamic Mistral XT5W-30	5W-30	X			
	MOL Dynamic Mistral 10W-40	10W-40	X			
Morris Lubricants	Ring Free Ultra	10W-40		X		
	Fendt Power Grade 10W-40	10W-40		X		
	Versimax HD8	10W-40	X			
Motorex AG	Motorex Focus QTM	10W-40	X			
	Motorex / York Focus QTM	10W-40	X			
	Motorex / York Nexus FE SAE 5W-30	5W30			X	
	Motorex Nexus FE SAE 5W-30	5W30	X			

Multi-grade oils – Category 3.1 (Low SAPS oils), SAE grades 5W-30, 10W-30 and 10W-40 for diesel engines						
Manufacturer	Brand name	SAE viscosity class	TBN			Comments / material number
			8 to 10 mgKOH/g	10 to 12 mgKOH/g	>12 mgKOH/g	
MPM International Oil Company B.V.	Motor Oil 10w-40 Premium Synthetic Ultra High Performance Diesel	10W-40		X		
Neste Markkinointi Oy Lubricants	Neste Turbo+ LSA 5W-30	5W-30	X			
Oel-Brack AG	Midland maxtra	10W-40		X		
OMV Petrol Ofisi A.Ş	Maximus HD-E	5W-30	X			
OOO LLK International	Lukoil Avantgarde CNG	10W-40	X			
	Lukoil Avantgarde Professional LE	5W-30			X	
	Lukoil Avantgarde Professional LE	10W-40			X	
	Lukoil Avantgarde Professional LS	5W-30	X			
	Lukoil Avantgarde Professional LS	10W-40			X	
	Lukoil Avantgarde Professional LS5	5W-30	X			
	Lukoil Avantgarde Professional LS5	10W-40	X			
	Lukoil Avantgarde Professional XLE	5W-30			X	
	Lukoil Avantgarde Professional XLE	10W-40			X	
Orlen Oil	Platinum Ultor Complete	10W-40	X			
	Platinum Ultor Optimo	10W-30	X			
	Platinum Ultor Progress	10W-40		X		
	Mogul Diesel L-SAPS	10W-40		X		
Oscar Lubricants LLC	Oscar Zircon Novus	10W-40	X			
Panolin	Panolin Diesel Synth EU-4	10W-40	X			
	Panolin Ecomot	5W-30		X		
	Panolin Ecomot	10W-30	X			
	Panolin Ecomot	10W-40	X			
Petro-Canada Lubricants Inc.	Duron SHP E6	10W-40		X		
	Duron UHP 5W30	5W-30	X			
	Duron UHP E6	5W-30			X	
	Duron UHP E6	10W-40			X	
	Duron UHP E6 10W40	10W-40	X			
Petrogal, S.A.	Galp Galaxia Ultra LS	10W-40	X			
Petrolube Lubricants	Euromax	10W-40		X		

TİM ID: 0000019019 - 011

Multi-grade oils – Category 3.1 (Low SAPS oils), SAE grades 5W-30, 10W-30 and 10W-40 for diesel engines

Manufacturer	Brand name	SAE viscosity class	TBN			Comments / material number
			8 to 10 mgKOH/g	10 to 12 mgKOH/g	>12 mgKOH/g	
Petronas Lubricants International	Petronas Urania 5000 E	5W-30			X	
	Petronas Urania 5000 E	10W-40			X	
	Petronas Urania 5000 LS-FX	5W-30		X		
	Petronas Urania 5000 LSF 5W-30	5W-30	X			
	Petronas Urania 5000 LS 10W-40	10W-40	X			
	Petronas Urania FE LS	5W-30			X	
	Petronas Urania Ecotech	10W-40			X	
PHI OIL GmbH	Motodor LSP Gold 5W30	5W-30			X	
	Motodor LSP Silver	10W-40		X		
Prista Oil Ad	Prista UHPD	10W-40	X			
Ravensberger Schmierölvertrieb GmbH	Ravenol Euro VI Truck	10W-40	X			
	Ravenol Euro VI Truck SAE 10W-40	10W-40		X		
Repsol Lubricantes y Especialidades, S.A.	Repsol Diesel Turbo UHPD MID SAPS	10W-40	X			
	Repsol DieselTurbo VHPD Mid Saps	5W-30		X		
RN-Lubricants LLC	Rosneft Revolux D6	10W-40		X		
	Rosneft Revolux D6 Plus	5W-30			X	
	Rosneft Revolux D6 Plus	10W-40			X	
Rowe Mineralölwerk GmbH	Rowe Hightec Truckstar SAE 10W-40 HC-LA	10W-40		X		
Shell International Petroleum Company	Shell Fleet Pro CK-4	5W-30		X		
	Shell Rimula K10	10W-40			X	Enhanced corrosion protection
	Shell Rimula R6 LM	10W-40	X			Enhanced corrosion protection
	Shell Rimula R6 LME	5W-30		X		
	Shell Rimula R6 LME Plus	5W-30		X		
	Shell Rimula Ultra	5W-30			X	
	Shell Sirius S6 LM	10W-40			X	

Multi-grade oils – Category 3.1 (Low SAPS oils), SAE grades 5W-30, 10W-30 and 10W-40 for diesel engines						
Manufacturer	Brand name	SAE viscosity class	TBN			Comments / material number
			8 to 10 mgKOH/g	10 to 12 mgKOH/g	>12 mgKOH/g	
SRS Schmierstoff Vertrieb GmbH	SRS Antikorrol MLA	10W-40		X		Enhanced corrosion protection
	SRS Cargolub TLA	10W-40	X			
	SRS Cargolub TLA plus	10W-40		X		
	SRS Cargolub TLS	5W-30			X	
	SRS Cargolub TLS plus	5W-30		X		
	SRS Cargolub TLS top	5W-30	X			
	SRS Turbo Diesel LA	10W-40	X			
	SRS Cargolub low-friction engine oil LA	10W-40		X		
	SRS Turbo-Rekord top FE	10W-40		X		
	SRS Turbo-Rekord ultra FE	10W-40	X			
Total Lubrifiants	Total Rubia TIR 8900	10W-40	X			
	Total Rubia Works 2500	10W-40	X			
	Total Rubia Works 3000	10W-40		X		
	Total Rubia Works 3000 FE	5W-30			X	
Valvoline EMEA	Valvoline ProFleet LS	5W-30			X	
	Valvoline ProFleet LS	10W-40	X			
	ProFleet LS NTI	10W-40	X			
Veedol International Limited	VEEDOL MARATRON EXTRA LSP 10W-40	10W-40		X		
Wibo Schmierstoffe GmbH	Wibokraft Ultra AF 10W40	10W-40		X		
Wolf Oil Corporation N.V.	Wolf Officialtech 10W40 Ultra MS	10W-40		X		
	Wolf Officialtech 10W40 UHPD	10W-40			X	

Table 76:

7.2 Engine Oils for Two-Cycle Engines

7.2.1 Series-based usability for two-cycle engine oils

Series	Two-cycle engine oil API CF-2			Comments
	Single-grade oils SAE 40	Single-grade oils SAE 50	Multigrade oils 15W-40	
S 53	yes	restricted ¹	restricted ¹	¹ only short term at low temperatures ² at coolant outlet temp. > 94 °C
S 71	yes	restricted ¹	restricted ²	
S 92	yes	restricted ¹	restricted ²	
S 149	yes ²	yes	no	

Table 77:

7.2.2 Engine oils for two-stroke cycle engines

If the engine oils listed here are not available, two-stroke cycle engine oils may be used, provided they comply with the requirements listed in the table (Engine oil requirements for two-stroke cycle engines, (→ Page 19)).

Other two-stroke cycle engine oils

Manufacturer	Product name	SAE grade & oil category	Comments / material number
Rolls-Royce Solutions America Inc. America	Power Guard® Heavy-duty Diesel Engine Oil for Detroit Diesel 2-Cycle (4X1G) SAE 40	40, API CF-2	4X1 gallons: 23512701
	Power Guard® Heavy-duty Diesel Engine Oil for Detroit Diesel 2-Cycle SAE 40	40, API CF-2	5 gallons: 23512734 55 gallons: 23512702 IBC: 23512739
Chevron	Ursa Extra Duty SAE 40	40	
	Ursa Extra Duty SAE 50	50	
ExxonMobil	Exxon XD-3 Monogrades SAE 40	40	
	Mobile Delvac 1240	40	
	Mobile Delvac 1250	50	
Lukoil Marine Lubricants	Lukoil Navigo DD40	40	
	Lukoil Navigo DD40 Ultra	40	
Motorex AG	Motorex Extra SAE 40	40	
Panolin	Extra Diesel DD SAE 40	40	
Shell International Petroleum Company	Shell Rotella DD+40	40	

Table 78:

7.3 Lubricating Greases

7.3.1 Lubricating greases for general applications

For details and special features, see chapter "Lubricating greases" (→ Page 18)

Manufacturer	Brand name	Notes
Aral AG	Mehrzweckfett Arallub HL2	
BP p.l.c.	Energrease LS2	
Castrol Ltd.	Spheerol AP2	
Chevron	Multifak EP2	
SRS Schmierstoff Vertrieb GmbH	SRS Wiolub LFK2	
Shell Deutschland GmbH	Shell Gadus S2 V220 2	
Total	Total Multis EP2	
Veedol International	Multipurpose	

Table 79:

8 Approved Coolants

8.1 Series- and application-based usability of coolant additives

All details are based on the coolant circuit on the engine side, no allowance is made for external add-on components.

For details and special features, see “General” (→ Page 22) and “Unsuitable materials in the coolant circuit” (→ Page 24) in the chapter “Coolants”.

Important

- In the case of an engine coolant circuit with no light metal elements but with add-on components containing light metal (e.g. external cooling system), the coolant approvals for cooling systems containing light metal shall apply. If you have any doubts about a coolant application, consult your contact at Rolls-Royce Solutions.
- The maximum admissible antifreeze content for Series 2000, model types 00 to 07 in marine applications is limited to 40% by volume.
- For Series 4000C01 to C03 and 4000R01 to R03 propylene glycol based coolants, only the 40% ready mixture is approved for use.

Any deviant special agreements between the customer and Rolls-Royce Solutions GmbH remain valid.

mtu four-stroke cycle engines

X = approved

- = not approved

Series	Applica- tion	Cooling system contain- ing light metals	Emul- sions See chap- ter 8.2	Coolant with- out antifreeze See chapter		Antifreeze See chapter				Remarks
				8.3	8.4	8.5	8.6	8.9.1	8.9.2	
099	Marine	yes	-	X	-	X ¹⁾	-	-	-	¹⁾ not per- mitted at seawater tempera- ture > 20 °C !
183	Marine	yes	-	X	-	X ²⁾	-	-	-	²⁾ not per- mitted at seawater tempera- ture > 20 °C !
183	Rail		-	X	-	X	-	-	-	
396	Marine	yes	-	X	-	X ³⁾	-	X ³⁾	-	³⁾ not per- mitted at seawater tempera- ture > 20 °C !

Series	Applica- tion	Cooling system contain- ing light metals	Emul- sions See chap- ter 8.2	Coolant with- out antifreeze See chapter		Antifreeze See chapter				Remarks
				8.3	8.4	8.5	8.6	8.9.1	8.9.2	
396TB	Marine	yes	-	X	-	X ⁴⁾	-	X ⁴⁾	-	⁴⁾ not per- mitted at seawater tempera- ture > 20 °C !
	Genset	yes	-	X	-	X	-	X	-	
	Rail	yes	-	X	-	X	-	X	-	
396TC	Marine	yes	-	X	-	X ⁵⁾	-	X ⁵⁾	-	⁵⁾ not per- mitted at seawater tempera- ture > 20 °C !
	Genset	yes	-	X	-	X	-	X	-	
	C&I	yes	-	X	-	X	-	X	-	
	Rail	yes	-	X	-	X	-	X	-	
396TE	Marine	yes	-	X	-	X ⁶⁾	-	X ⁶⁾	-	⁶⁾ not per- mitted at seawater tempera- ture > 20 °C !
	Genset	yes	-	X	-	X	-	X	-	
	C&I	yes	-	X	-	X	-	X	-	
	Rail	yes	-	X	-	X	-	X	-	
538	Marine	yes	X	-	-	-	-	-	-	
595	Marine	yes	X	-	-	-	-	-	-	
956-01/ 956-02	Marine	yes	X	X	-	-	-	-	-	Heat reten- tion system
	Genset	yes	X	X	-	X	-	X	-	

Series	Applica- tion	Cooling system contain- ing light metals	Emul- sions See chap- ter 8.2	Coolant with- out antifreeze See chapter		Antifreeze See chapter				Remarks
				8.3	8.4	8.5	8.6	8.9.1	8.9.2	
20V 956TB33	Genset ⁷⁾	yes	X	-	-	-	-	-	-	⁷⁾ up to year of manufac- ture end of 2008, in acc. with identifica- tion plate
	Genset ⁸⁾	yes	-	X	-	X	-	X	-	⁸⁾ from year of manu- facture 2009, in acc. with identifica- tion plate
12V/16V 956TB33	Genset	yes	-	X	-	X	-	X	-	
956TB34	Genset	yes	-	X	-	X	-	X	-	
1163-02	Marine	yes	X	X	-	-	-	-	-	
	Genset	yes	X	X	-	X	-	X	-	
1163-03	Marine	yes	X	X ⁹⁾	-	-	-	-	-	When re- commis- sioning / returning to opera- tion, only water-solu- ble corro- sion inhibi- tor is per- mitted with approval as per chap. 8.3 ⁹⁾ for prod- ucts, see information in chap. 8.3
1163-04	Marine	yes	-	X ¹⁰⁾	-	-	-	-	-	¹⁰⁾ for prod- ucts, see information in chap. 8.3

Series	Applica- tion	Cooling system contain- ing light metals	Emul- sions See chap- ter 8.2	Coolant with- out antifreeze See chapter		Antifreeze See chapter				Remarks
				8.3	8.4	8.5	8.6	8.9.1	8.9.2	
2000 (incl. model type 07)	Marine	yes	-	X	-	X ^{11, 12)}	-	X ^{11, 12)}	-	¹¹⁾ not per- mitted at seawater tempera- ture > 25 °C if a heat ex- changer is installed on the engine ¹²⁾ max. ad- missible antifreeze content limited to 40% by vol- ume
2000 (incl. model type 06)	Genset	yes	-	X	-	X	-	X	-	
	C&I	no	-	-	X	-	X	X	X	
	Oil&Gas (S-en- gines)	no	-	-	X	-	X	X	-	
	Oil&Gas (P-en- gines)	yes	-	X	-	X	-	X	-	
4000-00/ 4000-01	Marine	yes	-	X	-	X ¹³⁾	-	X	-	¹³⁾ not per- mitted at seawater tempera- ture > 25 °C if a heat ex- changer is installed on the engine
4000-01/ 4000-02/ 4000-03/ 4000-04/ 4000-05	Genset	no	-	-	X	-	X ¹⁴⁾	X	X	¹⁴⁾ for prod- ucts, see information in chap. 8.6
4000-01/ 4000-02/ 4000-03	C&I	no	-	-	X	-	X	X	X ¹⁵⁾	¹⁵⁾ only a 40% ready mixture may be used.

TIM-ID: 0000034439 - 008

Series	Applica- tion	Cooling system contain- ing light metals	Emul- sions See chap- ter 8.2	Coolant with- out antifreeze See chapter		Antifreeze See chapter				Remarks
				8.3	8.4	8.5	8.6	8.9.1	8.9.2	
4000-01/ 4000-02/ 4000-03	Rail	no	-	-	X	-	X	X	X ¹⁶⁾	In the case of engines with no light metal components but with an external cooling system containing light metal, the coolant approvals for cooling systems containing light metal shall apply. ¹⁶⁾ only a 40% ready mixture may be used.
4000-01	Oil&Gas	Yes: P11, P61, P81, P91	-	X	-	X	-	X	-	
4000-02/ 4000-03	Oil&Gas	no	-	-	X	-	X	X	X	
4000-00	Rail	yes	-	X	-	X	-	X	-	
4000-03	Marine	no	-	-	X	-	X ¹⁷⁾	X ¹⁷⁾	X ¹⁷⁾	¹⁷⁾ not permitted at seawater temperature > 25 °C if a heat exchanger is installed on the engine
4000-U83	Submar- ine	yes	-	X	-	X ¹⁸⁾	-	X ¹⁸⁾	-	¹⁸⁾ not permitted at seawater temperature > 25 °C if a heat exchanger is installed on the engine

Series	Applica- tion	Cooling system contain- ing light metals	Emul- sions See chap- ter 8.2	Coolant with- out antifreeze See chapter		Antifreeze See chapter				Remarks
				8.3	8.4	8.5	8.6	8.9.1	8.9.2	
4000-04	Rail	no	-	-	-	-	X ¹⁹⁾	X	-	In the case of engines with no light metal components but with an external cooling system containing light metal, the coolant approvals for cooling systems containing light metal shall apply. ¹⁹⁾ for products, see information in chapter 8.6
4000-04 4000-05	Oil & Gas	no	-	-	-	-	X ²⁰⁾	X	-	²⁰⁾ for products, see information in chapter 8.6
	C&I	no	-	-	-	-	X ²¹⁾	X	-	²¹⁾ for products, see information in chapter 8.6

Series	Applica- tion	Cooling system contain- ing light metals	Emul- sions See chap- ter 8.2	Coolant with- out antifreeze See chapter		Antifreeze See chapter				Remarks
				8.3	8.4	8.5	8.6	8.9.1	8.9.2	
4000-04 4000-05	Marine	no	-	-	X	-	X ^{22, 23)}	X ²²⁾	-	²²⁾ not per- mitted at seawater tempera- ture > 25 °C if a heat ex- changer is installed on the engine ²³⁾ for prod- ucts, see information in chapter 8.6
8000	Marine	yes	-	X	-	-	-	-	-	

Table 80:

Detroit Diesel four-stroke cycle and two-stroke cycle engines

X = approved

- = not approved

Series	Applica- tion	Cooling system contain- ing light metals	Emul- sions See chap- ter 8.2	Coolant without anti- freeze See chapter		Antifreeze See chapter		Remarks
				8.7.1/ 8.7.2	8.8.1/ 8.8.2	8.7.3/ 8.7.4	8.8.3/ 8.8.4	
S60	Marine		-	X	-	X	-	Four- stroke cy- cle en- gines
S53	Marine C&I Genset	no	-	-	X	-	X	Two- stroke cy- cle en- gines
S71		no	-	-	X	-	X	Two- stroke cy- cle en- gines
S92		no	-	-	X	-	X	Two- stroke cy- cle en- gines
S149		no	-	-	X	-	X	Two- stroke cy- cle en- gines

Table 81:

8.2 Emulsifiable corrosion-inhibiting oils

For details and special features, see chapter on “Coolants”(→ Page 22)

Emulsifiable corrosion-inhibiting oils

Manufacturer	Brand name	Operating time Hour / Year	Comments / Material number
Houghton Deutschland GmbH	Oil 9 156	6000 / 1	X00056748 (barrel) X00056749 (canister)

Table 82:

8.3 Coolants without antifreeze for cooling systems containing light metal

8.3.1 Coolant without antifreeze – Concentrates for cooling systems containing light metal

For details and special features, see chapter on “Coolants” (→ Page 22)

Important

For Series 1163-03 and 1163-04 marine engines, only coolants marked with an asterisk * in the product/brand name may be used.

Coolants without antifreeze – concentrates

Manufacturer	Product/brand name	Inhibitors					Operating time Hours / Years	Comments / Material number
		Organic	Silicon	Nitrite	Phosphatized	Molybdate		
Rolls-Royce Solutions GmbH	Coolant CS100 Corrosion Inhibitor Concentrate*		X				6000 / 2	X00057233 (20 l) X00057232 (210 l) Also available from Rolls-Royce Solutions Asia Pte. Ltd.
Rolls-Royce Solutions America Inc.	Power Cool® Plus 6000 Concentrate*		X				6000 / 2	colored green 23533526 (1 gallon) 23533527 (5 gallons) Available from Rolls-Royce Solutions America Inc.
Arteco NV	Freecor NBI		X				6000 / 2	
BASF SE	Glyscorr G93 green*		X				6000 / 2	X00054105 (barrel) X00058062 (canister)
CCI Corporation	A 216	X				X	6000 / 2	
CCI Manufacturing IL Corporation	A 216	X				X	6000 / 2	X00051509 (208 l)
Chevron Corp.	Texcool A - 200		X				6000 / 2	
Detroit Diesel Corp.	Power Cool Plus 6000	X				X	6000 / 2	colored red
Drew Marine	Drewgard XTA*		X				6000 / 2	
ExxonMobil	Mobil Delvac Extended Life Corrosion Inhibitor	X				X	6000 / 2	
Old World Industries Inc.	Final Charge Extended Life Corrosion Inhibitor (A 216)	X				X	6000 / 2	
Valvoline	ZEREX G-93*		X				6000 / 2	
	OEM Advanced 93*		X				6000 / 2	
YORK SAS	York 719*		X				6000 / 2	

Table 83:

8.3.2 Coolant without antifreeze – Ready mixtures for cooling systems containing light metal

For details and special features, see chapter on “Coolants” (→ Page 22)

Important

For Series 1163-03 and 1163-04 marine engines, only coolants marked with an asterisk * in the product name may be used.

Coolant without antifreeze, ready mixtures

Manufacturer	Product name	Inhibitors					Operating time Hours / Years	Comments / Material number
		Organic	Silicon	Nitrite	Phosphatized	Molybdate		
Rolls-Royce Solutions GmbH	Coolant CS10/90 Corrosion Inhibitor Premix*		X				6000 / 2	X00069385 (20 l) X00069386 (210 l) (Sales region: Italy)

Table 84:

8.4 Coolants without antifreeze for cooling systems free of light metal

8.4.1 Coolants without antifreeze – Concentrates for cooling systems free of light metal

For details and special features, see chapter on “Coolants” (→ Page 22)

Coolants without antifreeze – concentrates

Manufacturer	Product/brand name	Inhibitors					Operating time Hours / Years	Comments / Material number
		Organic	Silicon	Nitrite	Phosphatized	Molybdate		
Rolls-Royce Solutions GmbH	Coolant CS100 Corrosion Inhibitor Concentrate		X				6000 / 2	X00057233 (20 l) X00057232 (210 l) Also available from Rolls-Royce Solutions Asia Pte. Ltd.
Rolls-Royce Solutions America Inc.	Power Cool®Plus 6000 Concentrate		X				6000 / 2	colored green 23533526 (1 gallon) 23533527 (5 gallons) Available from Rolls-Royce Solutions America Inc.
Arteco NV	Freecor NBI		X				6000 / 2	
	Havoline Extended Life Corrosion Inhibitor [EU Code 32765] (XLI)	X					6000 / 2	
BASF SE	Glyscorr G93 green		X				6000 / 2	X00054105 (barrel) X00058062 (canister)
CCI Corporation	A 216	X				X	6000 / 2	
CCI Manufacturing IL Corporation	A 216	X				X	6000 / 2	X00051509 (208 l)
Chevron Corp.	Texcool A – 200		X				6000 / 2	
Chevron Lubricants	Delo XLI Corrosion Inhibitor - Concentrate	X					6000 / 2	
Detroit Diesel Corp.	Power Cool Plus 2000		X	X			6000 / 2	
	Power Cool Plus 6000	X				X	6000 / 2	colored red
Drew Marine	Drewgard XTA		X				6000 / 2	
ExxonMobil	Mobil Delvac Extended Life Corrosion Inhibitor	X				X	6000 / 2	
Fleetguard	DCA-4L		X	X	X		2000 / 1	
ImproChem	COOL-18		X	X			6000 / 2	
Nalco Water An Ecolab Company	Alfloc™ 3477	X					6000 / 2	
	Nalcool® 2000		X	X			6000 / 2	
Old World Industries Inc.	Final Charge Extended Life Corrosion Inhibitor (A 216)	X				X	6000 / 2	

TIM-ID: 0000019146 - 009

Manufacturer	Product/brand name	Inhibitors					Operating time Hours / Years	Comments / Material number
		Organic	Silicon	Nitrite	Phosphatized	Molybdate		
Penray	Pencool 2000		X	X			6000 / 2	
PrixMax Australia Pty. Ltd.	PrixMax RCP	X					6000 / 2	
Total Lubrifiants	Total WT Supra	X					6000 / 2	
Valvoline	Zerex G-93		X				6000 / 2	
	OEM Advanced 93		X				6000 / 2	
YORK SAS	York 719		X				6000 / 2	

Table 85:

8.4.2 Coolant without antifreeze – Ready mixtures for cooling systems free of light metal

For details and special features, see chapter on “Coolants” (→ Page 22)

Coolant without antifreeze, ready mixtures

Manufacturer	Product/brand name	Inhibitors					Operating time Hours / Years	Comments / Material number
		Organic	Silicon	Nitrite	Phosphatized	Molybdate		
Rolls-Royce Solutions GmbH	Coolant CS 10/90 Corrosion Inhibitor Premix		X				6000 / 2	X00069385 (20 l) X00069386 (210 l) (Sales region: Italy)
Nalco Water An Ecolab Company	Alfloc™ 3443 (7 %)	X					6000 / 2	
PrixMax Australia Pty Ltd	PrixMax RCP Premix	X					6000 / 2	

Table 86:

8.5 Antifreezes for cooling systems containing light metal

8.5.1 Antifreeze - Concentrates for cooling systems containing light metal

For details and special features, see chapter on “Coolants” (→ Page 22)

Antifreeze concentrates

Manufacturer	Product/brand name	Inhibitors					Operating time Hours / Years	Comments / Material number
		Organic	Silicon	Nitrite	Phosphatized	Molybdate		
Rolls-Royce Solutions GmbH	Coolant AH100 Antifreeze Concentrate	X	X				9000 / 5	X00057231 (20 l) X00057230 (210 l) Also available from Rolls-Royce Solutions Asia Pte. Ltd.
Alliance Automotive Service GmbH	NAPA Premium Kühlerschutz N48	X	X				9000 / 5	
Avia AG	Antifreeze APN	X	X				9000 / 5	
	Antifreeze APN - S	X					9000 / 3	
BASF SE	Glysantin G05		X	X			9000 / 5	
	Glysantin G48 blue green	X	X				9000 / 5	X00058054 (25 l) X00058053 (210 l)
	Glysantin G30 pink	X					9000 / 3	X00058072 (canister) X00058071 (barrel)
BayWa AG	Tectrol Coolprotect	X	X				9000 / 5	
BP Lubricants	Aral Antifreeze Extra	X	X				9000 / 5	
Castrol	Castrol Radicool NF	X	X				9000 / 5	
CCI Corporation	L 415	X				X	9000 / 3	
Clariant	Genantin Super		X	X			9000 / 5	
Classic Schmierstoff GmbH + Co KG	Classic Kolda UE G48	X	X				9000 / 5	
Comma Oil & Chemicals Ltd.	Comma Xstream® G30® Antifreeze Coolant Concentrate	X					9000 / 3	
	Comma Xstream® G48® Antifreeze Coolant Concentrate	X	X				9000 / 5	
COPARTS Autoteile GmbH	CAR 1 Premium Longlife Kühlerschutz C48	X	X				9000 / 5	
Daimler Trucks North America	Alliance OAT Extended Life Coolant	X				X	9000 / 3	
Detroit Diesel Corp.	Power Cool Antifreeze		X	X			9000 / 3	
	Power Cool Plus Coolant	X				X	9000 / 3	
	Power Cool Diesel Engine Coolant		X	X			9000 / 3	

TIM-ID: 0000019149 - 012

Manufacturer	Product/brand name	Inhibitors					Operating time Hours / Years	Comments / Material number
		Organic	Silicon	Nitrite	Phosphatized	Molybdate		
Drew Marine	Drewgard ZX	X					9000 / 3	
ExxonMobil	Mobil Delvac Extended Life Coolant	X				X	9000 / 3	
	Mobil Antifreeze Advanced	X					9000 / 3	
	Mobil Antifreeze Extra	X	X				9000 / 5	
	Mobil Antifreeze Special		X	X			9000 / 5	
	Mobil Heavy Duty Coolant		X	X			9000 / 3	
	Mobil Mining Coolant		X	X			9000 / 3	
	Esso Antifreeze Advanced	X					9000 / 3	
	Esso Antifreeze Extra	X	X				9000 / 5	
Finke Mineralölwerk GmbH	AVIATICON Finkofreeze F30	X					9000 / 3	
	AVIATICON Finkofreeze F48	X	X				9000 / 5	
Fuchs Petrolub SE	Maintain Fricofin	X	X				9000 / 5	
	Maintain Fricofin G12 Plus	X					9000 / 3	X00058074 (canister) X00058073 (barrel)
INA Maziva Ltd.	INA Antifriz AI Super	X	X				9000 / 5	
Krafft S.L.U.	Refrigerante ACU 2300		X	X			9000 / 3	X00058075 (barrel)
Kuttenkeuler GmbH	Kuttenkeuler Antifreeze ANF KK48	X	X				9000 / 5	
	Glycostar®ST48	X	X				9000 / 5	
LLK-International (Lukoil Lubricants Co)	Lukoil Antifreeze HD G 12 K	X					9000 / 3	
Lukoil Lubricants Europe GmbH	Lukoil Coolant Plus	X	X				9000 / 5	
	Lukoil Coolant SF	X					9000 / 3	
Mitan Mineralöl GmbH	Alpine C30	X					9000 / 3	
	Alpine C48	X	X				9000 / 5	
MJL Bangladesh Ltd.	Omera Premium Coolant	X					9000 / 3	
MOFIN Deutschland GmbH & Co KG	MOFIN Kühlerschutz M48 Premium Protect	X	X				9000 / 5	
Motorex AG	Motorex Coolant G48	X	X				9000 / 5	
Nalco Water An Ecolab Company	Nalcool NF 48 C	X	X				9000 / 5	
Navistar Inc.	Fleetrite Nitrite-Free Extended Life Coolant	X				X	9000 / 3	

TIM-ID: 0000019149 - 012

Manufacturer	Product/brand name	Inhibitors					Operating time Hours / Years	Comments / Material number
		Organic	Silicon	Nitrite	Phosphatized	Molybdate		
Old World Industries Inc.	Blue Mountain Heavy Duty Extended Life Coolant	X				X	9000 / 3	
	Fleet Charge SCA Pre-charged Coolant / Anti-freeze		X	X			9000 / 3	
	Final Charge Global Extended Life Coolant Antifreeze	X				X	9000 / 3	
	Peak Heavy Duty Coolant		X	X			9000 / 3	
Panolin AG	Panolin Anti-Frost MT-325	X	X				9000 / 5	
Penske Power Systems	Power Cool - HB500 Coolant Concentrate	X	X				9000 / 3	
Raloy Lubricantes	Antifreeze Long Life NF-300 Concentrate	X	X				9000 / 5	
Recochem Inc.	HD Expert™ Endurance	X				X	9000 / 3	
	R542	X	X				9000 / 3	
SMB - Sotragal / Mont Blanc	Antigel Power Cooling Concentrate	X	X				9000 / 5	
Total Lubrifiants	Glacelf MDX	X	X				9000 / 5	
Valvoline	Zerex G-05		X	X			9000 / 5	
	Zerex G-48	X	X				9000 / 5	
	Zerex G-30	X					9000 / 3	
	OEM Advanced 05		X	X			9000 / 5	
	OEM Advanced 30	X					9000 / 3	
	OEM Advanced 48	X	X				9000 / 5	
Volvo Trucks	Road Choice Nitrite-Free OAT Extended Life Coolant	X				X	9000 / 3	
YORK SAS	York 716	X	X				9000 / 5	

Table 87:

8.5.2 Antifreeze – Ready mixtures for cooling systems containing light metals

For details and special features, see chapter on “Coolants” (→ Page 22)

Important

For model type 00 to 07 Series 2000 marine engines, only coolants marked with an asterisk * in the product/brand name may be used.

Ready mixtures for cooling systems containing light metals

Manufacturer	Product/brand name	Inhibitors					Operating time Hours / Years	Comments / Material number
		Organic	Silicon	Nitrite	Phosphatized	Molybdate		
Rolls-Royce Solutions GmbH	Coolant AH 35/65 Antifreeze Premix*	X	X				9000 / 5	X00069382 (20 l) X00069383 (210 l) X00069384 (1000 l) (Sales region: Italy)
	Coolant AH 40/60 Antifreeze Premix*	X	X				9000 / 5	X00070533 (20 l) X00070532 (1000 l) (Sales region: England, Spain)
	Coolant AH 50/50 Antifreeze Premix	X	X				9000 / 5	X00070528 (20 l) X00070530 (1000 l) (Sales region: England)
Rolls-Royce Solutions America Inc.	Power Cool® Universal 35/65 mix*	X	X				9000 / 5	800085 (5 gallons) 800086 (55 gallons)
	Power Cool® Universal 50/50 mix	X	X				9000 / 5	800071 (5 gallons) 800084 (55 gallons)
	Power Cool® Off-Highway Coolant 50/50 Premix		X	X			9000 / 5	23533531 (5 gallons) 23533532 (55 gallons)
Bantleon	Avilub Antifreeze Mix (50 %)	X	X				9000 / 5	X00049213 (210 l)
BayWa AG	Tectrol Coolprotect Mix 3000*	X					9000 / 3	Antifreeze protection down to -24 °C
Castrol	Castrol Radicool NF Premix (45%)	X	X				9000 / 5	
CCI Corporation	L 415 (50%)	X				X	9000 / 3	
Cepsa Comercial Petróleo S.A.U.	XTAR Super Coolant Hybrid NF 50%	X	X				9000 / 5	
Daimler Trucks North America	Alliance 50/50 Prediluted OAT Extended Life Coolant	X				X	9000 / 3	
Detroit Diesel Corp.	Power Cool Plus Prediluted Coolant (50/50)	X				X	9000 / 3	
	Power Cool Prediluted 50/50 Diesel Engine Coolant		X	X			9000 / 3	

TIM-ID: 0000019156 - 009

Manufacturer	Product/brand name	Inhibitors					Operating time Hours / Years	Comments / Material number
		Organic	Silicon	Nitrite	Phosphatized	Molybdate		
Exxon Mobil	Mobil Delvac Extended Life Prediluted Coolant (50/50)	X				X	9000 / 3	
	Mobile Heavy Duty 50/50 Prediluted Coolant		X	X			9000 / 3	
	Mobile Mining 50/50 Prediluted Coolant		X	X			9000 / 3	
Finke Mineralölwerk GmbH	AVIATICON Finkofreeze F48 RM 50/50	X	X				9000 / 5	
	AVIATICON Finkofreeze F30 RM 40:60 +*	X					9000 / 3	
LLK-International (Lukoil Lubricants Co)	Lukoil Antifreeze HD G 12 (50%)	X					9000 / 3	
Motorex AG	Motorex Coolant G48 ready to use (50/50)	X	X				9000 / 5	
Navistar Inc.	Fleetrite 50/50 Prediluted Nitrite-Free Life Coolant	X				X	9000 / 3	
Old World Industries Inc.	Blue Mountain Heavy Duty Extended Life Prediluted Coolant (50/50)	X				X	9000 / 3	
	Final Charge Global Extended Life Prediluted Coolant/ Antifreeze (50/50)	X				X	9000 / 3	
	Fleet Charge SCA Pre-charged 50/50 Prediluted Coolant		X	X			9000 / 3	
Penske Power Systems	Power Cool - HB500 Premix 50/50	X	X				9000 / 3	
Raloy Lubricantes	Antifreez Long Life NF-300 Ready-to-Use (50:50)	X	X				9000 / 5	
Recochem	HD Expert™ Endurance 50-50 Prediluted	X				X	9000 / 3	
SMB - Sotragal / Mont Blanc	L.R.-30 Power Cooling (44%)	X	X				9000 / 5	
	L.R.-38 Power Cooling (52%)	X	X				9000 / 5	
Tosol-Sintez	Glystantin Alu Protect G30 Ready Mix	X					9000 / 3	
	Glystantin Alu Protect Plus G48 Ready Mix	X	X				9000 / 5	
Total Lubrificants	Coolelf MDX -26 °C*	X	X				9000 / 5	
	Coolelf MDX -37 °C	X	X				9000 / 5	
Valentin Energie GmbH	Valentin Coolant Plus -25 °C Ready*	X					9000 / 3	

TIM-ID: 0000019156 - 009

Manufacturer	Product/brand name	Inhibitors					Operating time Hours / Years	Comments / Material number
		Organic	Silicon	Nitrite	Phosphatized	Molybdate		
Valvoline	Zerex G-05 50/50 Mix		X	X			9000 / 5	
	Zerex G-48 premix 50%	X	X				9000 / 5	
	OEM Advanced 48 premix 50%	X	X				9000 / 5	
Volvo Trucks	Road Choice 50/50 Prediluted Nitrite-Free OAT Extended Life Coolant	X				X	9000 / 3	
YPF S.A. Argentina	Kriox MTL50	X				X	9000 / 3	

Table 88:

8.6 Antifreezes for cooling systems free of light metal

8.6.1 Antifreeze - Concentrates for cooling systems free of light metal

For details and special features, see chapter on “Coolants” (→ Page 22)

Important

For Series 4000-04 (except genset) and 4000-05, only coolants marked with an asterisk * in the product/brand name may be used.

Antifreeze concentrates

Manufacturer	Product/brand name	Inhibitors					Operating time Hours / Years	Comments / Material number
		Organic	Silicon	Nitrite	Phosphatized	Molybdate		
Rolls-Royce Solutions GmbH	Coolant AH100* Antifreeze Concentrate	X	X				9000 / 5	X00057231 (20 l) X00057230 (210 l) Also available from Rolls-Royce Solutions Asia Pte. Ltd.
Alliance Automotive Service GmbH	NAPA Premium Kühlerschutz N48	X	X				9000 / 5	
Arteco NV	Havoline Extended Life Coolant XLC [EU Code 30379]	X					9000 / 3	
Avia AG	Antifreeze APN*	X	X				9000 / 5	
	Antifreeze APN - S*	X					9000 / 3	
	AVIA Coolant APN-S	X					9000 / 3	
BASF SE	Glysantin G05		X	X			9000 / 5	
	Glysantin G48 blue green*	X	X				9000 / 5	X00058054 (25 l) X00058053 (210 l)
	Glysantin G30 pink*	X					9000 / 3	X00058072 (canister) X00058071 (barrel)
BayWa AG	Tectrol Coolprotect*	X	X				9000 / 5	
BP Lubricants	ARAL Antifreeze Extra*	X	X				9000 / 5	
Caltex	Caltex Extended Life Coolant [AP Code 510614] (XLC)	X					9000 / 3	
Castrol	Castrol Radicool NF*	X	X				9000 / 5	
CCI Corporation	L415*	X				X	9000 / 3	
Chevron Corp.	Havoline Dexcool Extended Life Antifreeze [US Code 227994]	X					9000 / 3	
Chevron Lubricants	Delo XLC Antifreeze/Coolant-Concentrate	X					9000 / 3	
Clariant	Genantin Super		X	X			9000 / 3	

Manufacturer	Product/brand name	Inhibitors					Operating time Hours / Years	Comments / Material number
		Organic	Silicon	Nitrite	Phosphatized	Molybdate		
Classic Schmierstoff GmbH + Co. KG	Classic Kolda UE G48*	X	X				9000 / 5	
Comma Oil & Chemicals Ltd.	Comma Xstream® G30®* Antifreeze Coolant Concentrate	X					9000 / 3	
	Comma Xstream® G48®* Antifreeze Coolant Concentrate	X	X				9000 / 5	
COPARTS Autoteile GmbH	CAR1 Premium Longlife Kühlerschutz C48*	X	X				9000 / 5	
Daimler Trucks North America	Alliance OAT Extended Life Coolant*	X				X	9000 / 3	
Detroit Diesel Corp.	Power Cool Antifreeze		X	X			9000 / 3	
	Power Cool Plus Coolant*	X				X	9000 / 3	
	Power Cool Diesel Engine Coolant		X	X			9000 / 3	
Drew Marine	Drewgard ZX*	X					9000 / 3	
ExxonMobil	Mobil Delvac Extended Life Coolant*	X				X	9000 / 3	
	Mobil Antifreeze Advanced*	X					9000 / 3	
	Mobil Antifreeze Extra*	X	X				9000 / 5	
	Mobil Antifreeze Special		X	X			9000 / 5	
	Mobil Heavy Duty Coolant		X	X			9000 / 3	
	Mobil Mining Coolant		X	X			9000 / 3	
	Esso Antifreeze Advanced*	X					9000 / 3	
	Esso Antifreeze Extra*	X	X				9000 / 5	
Finke Mineralölwerk GmbH	AVIATICON Finkofreeze F30*	X					9000 / 3	
	AVIATICON Finkofreeze F48*	X	X				9000 / 5	
Fuchs Petrolub SE	Maintain Fricofin*	X	X				9000 / 5	
	Maintain Fricofin G12 Plus*	X					9000 / 3	X00058074 (canister) X00058073 (barrel)
	Maintain Fricofin HDD [Oilcode T-AF3-1]	X	X	X			9000 / 3	
	Maintain Fricofin LL	X					9000 / 3	
	Pentofrost HD [Oilcode T-AF3-1]	X	X	X			9000 / 3	
INA Maziva Ltd.	INA Antifriz AI Super*	X	X				9000 / 5	
Krafft S.L.U	Refrigerante ACU 2300		X	X			9000 / 3	X00058075 (barrel)

Manufacturer	Product/brand name	Inhibitors					Operating time Hours / Years	Comments / Material number
		Organic	Silicon	Nitrite	Phosphatized	Molybdate		
Kuttenkeuler GmbH	Kuttenkeuler Antifreeze ANF KK48*	X	X				9000 / 5	
	Glycostar® ST48*	X	X				9000 / 5	
Kuwait Petroleum Research & Technology BV	Q8 Mahler Cool	X					9000 / 3	
	Roloil Rol-ICE SNF	X					9000 / 3	
LLK-International (Lukoil Lubricants Co)	Lukoil Antifreeze HD G12 K*	X					9000 / 3	
Lukoil Lubricants Europe GmbH	Lukoil Coolant Plus*	X	X				9000 / 5	
	Lukoil Coolant SF*	X					9000 / 3	
Mitan Mineralöl GmbH	Alpine C30*	X					9000 / 3	
	Alpine C48*	X	X				9000 / 5	
MJL Bangladesh	Omera Premium Coolant*	X					9000 / 3	
MOFIN Deutschland GmbH & Co KG	MOFIN Kühlerschutz M48 Premium Protect*	X	X				9000 / 5	
MOL-Lub Kft.	EVOX Premium concentrate	X					9000 / 3	
Motorex AG	Motorex Coolant G48*	X	X				9000 / 5	
Nalco Water An Ecolab Company	Nalcool NF 48 C*	X	X				9000 / 5	
Navistar Inc.	Fleetrite Nitrite-Free Extended Life Coolant*	X				X	9000 / 3	
OAo Technoform	Cool Stream Premium C	X					9000 / 3	
Old World Industries Inc.	Blue Mountain Heavy Duty Extended Life Coolant*	X				X	9000 / 3	
	Fleetcharge SCA Pre-charged Coolant / Antifreeze		X	X			9000 / 3	
	Final Charge Global Extended Life Coolant Antifreeze*	X				X	9000 / 3	
	Peak Heavy Duty Coolant		X	X			9000 / 3	
Panolin AG	Panolin Anti-Frost MT-325*	X	X				9000 / 5	
Penske Power Systems	Power Cool - HB500	X	X				9000 / 3	
	Power Cool - HB800	X	X	X			9000 / 3	
Puma Energy International S.A.	Puma HD XLC Coolant	X					9000 / 3	
Raloy Lubricantes	Antifreeze Long Life NF-300 Concentrate*	X	X				9000 / 5	
Recochem Inc.	HD Expert™ Endurance*	X				X	9000 / 3	
	R542	X	X				9000 / 3	
	R824M	X	X	X			9000 / 3	
Shell	Shell HD Premium N		X	X			9000 / 3	

TIM-ID: 0000019158 - 009

Manufacturer	Product/brand name	Inhibitors					Operating time Hours / Years	Comments / Material number
		Organic	Silicon	Nitrite	Phosphatized	Molybdate		
SMB - Sotragal / Mont Blanc	Antigel Power Cooling Concentrate*	X	X				9000 / 5	
Total Lubrifiants	Glacelf Auto Supra	X					9000 / 3	
	Glacelf MDX*	X	X				9000 / 5	
	Glacelf Supra	X					9000 / 3	
Valvoline	Zerex G-05		X	X			9000 / 5	
	Zerex G-30*	X					9000 / 3	
	Zerex G-48*	X	X				9000 / 5	
	OEM Advanced 05		X	X			9000 / 5	
	OEM Advanced G 30*	X					9000 / 3	
	OEM Advanced G 48*	X	X				9000 / 5	
Volvo Trucks	Road Choice Nitrite-Free OAT Extended Life Coolant*	X				X	9000 / 3	
YORK SAS	York 716*	X	X				9000 / 5	

Table 89:

8.6.2 Antifreeze – Ready mixtures for cooling systems free of light metals

For details and special features, see chapter on “Coolants” (→ Page 22)

Important
For Series 4000-04 (except genset) and 4000-05, only coolants marked with an asterisk * in the product/brand name may be used.

Antifreeze, ready mixtures

Manufacturer	Brand name	Inhibitors					Operating time Hours / Years	Comments / Material number
		Organic	Silicon	Nitrite	Phosphatized	Molybdate		
Rolls-Royce Solutions GmbH	Coolant AH 35/65 Anti-freeze Premix*	X	X				9000 / 5	X00069382 (20 l) X00069383 (210 l) X00069384 (1000 l) (Sales region: Italy)
	Coolant AH 40/60 Anti-freeze Premix*	X	X				9000 / 5	X00070533 (20 l) X00070532 (1000 l) (Sales region: England, Spain)
	Coolant AH 50/50 Anti-freeze Premix*	X	X				9000 / 5	X00070528 (20 l) X00070530 (1000 l) (Sales region: England)
Rolls-Royce Solutions America Inc.	Power Cool® Universal 35/65 mix*	X	X				9000 / 5	800085 (5 gallons) 800086 (55 gallons)
	Power Cool® Universal 50/50 mix*	X	X				9000 / 5	800071 (5 gallons) 800084 (55 gallons)
	Power Cool® Off-Highway Coolant 50/50 Premix		X	X			9000 / 5	23533531 (5 gallons) 23533532 (55 gallons)
Arteco NV	Havoline Extended Life Coolant + B2 50/50 OF01 [EU Code 33073] (50 %)	X					9000 / 3	
	Havoline Extended Life Coolant + B2 40/60 OF01 [EU Code 33069] (40 %)	X					9000 / 3	
	Havoline Extended Life Coolant + B2 35/65 OF01 [EU Code 33074] (35 %)	X					9000 / 3	
Bantleon	Avilub Antifreeze Mix (50 %)*	X	X				9000 / 5	X00049213 (210 l)
BayWa AG	Tectrol Coolprotect Mix 3000*	X					9000 / 3	Antifreeze protection down to -24 °C
Caltex	Caltex Extended Life Coolant Pre-Mixed 50/50 [AP Code 510609] (50 %)	X					9000 / 3	
Castrol	Castrol Radicool NF Premix (45 %)*	X	X				9000 / 5	

TIM-ID: 0000019159 - 010

Manufacturer	Brand name	Inhibitors					Operating time Hours / Years	Comments / Material number
		Organic	Silicon	Nitrite	Phosphatized	Molybdate		
CCI Corporation	L 415 (50%)*	X				X	9000 / 3	
Cepsa Comercial Petróleo S.A.U.	Xtar Super Coolant Hybrid NF 50%*	X	X				9000 / 5	
Chevron Corp.	Havoline Dexcool Extended Life Prediluted 50/50 Antifreeze Coolant [US Code 227995]	X					9000 / 3	
Daimler Trucks North America	Alliance 50/50 Prediluted OAT Extended Life Coolant*	X				X	9000 / 3	
Detroit Diesel Corp.	Power Cool Plus Prediluted Coolant (50/50)*	X				X	9000 / 3	
	Power Cool Prediluted 50/50 Diesel Engine Coolant		X	X			9000 / 3	
ExxonMobil	Mobil Delvac Extended Life Prediluted Coolant (50/50)*	X				X	9000 / 3	
	Mobile Heavy Duty 50/50 Prediluted Coolant		X	X			9000 / 3	
	Mobile Mining 50/50 Prediluted Coolant		X	X			9000 / 3	
Finke Mineralölwerk GmbH	AVIATICON Finkofreeze F48 RM 50/50*	X	X				9000 / 5	
	AVIATICON Finkofreeze F30 RM 40:60 +*	X					9000 / 3	
Fuchs Petrolub SE	Maintain Fricofin HDD 50	X	X	X			9000 / 3	
	Maintain Fricofin HDD 50 [Oilcode T-AF3-2]	X	X	X			9000 / 3	
	Maintain Fricofin LL	X					9000 / 3	
Kuwait Petroleum Research & Technology BV	Q8 Mahler Cool premixed 4060	X					9000 / 3	
	Roloil Ro-ICE SNF 4060	X					9000 / 3	
LLK-International (Lukoil Lubricants Co)	Lukoil Antifreeze HD G12 (50%)*	X					9000 / 3	
Motorex AG	Motorex Coolant G48 ready to use (50/50)*	X	X				5000 / 5	
Navistar Inc.	Fleetrite 50/50 Prediluted Nitrite-Free Extended Life Coolant*	X				X	9000 / 3	

TIM-ID: 0000019159 - 010

Manufacturer	Brand name	Inhibitors					Operating time Hours / Years	Comments / Material number
		Organic	Silicon	Nitrite	Phosphatized	Molybdate		
Old World Industries Inc.	Blue Mountain Heavy Duty Extended Life Prediluted Coolant (50/50)*	X				X	9000 / 3	
	Final Charge Global Extended Life Prediluted Coolant / Antifreeze (50/50)*	X				X	9000 / 3	
	Fleet Charge SCA Pre-charged 50/50 Prediluted Coolant		X	X			9000 / 3	
Penske Power Systems	Power Cool - HB500 Premix 50/50	X	X				9000 / 3	
	Power Cool - HB800 Premix 50/50	X	X	X			9000 / 3	
Puma Energy International S.A.	Puma HD XLP Coolant	X					9000 / 3	50% premix
Raloy Lubricantes	Antifreeze Long Life NF-300 Ready-to-Use (50:50)*	X	X				9000 / 5	
Recochem	HD Expert™ Endurance 50-50 Prediluted*	X				X	9000 / 3	
SMB - Sotragal / Mont Blanc	L.R.-30 Power Cooling (44 %)*	X	X				9000 / 5	
	L.R.-38 Power Cooling (52%)*	X	X				9000 / 5	
Total Lubrificants	Coolelf MDX -26 °C*	X	X				9000 / 5	
	Coolelf MDX -37 °C	X	X				9000 / 5	
	Coolelf Supra (40%)	X					9000 / 3	
	Coolelf Supra GF NP (50 %)	X					9000 / 3	
Tosol-Sinzez	Glystantin Alu Protect/G30 Ready Mix*	X					9000 / 3	
	Glystantin Protect Plus/G48 Ready Mix*	X	X				9000 / 5	
Valentin Energie GmbH	Valentin Coolant Plus -25 °C Ready*	X					9000 / 3	
Valvoline	Zerex G-05 50/50 Mix		X	X			9000 / 5	
	Zerex G-48 premix 50%*	X	X				9000 / 5	
	OEM Advanced 48 premix 50%*	X	X				9000 / 5	
Volvo Trucks	Road Choice 50/50 Prediluted Nitrite-Free OAT Extended Life Coolant*	X				X	9000 / 3	
YPF S.A. Argentina	Kriox MTL50*	X				X	9000 / 3	

Table 90:

TIM-ID: 0000019159 - 010

8.7 Coolant Additives for Series 60 Engines

8.7.1 Coolant without antifreeze – Concentrates for Series 60 engines

For details and special features, see chapter on “Coolants” (→ Page 22)

Coolants without antifreeze – concentrates

Manufacturer	Product/brand name	Inhibitors					Operating time Hours / Years	Comments / Material number
		Organic	Silicon	Nitrite	Phosphatized	Molybdate		
Rolls-Royce Solutions GmbH	Coolant CS 100 Corrosion Inhibitor Concentrate	X					6000 / 2	X00057233 (20 l) X00057232 (210 l) Also available from Rolls-Royce Solutions Asia Pte. Ltd.
Rolls-Royce Solutions America Inc.	Power Cool®Plus 6000 Concentrate	X					6000 / 2	colored green 23533526 (1 gallon) 23533527 (5 gallons) Available from Rolls-Royce Solutions America Inc.
BASF SE	Glysacorr G93 green	X					6000 / 2	X00054105 (barrel) X00058062 (canister)
Drew Marine	Drewgard XTA	X					6000 / 2	
Valvoline	ZEREX G-93	X					6000 / 2	
	OEM Advanced 93	X					6000 / 2	
YORK SAS	York 719	X					6000 / 2	

Table 91:

8.7.2 Coolant without antifreeze – Ready mixtures for Series 60 engines

For details and special features, see chapter on “Coolants” (→ Page 22)

Coolant without antifreeze, ready mixtures

Manufacturer	Product name	Inhibitors					Operating time Hours / Years	Comments / Material number
		Organic	Silicone	Nitrite	Phosphatized	Molybdate		
Rolls-Royce Solutions GmbH	Coolant CS 10/90 Corrosion Inhibitor Premix		X				6000 / 2	X00069385 (20 l) X00069386 (210 l) Sales region: Italy

Table 92:

8.7.3 Antifreeze – Concentrates for Series 60 engines

For details and special features, see chapter on “Coolants” (→ Page 22)

Antifreeze concentrates

Manufacturer	Product/brand name	Inhibitors					Operating time Hours / Years	Comments / Material number
		Organic	Silicon	Nitrite	Phosphatized	Molybdate		
Rolls-Royce Solutions GmbH	Coolant AH100 Antifreeze Concentrate	X	X				9000 / 5	X00057231 (20 l) X00057230 (210 l) Also available from Rolls-Royce Solutions Asia Pte. Ltd.
Alliance Automotive Service GmbH	NAPA Premium Kühlerschutz N48	X	X				9000 / 5	
Avia AG	Antifreeze APN	X	X				9000 / 5	
	Antifreeze APN - S	X					9000 / 3	
BASF SE	Glysantin G05		X	X			9000 / 5	
	Glysantin G30 pink	X					9000 / 3	X00058072 (canister) X00058071 (barrel)
	Glysantin G48 blue green	X	X				9000 / 5	X00058054 (25 l) X00058053 (210 l)
BayWa AG	Tectrol Coolprotect	X	X				9000 / 5	
BP Lubricants	Aral Antifreeze Extra	X	X				9000 / 5	
Castrol	Castrol Radicool NF	X	X				9000 / 5	
CCI Corporation	L 415	X				X	9000 / 3	
Classic Schmierstoff GmbH + Co KG	Classic Kolda UE G48	X	X				9000 / 5	
Comma Oil & Chemicals Ltd.	Comma Xstream® G30® Antifreeze Coolant Concentrate	X					9000 / 3	
	Comma Xstream® G48® Antifreeze Coolant Concentrate	X	X				9000 / 5	
COPARTS Autoteile GmbH	CAR1 Premium Longlife Kühlerschutz C48	X	X				9000 / 5	
Daimler Trucks North America	Alliance OAT Extended Life Coolant	X				X	9000 / 3	
Detroit Diesel Corp.	Power Cool Antifreeze		X	X			9000 / 3	
	Power Cool Plus Coolant	X				X	9000 / 3	
	Power Cool Diesel Engine Coolant		X	X			9000 / 3	
Drew Marine	Drewgard ZX	X					9000 / 3	

TIM-ID: 0000019160 - 008

Manufacturer	Product/brand name	Inhibitors					Operating time Hours / Years	Comments / Material number
		Organic	Silicon	Nitrite	Phosphatized	Molybdate		
ExxonMobil	Mobil Delvac Extended Life Coolant	X				X	9000 / 3	
	Mobil Antifreeze Advanced	X					9000 / 3	
	Mobil Antifreeze Extra	X	X				9000 / 5	
	Mobil Antifreeze Special		X	X			9000 / 5	
	Mobil Heavy Duty Coolant		X	X			9000 / 3	
	Mobil Mining Coolant		X	X			9000 / 3	
	Esso Antifreeze Advanced	X					9000 / 3	
	Esso Antifreeze Extra	X	X				9000 / 5	
Finke Mineralölwerk GmbH	AVIATICON Finkofreeze F30	X					9000 / 3	
	AVIATICON Finkofreeze F48	X	X				9000 / 5	
Fuchs Petrolub SE	Maintain Fricofin	X	X				9000 / 5	
	Maintain Fricofin G 12 Plus	X					9000 / 3	X00058074 (canister) X00058073 (barrel)
INA Maziva Ltd.	INA Antifriz AI Super	X	X				9000 / 5	
Kuttenkeuler GmbH	Kuttenkeuler Antifreeze ANF KK 48	X	X				9000 / 5	
	Glycostar®ST 48	X	X				9000 / 5	
LLK-International (Lukoil Lubricants Co)	Lukoil Antifreeze HD G12 K	X					9000 / 3	
Lukoil Lubricants Europe GmbH	Lukoil Coolant Plus	X	X				9000 / 5	
	Lukoil Coolant SF	X					9000 / 3	
Mitan Mineralöl GmbH	Alpine C30	X					9000 / 3	
	Alpine C48	X	X				9000 / 5	
MJL Bangladesh Ltd.	Omera Premium Coolant	X					9000 / 3	
MOFIN Deutschland GmbH & Co KG	MOFIN Kühlerschutz M48 Premium Protect	X	X				9000 / 5	
Motorex AG	Motorex Coolant G48	X	X				9000 / 5	
Nalco Water An Ecolab Company	Nalcool NF 48 C	X	X				9000 / 5	
Navistar Inc.	Fleetrite Nitrite-Free Extended Life Coolant	X				X	9000 / 3	
Old World Industries Inc.	Blue Mountain Heavy Duty Extended Life Coolant	X				X	9000 / 3	
	Fleet Charge SCA Pre-charged Coolant / Antifreeze		X	X			9000 / 3	
	Final Charge Global Extended Life Coolant/Antifreeze	X				X	9000 / 3	
	Peak Heavy Duty Coolant		X	X			9000 / 3	

TIM-ID: 0000019160 - 008

Manufacturer	Product/brand name	Inhibitors					Operating time Hours / Years	Comments / Material number
		Organic	Silicon	Nitrite	Phosphatized	Molybdate		
Panolin AG	Panolin Anti-Frost MT-325	X	X				9000 / 5	
Penske Power Systems	Power - Cool HB500	X	X				9000 / 3	
Raloy Lubricantes	Antifreeze Long Life NF - 300 Concentrate	X	X				9000 / 5	
Recochem Inc.	HD Expert™ Endurance	X				X	9000 / 3	
	R 542	X	X				9000 / 3	
SMB - Sotagal / Mont Blanc	Antigel Power Cooling Concentrate	X	X				9000 / 5	
Total Lubrifiants	Glacelf MDX	X	X				9000 / 5	
Valvoline	Zerex G 05		X	X			9000 / 5	
	Zerex G-48	X	X				9000 / 5	
	Zerex G 30	X					9000 / 3	
	OEM Advanced 05		X	X			9000 / 5	
	OEM Advanced 30	X					9000 / 3	
	OEM Advanced 48	X	X				9000 / 5	
Volvo Trucks	Road Choice Nitrite-Free OAT Extended Life Coolant	X				X	9000 / 3	

Table 93:

8.7.4 Antifreeze – Ready mixtures for Series 60 engines

For details and special features, see chapter on “Coolants” (→ Page 22)

Antifreeze, ready mixtures

Manufacturer	Product/brand name	Organic Inhibitors					Operating time Hours / Years	Comments / Material number
		Organic	Silicon	Nitrite	Phosphatized	Molybdate		
Rolls-Royce Solutions GmbH	Coolant AH 35/65 Anti-freeze Premix	X	X				9000 / 5	X00069382 (20 l) X00069383 (210 l) X00069384 (1000 l) (Sales region: Italy)
	Coolant AH 40/60 Anti-freeze Premix	X	X				9000 / 5	X00070533 (20 l) X00070532 (1000 l) (Sales region: England, Spain)
	Coolant AH 50/50 Anti-freeze Premix	X	X				9000 / 5	X00070528 (20 l) X00070527 (1000 l) (Sales region: England)
Rolls-Royce Solutions America Inc.	Power Cool® Universal (35/65)	X	X				9000 / 5	800085 (5 gallons) 800086 (55 gallons)
	Power Cool® Universal (50/50)	X	X				9000 / 5	800069 (1 gallon) 800071 (5 gallons) 800084 (55 gallons)
	Power Cool® Off Highway 50/50		X	X			9000 / 5	23533530 (1 gallon) 23533531 (5 gallons) 23533532 (55 gallons)
Bantleon	Avilub Antifreeze Mix (50 %)	X	X				9000 / 5	X00049213 (210 l)
BayWa AG	Tectrol Coolprotect Mix 3000	X					9000 / 3	Antifreeze protection down to -24 °C
Castrol	Castrol Radicool NF Premix (45%)	X	X				9000 / 5	
CCI Corporation	L 415 (50%)	X				X	9000 / 3	
Cepsa Comercial Petróleo S.A.U.	XTAR Super Coolant Hybrid NF 50%	X	X				9000 / 5	
Daimler Trucks North America	Alliance 50/50 Prediluted OAT Extended Life Coolant	X				X	9000 / 3	
Detroit Diesel Corp.	Power Cool Plus Prediluted Coolant (50/50)	X				X	9000 / 3	
	Power Cool Prediluted 50/50 Diesel Engine Coolant		X	X			9000 / 3	

TIM-ID: 0000034533 - 008

Manufacturer	Product/brand name	Organic Inhibitors					Operating time Hours / Years	Comments / Material number
		Silicon	Nitrite	Phosphatized	Molybdate			
ExxonMobil	Mobil Delvac Extended Life Prediluted Coolant (50/50)	X				X	9000 / 3	
	Mobile Heavy Duty 50/50 Prediluted Coolant		X	X			9000 / 3	
	Mobile Mining 50/50 Prediluted Coolant		X	X			9000 / 3	
Finke Mineralölwerk GmbH	AVIATICON Finkofreeze F48 RM 50/50	X	X				9000 / 5	
	AVIATICON Finkofreeze F30 RM 40:60 +	X					9000 / 3	
LLK-International (Lukoil Lubricants Co)	Lukoil Antifreeze HD G12 (50%)	X					9000 / 5	
Motorex AG	Motorex Coolant G48 ready to use (50/50)	X	X				9000 / 5	
Navistar Inc.	Fleetrite 50/50 Prediluted Nitrite-Free Extended Life Coolant	X				X	9000 / 3	
Old World Industries Inc.	Blue Mountain Heavy Duty Extended Life Prediluted Coolant (50/50)	X				X	9000 / 3	
	Final Charge Global Extended Life Prediluted Coolant/ Antifreeze (50/50)	X				X	9000 / 3	
	Fleet Charge SCA Pre-charged 50/50 Prediluted Coolant		X	X			9000 / 3	
Penske Power Systems	Power Cool - HB500 Premix 50/50	X	X				9000 / 3	
Raloy Lubricantes	Antifreeze Long Life NF-300 Ready-to-Use (50:50)	X	X				9000 / 5	
Recochem	HD Expert™ Endurance 50-50 Prediluted	X				X	9000 / 3	
SMB - Sotragal / Mont Blanc	L.R.-30 Power Cooling (44%)	X	X				9000 / 5	
	L.R.-38 Power Cooling (52%)	X	X				9000 / 5	
Total Lubrifiants	Coolelf MDX -26 °C	X	X				9000 / 5	
	Coolelf MDX -37 °C	X	X				9000 / 5	
Tosol-Sintez	Glysantin Alu Protect G30 Ready Mix	X					9000 / 3	
	Glysantin Alu Protect G48 Ready Mix	X	X				9000 / 5	

TIM-ID: 0000034533 - 008

Manufacturer	Product/brand name	Organic Inhibitors					Operating time Hours / Years	Comments / Material number
		Silicon	Nitrite	Phosphatized	Molybdate			
Valentin Energie GmbH	Valentin Coolant Plus -25 °C Ready	X					9000 / 3	
Valvoline	Zerex G-05 50/50 Mix		X	X			9000 / 5	
	Zerex G-48 premix 50%	X	X				9000 / 5	
	OEM Advanced 48 premix 50%	X	X				9000 / 5	
Volvo Trucks	Road Choice 50/50 Predi- luted Nitrite-Free OAT Ex- tended Life Coolant	X				X	9000 / 3	
YPF S.A. Argentina	Kriox MTL 50	X				X	9000 / 3	

Table 94:

8.8 Coolant Additives for Two-Cycle Engines

8.8.1 Coolant without antifreeze – Concentrates for two-stroke cycle engines

For details and special features, see chapter on “Coolants” (→ Page 22)

Coolants without antifreeze – concentrates

Manufacturer	Product/brand name	Inhibitors					Operating time Hours / Years	Comments / Material number
		Organic	Silicon	Nitrite	Phosphatized	Molybdate		
Rolls-Royce Solutions GmbH	Coolant CS 100 Corrosion Inhibitor Concentrate	X					6000 / 2	X00057233 (20 l) X00057232 (210 l) Also available from Rolls-Royce Solutions Asia Pte. Ltd.
Rolls-Royce Solutions America Inc.	Power Cool®Plus 6000 Concentrate	X					6000 / 2	colored green 23533527 (1 gallon) 23533526 (5 gallons)
Arteco NV	Freeco NBI	X					6000 / 2	
BASF SE	Glyscorr G93 green	X					6000 / 2	X00058062 (canister) X00054105 (barrel)
CCI Corporation	A 216	X				X	6000 / 2	
CCI Manufacturing IL Corporation	A 216	X				X	6000 / 2	X00051509 (208 l)
Chevron Corp.	Texcool A – 200	X					6000 / 2	
Detroit Diesel Corp.	Power Cool Plus 6000	X				X	6000 / 2	colored red
	Power Cool 2000		X	X			6000 / 2	
	Power Cool 3000		X	X	X		4000 / 2	
Drew Marine	Drewgard XTA	X					6000 / 2	
ExxonMobil	Mobil Delvac Extended Life Corrosion Inhibitor	X				X	6000 / 2	
Old World Industries Inc.	Final Charge Extended Life Corrosion Inhibitor (A 216)	X				X	6000 / 2	
Penray	Pencool 2000		X	X			6000 / 2	
	Pencool 3000		X	X	X		4000 / 2	
Valvoline	ZEREX G-93		X				6000 / 2	
	OEM Advanced 93		X				6000 / 2	
YORK SAS	York 719		X				6000 / 2	

Table 95:

8.8.2 Coolant without antifreeze – Ready mixtures for two-stroke cycle engines

For details and special features, see chapter on “Coolants” (→ Page 22)

Coolant without antifreeze, ready mixtures

Manufacturer	Product name	Inhibitors					Operating time Hours / Years	Comments / Material number
		Organic	Silicone	Nitrite	Phosphatized	Molybdate		
Rolls-Royce Solutions GmbH	Coolant CS 10/90 Corrosion Inhibitor Premix		X				6000 / 2	X00069385 (20 l) X00069386 (210 l) (Sales region: Italy)

Table 96:

8.8.3 Antifreeze – Concentrates for two-stroke cycle engines

For details and special features, see chapter on “Coolants” (→ Page 22)

Antifreeze concentrates

Manufacturer	Product/brand name	Inhibitors					Operating time Hours / Years	Comments / Material number
		Organic	Silicon	Nitrite	Phosphatized	Molybdate		
Rolls-Royce Solutions GmbH	Coolant AH100 Antifreeze Concentrate	X	X				9000 / 5	X00057231 (20 l) X00057230 (210 l) Also available from Rolls-Royce Solutions Asia Pte. Ltd.
Rolls-Royce Solutions America Inc.	Power Cool®3149	X		X			9000 / 5	23528572 23528571
Alliance Automotive Service GmbH	NAPA Premium Kühlerschutz N48	X	X				9000 / 5	
Avia AG	Antifreeze APN	X	X				9000 / 5	
	Antifreeze APN - S	X					9000 / 3	
BASF SE	Glystantin G30 pink	X					9000 / 3	X00058072 (canister) X00058071 (barrel)
	Glystantin G48 blue green	X	X				9000 / 5	X00058054 (25 l) X00058053 (210 l)
BayWa AG	Tectrol Coolprotect	X	X				9000 / 5	
BP Lubricants	Aral Antifreeze Extra	X	X				9000 / 5	
Castrol	Castrol Radicool NF	X	X				9000 / 5	
CCI Corporation	L 415	X				X	9000 / 3	
Classic Schmierstoff GmbH + Co. KG	Classic Kolda UE G48	X	X				9000 / 5	
Comma Oil & Chemicals Ltd.	Comma Xstream® G30® Antifreeze Coolant Concentrate	X					9000 / 3	
	Comma Xstream® G48® Antifreeze Coolant Concentrate	X	X				9000 / 5	
COPARTS Autoteile GmbH	CAR1 Premium Longlife Kühlerschutz C48	X	X				9000 / 5	
Daimler Trucks North America	Alliance OAT Extended Life Coolant	X				X	9000 / 3	
Detroit Diesel Corp.	Power Cool Antifreeze		X	X			9000 / 3	
	Power Cool Plus Coolant	X				X	9000 / 3	
	Power Cool Diesel Engine Coolant		X	X			9000 / 3	
Drew Marine	Drewgard ZX	X					9000 / 3	

TIM-ID: 0000034540 - 008

Manufacturer	Product/brand name	Inhibitors					Operating time Hours / Years	Comments / Material number
		Organic	Silicon	Nitrite	Phosphatized	Molybdate		
ExxonMobil	Mobil Delvac Extended Life Coolant	X				X	9000 / 3	
	Mobil Antifreeze Advanced	X					9000 / 3	
	Mobil Antifreeze Extra	X	X				9000 / 5	
	Mobil Heavy Duty Coolant		X	X			9000 / 3	
	Mobil Mining Coolant		X	X			9000 / 3	
	Esso Antifreeze Advanced	X					9000 / 3	
	Esso Antifreeze Extra	X	X				9000 / 5	
Finke Mineralölwerk GmbH	AVIATICON Finkofreeze F30	X					9000 / 3	
	AVIATICON Finkofreeze F48	X	X				9000 / 5	
Fuchs Petrolub SE	Maintain Fricofin	X	X				9000 / 5	
	Maintain Fricofin G12 Plus	X					9000 / 3	X00058074 (canister) X00058073 (barrel)
INA Maziva Ltd.	INA Antifriz AI Super	X	X				9000 / 5	
Kuttenkeuler GmbH	Kuttenkeuler Antifreeze ANF KK 48	X	X				9000 / 5	
	Glycostar®ST 48	X	X				9000 / 5	
LLK-International (Lukoil Lubricants Co)	Lukoil Antifreeze HD G12 K	X					9000 / 3	
Lukoil Lubricants Europe GmbH	Lukoil Coolant Plus	X	X				9000 / 5	
	Lukoil Coolant SF	X					9000 / 3	
Mitan Mineralöl GmbH	Alpine C30	X					9000 / 3	
	Alpine C48	X	X				9000 / 5	
MJL Bangladesh	Omera Premium Coolant	X					9000 / 3	
MOFIN Deutschland GmbH & Co KG	MOFIN Kühlerschutz M48 Premium Protect	X	X				9000 / 5	
Motorex AG	Motorex Coolant G48	X	X				9000 / 5	
Nalco Water An Ecolab Company	Nalcool NF 48 C	X	X				9000 / 5	
Navistar Inc.	Fleetrice Nitrite-Free Extended Life Coolant	X				X	9000 / 3	
Old World Industries Inc.	Blue Mountain Heavy Duty Extended Life Coolant	X				X	9000 / 3	
	Fleet Charge SCA Pre-charged Coolant / Antifreeze		X	X			9000 / 3	
	Final Charge Global Extended Life Coolant/Antifreeze	X				X	9000 / 3	
	Peak Heavy Duty Coolant		X	X			9000 / 3	
Panolin AG	Panolin Anti-Frost MT-325	X	X				9000 / 5	

TIM-ID: 000.0034.540 - 008

Manufacturer	Product/brand name	Inhibitors					Operating time Hours / Years	Comments / Material number
		Organic	Silicon	Nitrite	Phosphatized	Molybdate		
Penske Power Systems	Power Cool - HB500	X	X				9000 / 3	
Raloy Lubricantes	Antifreeze Long Life NF-300 Concentrate	X	X				9000 / 5	
Recochem Inc.	HD Expert™ Endurance	X				X	9000 / 3	
	R 542	X	X				9000 / 3	
SMB - Sotragal / Mont Blanc	Antigel Power Cooling Concentrate	X	X				9000 / 5	
Total Lubrifiants	Glacelf MDX	X	X				9000 / 5	
Valvoline	Zerex G-30	X					9000 / 3	
	Zerex G-48	X	X				9000 / 5	
	OEM Advanced 30	X					9000 / 3	
	OEM Advanced 48	X	X				9000 / 5	
Volvo Trucks	Road Choice Nitrite-Free OAT Extended Life Coolant	X				X	9000 / 3	
YORK SAS	York 716	X	X				9000 / 5	

Table 97:

8.8.4 Antifreeze – Ready mixtures for two-stroke cycle engines

For details and special features, see chapter on “Coolants” (→ Page 22)

Antifreeze, ready mixtures

Manufacturer	Product/brand name	Inhibitors				Operating time Hours / Years	Comments / Material number
		Organic	Silicon	Nitrite	Phosphatized Molybdate		
Rolls-Royce Solutions GmbH	Coolant AH 35/65 Antifreeze Premix	X	X			9000 / 5	X00069382 (20 l) X00069383 (210 l) X00069384 (1000 l) (Sales region: Italy)
	Coolant AH40/60 Antifreeze Premix	X	X			9000 / 5	X00070533 (20 l) X00070532 (1000 l) (Sales region: England, Spain)
	Coolant AH 50/50 Antifreeze Premix	X	X			9000 / 5	X00070528 (20 l) X00070527 (1000 l) (Sales region: England)
Rolls-Royce Solutions America Inc.	Power Cool®Universal 35/65 mix	X	X			9000 / 5	800085 (5 gallons) 800086 (55 gallons)
	Power Cool®Universal 50/50 mix	X	X			9000 / 5	800071 (5 gallons) 800084 (55 gallons)
Bantleon	Avilub Antifreeze Mix (50 %)	X	X			9000 / 5	X00049213 (210 l)
BayWa AG	Tectrol Coolprotect Mix 3000	X				9000 / 3	Antifreeze protection down to -24 °C
Castrol	Castrol Radicool NF Premix (45%)	X	X			9000 / 5	
CCI Corporation	L 415 (50%)	X			X	9000 / 3	
Cepsa Comercial Petróleo S.A.U.	XTAR Super Coolant Hybrid NF 50%	X	X			9000 / 5	
Daimler Trucks North America	Alliance 50/50 Prediluted OAT Extended Life Coolant	X			X	9000 / 3	
Detroit Diesel Corp.	Power Cool Antifreeze premix 50/50		X	X		9000 / 3	
	Power Cool Plus Prediluted Coolant (50/50)	X			X	9000 / 3	
	Power Cool Prediluted 50/50 Diesel Engine Coolant		X	X		9000 / 3	

Manufacturer	Product/brand name	Inhibitors					Operating time Hours / Years	Comments / Material number
		Organic	Silicon	Nitrite	Phosphatized	Molybdate		
ExxonMobil	Mobil Delvac Extended Life Prediluted Coolant (50/50)	X				X	9000 / 3	
	Mobile Heavy Duty 50/50 Prediluted Coolant		X	X			9000 / 3	
	Mobile Mining 50/50 Prediluted Coolant		X	X			9000 / 3	
Finke Mineralölwerk GmbH	AVIATICON Finkofreeze F48 RM 50/50	X	X				9000 / 5	
	AVIATICON Finkofreeze F30 RM 40:60 +	X					9000 / 3	
LLK-International (Lukoil Lubricants Co)	Lukoil Antifreeze HD G12 (50%)	X					9000 / 3	
Motorex AG	Motorex Coolant G48 ready to use (50/50)	X	X				9000 / 5	
Navistar Inc.	Fleetrite 50/50 Prediluted Nitrite-Free Extended Life Coolant	X				X	9000 / 3	
Penske Power Systems	Power Cool - HB500 Pre-mix 50/50	X	X				9000 / 3	
Raloy Lubricantes	Antifreeze Long Life NF-300 Ready-to-Use (50:50)	X	X				9000 / 5	
Recochem	HD Expert™ Endurance 50-50 Prediluted	X				X	9000 / 3	
SMB - Sotragal / Mont Blanc	L.R.-30 Power Cooling (44%)	X	X				9000 / 5	
	L.R.-38 Power Cooling (52%)	X	X				9000 / 5	
Old World Industries Inc.	Blue Mountain Heavy Duty Extended Life Prediluted Coolant (50/50)	X				X	9000 / 3	
	Final Charge Global Extended Life Prediluted Coolant/Antifreeze (50/50)	X				X	9000 / 3	
	Fleet Charge SCA Pre-charged 50/50 Prediluted Coolant		X	X			9000 / 3	
Tosol-Sintez	Glysantin Alu Protect/G30 Ready Mix	X					9000 / 3	
	Glysantin Protect Plus/G48 Ready Mix	X	X				9000 / 5	

Manufacturer	Product/brand name	Inhibitors				Operating time Hours / Years	Comments / Material number
		Organic	Silicon	Nitrite	Phosphatized Molybdate		
Total Lubrificants	CoolElf MDX -26 °C	X	X			9000 / 5	
	CoolElf MDX -37 °C	X	X			9000 / 5	
Valentin Energie GmbH	Valentin Coolant Plus -25 °C Ready	X				9000 / 3	
Valvoline	Zerex G-48 premix 50%	X	X			9000 / 5	
	OEM Advanced 48 pre- mix 50%	X	X			9000 / 5	
Volvo Trucks	Road Choice 50/50 Pre- diluted Nitrite-Free OAT Extended Life Coolant	X			X	9000 / 3	
YPF S.A. Argentina	Kriox MTL 50	X			X	9000 / 3	

Table 98:

8.9 Coolant Additives with Limited Series Approval

8.9.1 Antifreeze – Concentrates and ready mixtures on ethylene-glycol basis for engines with and without light metal

Important
The antifreezes listed below can be used at an application concentration of 40 - 50% by volume. Exception: <ul style="list-style-type: none"> For model type 00 to 07 Series 2000 marine engines no more than 40% by volume is admissible.

Antifreeze concentrates

Manufacturer	Brand name	Inhibitors					Operating time Hours / Years	Comments / Material number
		Organic	Silicon	Nitrite	Phosphatized	Molybdate		
BASF SE	Glysantin®G40 pink (concentrate)	X	X				9000 / 3	X00066724 (20 l) X00066725 (210 l)
Finke Mineralölwerk GmbH	AVIATICON Finkofreeze F40	X	X				9000 / 3	
Lukoil Lubricants Europe GmbH	Lukoil Coolant SOT	X	X				9000 / 3	
MOFIN Deutschland GmbH & Co KG	MOFIN Kühlerschutz M40 Extra	X	X				9000 / 3	
Motorex AG	Motorex Coolant M4.0 Concentrate	X	X				9000 / 3	
Puma Energy International S.A.	Puma HD Hybrid Coolant	X	X				9000 / 3	
Valvoline	ZEREX G40 (concentrate)	X	X				9000 / 3	Material number (USA): 800180 (Drum)
	OEM Advanced 40	X	X				9000 / 3	

Table 99:

Antifreeze, ready mixtures

Manufacturer	Brand name	Inhibitors					Operating time Hours / Years	Comments / Material number
		Organic	Silicon	Nitrite	Phosphatized	Molybdate		
Motorex AG	Motorex Coolant M4.0 Ready to use	X	X				9000 / 3	Antifreeze protection up to -38 °C (50% by volume)
Puma Energy International S.A.	Puma HD Hybrid Coolant 5050	X	X				9000 / 3	(50% by volume)

Table 100:

8.9.2 Antifreeze – Ready mixtures based on propylene glycol for engine series free of light metal

Antifreeze, ready mixture

Important

Propylene glycol based coolants (→ Page 191) are approved for Series 4000 model types 01 to 05 used in genset applications.
 Restrictions apply to the use of propylene glycol based coolants for various model types in all other Series 4000 applications. See (→ Page 147)
 For Series 4000C01 to C03 and 4000R01 to R03 only an application concentration of 40% is admissible. A 50/50 mixture must not be used!

Manufacturer	Brand name	Inhibitors					Operating time Hours / Years	Comments / Material number
		Organic	Silicon	Nitrite	Phosphatized	Molybdate		
Fleetguard	PG XL (40%) ready mixture		X	X	X	X	9000 / 3	
	ES Compleat PG Premix 50/50		X	X	X	X	9000 / 3	

Table 101:

9 Flushing and Cleaning Specifications for Engine Coolant Circuits

9.1 General information

These cleaning instructions apply to mtu diesel and gas engines.

Assemblies installed in the engine cooling circuits are e.g. expansion tank, preheater, heat exchanger, coolant cooler, oil heat exchanger, intercooler, charge-air preheater, fuel preheater etc.

In the course of time, sludge deposits from aging coolant additives can accumulate in the coolant circuits. Reduced cooling capacity, clogged vent lines and drain points and dirty coolant level sight glasses can result.

Inadequate water quality or incorrect coolant preparation can also heavily contaminate the system.

If such conditions occur, the coolant circuit must be flushed out with fresh water, repeatedly if necessary.

If these flushing sequences are insufficient or if the system is too heavily contaminated, the coolant circuit and all affected assemblies must be cleaned.

Only clean, fresh water (no river or seawater) must be used for flushing.

Only products approved by Rolls-Royce Solutions GmbH or corresponding products at the specified concentrations may be used for cleaning. The specified cleaning procedure must be complied with.

Immediately after flushing or cleaning, fill the coolant circuits with treated engine coolant as stipulated in the current Fluids and Lubricants Specifications A001061/.. (→ Page 147). Otherwise there is a danger of corrosion!

Important

Fluids and lubricants (e.g. treated engine coolant), used flushing water, cleaning agents and cleaning solutions can be hazardous materials. Certain regulations must be observed when handling, storing and disposing of these substances.

These regulations are contained in the manufacturer's instructions, statutory requirements and technical guidelines valid in the individual countries. Considerable differences can apply from country to country so that no generally valid statement on the applicable regulations for fluids and lubricants etc. can be made in this publication.

Users of the products named in these specifications are therefore obliged to inform themselves of the locally valid regulations and to follow them strictly. Rolls-Royce Solutions GmbH accepts no responsibility whatsoever for improper or illegal use of the fluids and lubricants / cleaning agents which it has approved.

Important

Scrap oil heat exchangers from engines with bearing or piston seizures or friction damage!

Test equipment, auxiliary materials and fluids and lubricants

mtu test kit or electrical pH-value measuring instrument

- Freshwater
- Prepared engine coolant
- Superheated steam
- Compressed air

9.2 Fresh water requirements for cleaning solutions and flushing water

Important

Only clean, clear water with values in accordance with those in the following table must be used for preparing cleaning solutions. If the limit values for the water are exceeded, hardness or mineral content can be decreased by adding demineralized water.

Item	Minimum	Maximum
Total earth alkalines ¹⁾ (water hardness)	0 mmol/l 0°d	2.7 mmol/l 15°d
pH-value at 20 °C	5.5	8.0
Chloride ions		100 mg/l
Sulfate ions		100 mg/l
Total chloride + sulfate ions		200 mg/l
Bacteria		10 ³ CFU (colony forming unit)/ml
Fungi, yeasts	are not permitted!	

Table 102:

¹⁾ = Common designations for water hardness in various countries: 1 mmol/l = 5.6°d = 100 mg/kg CaCO₃

- 1°d = 17.9 mg/kg CaCO₃, USA hardness
- 1°d = 1.79° French hardness
- 1°d = 1.25° English hardness

Important

The cleaning agent concentrates used for the preparation of the cleaning solution, may not contain more than 100 mg/l chloride and/or 100 mg/l sulfate.

9.3 Approved cleaning agents

Manufacturer	Product name	Working concentration		Order no.
For coolant systems:				
Klute	Hakutex 111 ^{1, 5)}	2% by volume	Liquid	X00065751
	Decorrdal 20-1 ⁸⁾	10% by volume	Liquid	⁷⁾
	Hakupur 50-706-3 ⁴⁾	2% by volume	Liquid	X00055629
For cooling circuit assemblies:				
Henkel	Bonderite C-AK FD ²⁾	1 to 10% by weight	Powder	⁷⁾
	Bonderite C-MC 11120 ³⁾	2 to 10% by weight	Powder	⁷⁾
Klute	Hakutex 60 mtu ⁹⁾	100% by volume	Liquid	X00070585 (25 kg)
For coolant systems contaminated with bacteria, fungi or yeast (so-called system cleaners):				
Vink Chemicals	Grotan WS Plus ⁵⁾	0.15% by volume	Liquid	X00065326 (10 kg)
	Grotanol SR2 ⁶⁾	0.5% by volume	Liquid	X00069827 (10 kg)

Table 103:

¹⁾ For light lime deposits, light corrosion

²⁾ For lime deposits containing oil and grease

³⁾ Preferred for heavy lime deposits

⁴⁾ For oily and greasy residues. Not suitable for galvanized surfaces

⁵⁾ Bacteria contamination up to 10^4

⁶⁾ Bacteria contamination up to $> 10^4$, contamination with fungi and yeast

⁷⁾ Not stocked by Rolls-Royce Solutions

⁸⁾ With serious corrosion; not permitted for aluminum materials

⁹⁾ Solvent cold cleaner for oily and greasy residues

Important

The technical data sheets and safety data sheets of the product must be observed!

The cleaning agents are available world-wide through the branches of the manufacturers or their trading partners.

9.4 Engine coolant circuits - Flushing

1. Drain engine coolant.
2. Measure the pH value of the freshwater using the mtu test kit or an electrical pH value measuring device.
3. Fill freshwater into the coolant circuit.

Important

Never pour cold water into a hot engine!

4. Preheat the engine, start it up and run until warm.
5. Run engine at increased speed for approx. 30 minutes.
6. Take flushing liquid sample at engine-coolant-sample extraction cock.
7. Shut down engine.
8. Drain flushing liquid.
9. Measure pH value of flushing liquid sample using the mtu test kit or electrical pH value measuring device and compare with the pH value of the freshwater.
 - a) pH value difference < 1: Fill system with treated coolant and start engine.
 - b) pH value difference > 1: Fill with fresh flushing liquid and repeat flushing cycle.
 - c) If the pH value difference is still > 1 even after flushing 4 to 5 times the coolant circuit must be cleaned, see (→ Page 196). The assemblies may also need cleaning, see (→ Page 198).

Important

Refer to the engine operating instructions for additional information.

9.5 Engine coolant circuits – Cleaning

1. Mix cleaner to the specified concentration with freshwater. Use warm freshwater (45 °C) if the engine is warm.
2. Cleaning agents for coolant circuits are prepared in warm freshwater as a concentrated solution, see (→ Page 194).
3. In the case of powdered products, stir until the cleaning agent is completely dissolved and without sediment.
4. Pour solution together with freshwater into coolant circuit.
5. Start engine and run until warm.
6. Select temperature and duration of residence time according to the specifications of the technical data sheets of the manufacturer.
7. Shut down engine.
8. Drain off cleaning agents and flush the engine coolant circuit with fresh water.
9. Take flushing liquid sample at engine-coolant-sample extraction cock.
10. Measure pH value of flushing liquid sample using the mtu test kit or electrical pH value measuring device and compare with the pH value of the freshwater.
 - a) pH value difference < 1: Fill system with treated coolant and start engine.
 - b) pH value difference > 1: Clean assemblies, see (→ Page 198).

Important

Refer to the engine operating instructions for additional information.

9.6 Removal of heavy corrosion in coolant circuits using Decorrda 20-1

1. Drain all coolant from engine coolant circuit.
2. Fill engine coolant circuit with fresh water and flush the cooling system.
3. Drain flush water completely.
4. Fill coolant circuit completely with a water solution containing 10% Decorrda 20-1.
5. Start engine and run to operating temperature, 20 minutes.
6. Perform cleaning cycle with the engine running, with circulating Decorrda 20-1, duration: 4 hours.
7. Vent the coolant circuit several times while running the cleaning cycle to ensure complete filling.
8. Allow the engine to cool down to approx. 45 °C.
9. When the temperature reaches 45 °C, drain Decorrda 20-1.
10. First flushing cycle: Fill the coolant circuit with 10% Glysacorr P113 solution in water immediately after draining the cleaning solution.
11. Operate the engine for 30 minutes, vent the coolant circuit several times.
12. Allow the engine to cool down to 45 °C.
13. Drain the Glysacorr P113 flushing solution completely.
14. Second flushing cycle: Fill coolant circuit again with a fresh water solution containing 10% Glysacorr P113.
15. Operate the engine for 30 minutes, vent the coolant circuit several times.
16. Allow the engine to cool down to 35 °C.
17. Drain the Glysacorr P113 flushing solution completely.
18. Fill engine with coolant.
19. Rust removal is complete.
20. Put engine into operation.

Important

The engine coolant circuit must always be vented properly to ensure complete filling. This applies when filling the engine with water, cleaning agent, corrosion inhibitor and coolant as well as in engine operation with one of the mentioned media.

In zones where air is present, neither rust removal nor preservation take place, and corrosion occurs again. All crankcase openings, hose connection openings, etc. must be closed immediately if no longer required. There is a risk of corrosion in the area of the openings.

9.7 Cleaning engine coolant circuit assemblies

1. Remove, disassemble and clean assemblies in the engine coolant circuit that are exposed to heavy sludge deposits e.g. expansion tanks, preheating units, heat exchangers (coolant cooler, oil heat-exchanger, charge-air cooler, charge-air preheater, fuel preheater etc.) and lower sections of pipework.
2. Before cleaning, examine degree of contamination on water sides.
3. In case of lime deposits that contain oil and grease, degrease the water side first.
4. Deposits in charge-air coolers caused by oil mist can be removed using Kluthe Hakutex 60.
5. Remove hard lime deposits with a decalcifying product. In the event of stubborn lime deposits, if necessary a 10% inhibited hydrochloric acid solution may have to be used.
6. Dissolve deposits on and in heat-exchanger elements in a heated cleaning bath. Observe the manufacturer's specifications and use only approved detergents in the permissible concentration, see (→ Page 194)

Important

Deposits on the oil side can also be dissolved in a kerosene bath.
The dwell time in the cleaning bath depends on the type and degree of contamination, as well as the temperature and activity of the bath.

7. Clean individual components such as housings, covers, pipes, sight glasses, heat-exchanger elements with superheated steam, a nylon brush (soft) and a powerful water jet.

Important

In order to avoid damage:
Do not use hard or sharp-edged tools (steel brushes, scrapers, etc.) (oxide protective layer).
The pressure of the water jet must not be ≤ 60 bar (to avoid damage, e.g. of the cooler fins).

8. After cleaning, blow through the heat exchanger elements with low-pressure steam in the direction opposite to operational flow, rinse with clear water (until pH-value difference is < 1) and blow dry with compressed or hot air.
9. Check that all components are in perfect condition, repair or replace as necessary.
10. Flush oil and engine coolant sides of heat-exchanger elements with corrosion-inhibiting oil. This step may be omitted if the heat exchanger is installed and taken into service immediately after cleaning.
11. After installing all assemblies, flush engine coolant circuit once, see (→ Page 195).
12. Check coolant system for leaks during initial operation of engine.

Important

For further information, see the Maintenance Manual for the engine in question.

9.8 Coolant circuits contaminated with bacteria, fungi or yeast

System cleaning

The system cleaner must flow a sufficiently long time through the complete cooling system to ensure effective cleaning and disinfection.

Therefore, the predefined amount of the approved system cleaner must be added to the contaminated coolant in the system, see (→ Page 194). Use a circulating pump to provide continuous mixture flow through the coolant system for at least 24 hours or max. 48 hours.

Flushing

When the coolant and system cleaner have been drained, the cooling circuit must be flushed with fresh water. Flushing must be carried out until no more contaminants are visible and the flushing liquid has the same pH-value as the fresh water used (max. pH-value difference < 1).

Refill

Before refilling the circuit, make sure the system is free of contaminants.

Refill must be performed directly after flushing to avoid the risk of corrosion!

10 Cleaning the Product Externally

10.1 General information

If, in the course of time, contaminants such as oil deposits and leaves have accumulated on the engine, it might be necessary to clean it. This should be done with due care and only on the surface.

Wash-cleaning the engine can - at the worst - have the opposite effect if it is carried out incorrectly.

Before getting started and using cleaning agents, electrical components (battery-charging generator, plug connections, ignition cables etc.) and the air intake should be protected with covers to avoid water ingress into the plug connections or combustion chambers, which could cause damage.

Only clean freshwater (no river or sea water) must be used for spray-washing.

All plug connections should be checked and, if necessary, blown out with compressed air after cleaning to avoid misfiring and other electrical problems.

Only products approved by Rolls-Royce Solutions GmbH at the specified concentrations may be used for cleaning. The specified cleaning procedure is to be complied with.

Important

Cleaning must be carried out with pressure washers at an operating pressure of ≤ 60 bar to avoid damage to the cooler and the engine. High-pressure cleaners with an operating pressure > 60 bar are not permitted.

After the clean-washing procedure, the equipment must be thoroughly rinsed with freshwater. The specifications in the chapter "Fresh water requirements for cleaning solutions and flushing water" are applicable. The technical data sheets and safety data sheets of the product must be observed!

Important

Fluids and lubricants (e.g. treated engine coolant), used flushing water, cleaning agents and cleaning solutions can be hazardous materials. Certain regulations must be obeyed when handling, storing and disposing of these substances.

These regulations are contained in the manufacturer's instructions, statutory requirements and technical guidelines valid in the individual countries. Considerable differences can apply from country to country so that no generally valid statement on the applicable regulations for fluids and lubricants etc. can be made in this publication.

Users of the products named in these specifications are therefore obliged to inform themselves of the locally valid regulations. Rolls-Royce Solutions GmbH accepts no responsibility whatsoever for improper or illegal use of the fluids and lubricants / cleaning agents which it has approved.

Test equipment, auxiliary materials and fluids and lubricants

mtu test kit or electrical pH-value measuring instrument

- Freshwater
- Superheated steam
- Compressed air

10.2 Approved cleaning agents

Manufacturer	Product name	Working concentration		Order no.
For remote cooler on air side:				
Kluthe GmbH	Hakupur 50 K ¹⁾	0.5% by volume - 5% by volume	Liquid	X00070940 ²⁾
For cleaning painted, contaminated surfaces externally:				
Kluthe GmbH	Hakupur 449 ¹⁾	1% by volume	Liquid	X00071179 ²⁾

Table 104:

¹⁾ Cleaning agent for cleaning with high-pressure cleaning device (parameter: Pressure: ≤ 60 bar, gentle spray jet, distance from nozzle to object at least 25 cm, cleaning agent temperature: 80 °C)

²⁾ Not stocked by Rolls-Royce Solutions

Important

The technical data sheets and safety data sheets of the product must be observed!

The cleaning agents are available world-wide through the branches of the manufacturers or their trading partners.

11 Revision Overview

11.1 Revision overview from version A001061/40 to A001061/41

Seq. No.	Page	Chapter	Subsection	Action	Supplement/ comments
1		Title sheet	Cover page	Revised	
2	(→ Page 0)	Copyright		Revised	New version
3	(→ Page 5)	Preface	General information	Revised	Complete subsection
4	(→ Page 7)	Lubricants for four-stroke cycle engines	Engine oils	Revised	Complete subsection
5	(→ Page 17)	Lubricants for four-stroke cycle engines	Lubricating greases	Revised	Complete subsection
6	(→ Page 19)	Lubricants for two-stroke cycle engines	Engine oils	Revised	Complete subsection
7	(→ Page 22)	Coolant	General information	Revised	Complete subsection
8	(→ Page 24)	Coolant	Unsuitable materials in the coolant circuit	Revised	Complete subsection
9	(→ Page 25)	Coolant	Requirements imposed on freshwater	Revised	Complete subsection
10	(→ Page 26)	Coolant	Emulsifiable corrosion inhibitor oils	Revised	Complete subsection
11	(→ Page 28)	Coolant	Antifreeze	Revised	Complete subsection
12	(→ Page 30)	Coolant	Coolant without antifreeze	Revised	Complete subsection
13	(→ Page 31)	Coolant	Operational monitoring	Revised	Complete subsection
14	(→ Page 36)	Coolant	Storage capability of coolant concentrates	Revised	Table
15	(→ Page 38)	Fuels	Diesel fuels – General information	Revised	Complete subsection
16	(→ Page 45)	Series-dependent approval of fuel grades for mtu engines	Distillate fuels as per DIN EN590 and ASTM D975	Revised	Table

TIM-ID: 0000009956 - 008

Seq. No.	Page	Chapter	Subsection	Action	Supplement/ comments
17	(→ Page 51)	Series-depend-ent approval of fuel grades for mtu engines	British Standard	Revised	Table
18	(→ Page 54)	Series-depend-ent approval of fuel grades for mtu engines	Chinese distil-late fuels ac-cording to GB 19 147-2016, GB 252-2015 and GB 174 11-2016	Revised	Table
19	(→ Page 60)	Series-depend-ent approval of fuel grades for mtu engines	Heating oil	Revised	Table
20	(→ Page 65)	Series-depend-ent approval of fuel grades for mtu engines	Marine distillate fuels in accord-ance with ISO 8217:2017	Revised	Table
21	(→ Page 73)	Series-depend-ent approval of fuel grades for mtu engines	Aviation turbine fuel	Revised	Table
22	(→ Page 76)	Series-depend-ent approval of fuel grades for mtu engines	NATO diesel fuels	Revised	Table
23	(→ Page 89)	Series-depend-ent approval of fuel grades for mtu engines	Paraffinic diesel fuel according to DIN EN 15940	Revised	Complete sub-section
24	(→ Page 90)	Series-depend-ent approval of fuel grades for mtu engines	Engine opera-tion on diesel fuel with a bio-diesel content of up to 30%	Revised	Complete sub-section
25	(→ Page 95)	Fuels	Engine opera-tion on pure bio-diesel (B100) and vegetable oil	Revised	Complete sub-section
26	(→ Page 98)	Fuels	Diesel fuels for engines with ex-haust gas after-treatment (EGAT)	Revised	Complete sub-section
27	(→ Page 100)	Fuels	Heating oil EL	Revised	Complete sub-section
28	(→ Page 101)	Fuels	Supplementary fuel additives	Revised	Complete sub-section

Seq. No.	Page	Chapter	Subsection	Action	Supplement/ comments
29	(→ Page 105)	NOx reducing agent AUS 32 / AUS 40 for SCR exhaust gas aftertreatment systems	General information	Revised	Complete subsection
30	(→ Page 107)	Approved engine oils and lubricating greases	Series-based usability of engine oils of oil category 1	Revised	Complete subsection (7.1.1)
31	(→ Page 111)	Approved engine oils and lubricating greases	Series-based usability of engine oils of oil categories 2 and 2.1 (low SAPS oils)	Revised	Complete subsection (7.1.4)
32	(→ Page 114)	Approved engine oils and lubricating greases	Single-grade oils – Category 2, SAE grades 30 and 40 for diesel engines	Revised	Complete subsection (7.1.5)
33	(→ Page 117)	Approved engine oils and lubricating greases	Multi-grade oils – Category 2, SAE grades 10W-30, 10W-40, 15W-40 and 20W-40 for diesel engines	Revised	Complete subsection (7.1.6)
34	(→ Page 127)	Approved engine oils and lubricating greases	Multi-grade oils – Category 2.1 (Low SAPS oils), SAE grades 0W-30, 10W-30, 5W-40, 10W-40 and 15W-40 for diesel engines	Revised	Complete subsection (7.1.7)
35	(→ Page 131)	Approved engine oils and lubricating greases	Series-based usability of engine oils of oil categories 3 and 3.1 (low SAPS oils)	Revised	Complete subsection (7.1.8)
36	(→ Page 133)	Approved engine oils and lubricating greases	Multi-grade oils – Category 3, SAE grades 5W-30, 5W-40, 10W-40 and 15W-40 for diesel engines	Revised	Complete subsection (7.1.9)

Seq. No.	Page	Chapter	Subsection	Action	Supplement/ comments
37	(→ Page 138)	Approved engine oils and lubricating greases	Multi-grade oils – Category 3.1 (Low SAPS oils), SAE grades 5W-30, 10, 10W-30 and W-40 for diesel engines	Revised	Complete subsection (7.1.10)
38	(→ Page 145)	Approved engine oils and lubricating greases	Engine oils for two-stroke cycle engines	Revised	Table (7.2.2)
39	(→ Page 147)	Approved coolants	Series- and application-based usability of coolant additives	Revised	Complete subsection (8.1)
40	(→ Page 156)	Approved coolants	Coolant without antifreeze – Concentrates for cooling systems containing light metal	Revised	Complete subsection (8.3.1)
41	(→ Page 157)	Approved coolants	Coolant without antifreeze – Ready mixtures for cooling systems containing light metal	Revised	Entire subsection (8.3.2)
42	(→ Page 158)	Approved coolants	Coolants without antifreeze – Concentrates for cooling systems free of light metal	Revised	Complete subsection (8.4.1)
43	(→ Page 160)	Approved coolants	Coolant without antifreeze – Ready mixtures for cooling systems free of light metal	Revised	Complete subsection (8.4.2)
44	(→ Page 161)	Approved coolants	Antifreeze – Concentrates for cooling systems containing light metal	Revised	Complete subsection (8.5.1)
45	(→ Page 164)	Approved coolants	Antifreeze – Ready mixtures for cooling systems containing light metals	Revised	Complete subsection (8.5.2)

Seq. No.	Page	Chapter	Subsection	Action	Supplement/ comments
46	(→ Page 167)	Approved coolants	Antifreeze concentrates for cooling systems free of light metal	Revised	Complete subsection (8.6.1)
47	(→ Page 171)	Approved coolants	Antifreeze – Ready mixtures for cooling systems free of light metals	Revised	Complete subsection (8.6.2)
48	(→ Page 174)	Approved coolants	Coolant without antifreeze – Concentrates for Series 60 engines	Revised	Complete subsection (8.7.1)
49	(→ Page 175)	Approved coolants	Coolant without antifreeze – Ready mixtures for Series 60 engines	Revised	Complete subsection (8.7.2)
50	(→ Page 176)	Approved coolants	Antifreeze – Concentrates for Series 60 engines	Revised	Complete subsection (8.7.3)
51	(→ Page 179)	Approved coolants	Antifreeze – Ready mixtures for Series 60 engines	Revised	Complete subsection (8.7.4)
52	(→ Page 182)	Approved coolants	Coolant without antifreeze – Concentrates for two-stroke cycle engines	Revised	Complete subsection (8.8.1)
53	(→ Page 183)	Approved coolants	Coolant without antifreeze – Ready mixtures for two-stroke cycle engines	Revised	Complete subsection (8.8.2)
54	(→ Page 184)	Approved coolants	Antifreeze – Concentrates for two-stroke cycle engines	Revised	Complete subsection (8.8.3)
55	(→ Page 187)	Approved coolants	Antifreeze – Ready mixtures for two-stroke cycle engines	Revised	Complete subsection (8.8.4)

TIM-ID: 000000956 - 008

Seq. No.	Page	Chapter	Subsection	Action	Supplement/ comments
56	(→ Page 190)	Approved coolants	Antifreeze concentrates and ready mixtures on ethylene-glycol basis for series with and without light metal	Revised	Complete subsection (8.9.1)
57	(→ Page 191)	Approved coolants	Antifreeze ready mixtures based on propylene glycol for series free of light metal	Revised	Complete subsection (8.9.2)
58	(→ Page 192)	Flushing and Cleaning Specifications for Engine Coolant Systems	General information	Revised	Complete chapter
59	(→ Page 194)	Flushing and Cleaning Specifications for Engine Coolant Systems	Approved cleaning agents	Revised	Complete chapter

Table 105:

12 Appendix A

12.1 Index

A

Additives

- Biocide 101
- Supplementary fuel additives 101
- Wear protection 101

Applicability of the publication 5

Approved fluids and lubricants

- Coolant
 - Antifreeze - Concentrates for Series 60 engines 176
 - Antifreeze - Concentrates for two-stroke cycle engines 184
 - Antifreeze - Ready mixtures for Series 60 engines 179
 - Antifreeze - Ready mixtures for two-stroke cycle engines 187
 - Coolant without antifreeze - Concentrates for Series 60 engines 174
 - Coolant without antifreeze - Concentrates for two-stroke cycle engines 182
- Coolant without antifreeze - Ready mixtures for Series 60 engines
 - Ready mixtures 175
- Coolants
 - Ready mixtures 183
- Engine oils for four-stroke cycle engines
 - Series-based restrictions for engine oils of oil category 1 107
 - Series-based usability of engine oils of oil categories 2 and 2.1 (low SAPS oils) 111
 - Series-based usability of engine oils of oil categories 3 and 3.1 (low SAPS oils) 131
- Engine oils for two-stroke cycle engines 145

Approved fluids and lubricants

- Engine oils for two-cycle engines
 - Series-based usability for two-cycle engine oils 144

B

Biodiesel 95

C

Cleaning

- General information 200

Cleaning agent

- System cleaner 199

Cleaning agents 194, 201

Cleaning specifications

- Assemblies 198
- Engine coolant circuit 196, 197
- System cleaner 199

Color additive

- Coolant circuit 37

Coolant

- Antifreeze 28
 - Concentrates for cooling systems containing light metal 161
 - Concentrates for cooling systems free of light metal 167
 - Ready mixtures for cooling systems containing light metals 164
 - Ready mixtures for cooling systems free of light metal 171
- Antifreeze, limited approval for engine series
 - Concentrates and ready mixtures on ethylene-glycol basis 190
- Antifreeze, limited series approval
 - Ready mixtures based on propylene glycol 191
- Coolant without antifreeze
 - Concentrates for cooling systems containing light metal 156, 158
 - Ready mixtures for cooling systems containing light metal 157
 - Ready mixtures for cooling systems free of light metal 160
- Emulsifiable corrosion inhibitor oils 26
- Freshwater requirements 25
- General information 22
- Limit values 35
- mtu test kit 31
- Operational monitoring 31
- pH value 35
- Storage capability 36
- Treatment 25

Coolant circuit

- Assembly cleaning 198
- Cleaning 196, 197
- Cleaning agents 194, 201
- Flushing 195
- Leakage 37
- Materials 24

Coolant without antifreeze

- Antifreeze 30

D

Diesel fuel 101

- B20 90
- Biodiesel 95
- Heating oil EL 100
- Supplementary fuel additives 101

- Diesel fuel approvals
 - British Standard 51
 - Chinese distillate fuels 54
- DIN EN 15940
 - Paraffinic diesel fuel 89
- DIN EN590, ASTM D975
 - Distillate fuels 45
- Dye additives
 - Lube oil circuit 17

E

- Emulsifiable corrosion-inhibiting oils 155
- Engine coolant circuit
 - Assembly cleaning 198
 - Cleaning 196, 197
 - Cleaning agents 194
 - Flushing 195
- Engine oil
 - Low SAPS
 - Category 3.1 138
 - Low SAPS oils
 - Caterogry 2.1 127
 - Multigrade oil
 - Category 1 110
 - Multi-grade oil
 - Category 2 117
 - Category 2.1 (Low SAPS oils) 127
 - Category 3 133
 - Category 3.1 (Low SAPS oil) 138
 - Single-grade oil
 - Category 1 109
 - Category 2 114
- Engine preservation 5
- Engine wash-cleaning procedure
 - Cleaning agents 201

F

- FAME 95
- Flushing and cleaning specifications for engine coolant circuits
 - General information 192
- Flushing specifications
 - Assemblies 198
 - Coolant circuits contaminated with bacteria, fungi or yeast 199
 - Engine coolant circuits 195
- Fuel system
 - Materials 104
- Fuels
 - Aviation turbine fuel 73
 - Diesel fuels 38, 98
 - Heating oil 60
 - Marine distillate fuels 65
 - NATO diesel fuels 76

H

- Heating oil EL 100

I

- Information on use 5

L

- Leakage
 - Coolant circuit 37
- Leaks
 - Lube oil circuit 17
- Lube oil circuit
 - Leaks 17
- Lubricants for four-stroke cycle engines
 - Engine oils 7
- Lubricants for two-stroke cycle engines
 - Engine oils 19
- Lubricating grease
 - General application 18, 146
 - Requirements 18
 - Special application 18

M

- Materials
 - Coolant circuit 24
 - Fuel system 104

N

- NOx reducing agent AUS 32/AUS 40 for SCR systems
 - General information 105

O

- Oil change interval
 - Biodiesel operation 95
- Operational monitoring
 - Coolant 31

R

- Requirements
 - Coolant circuit 24
 - Fuel system 104
- Revision overview from version A001061/40 to A001061/41 202

S

- Series- and application-based usability of coolant additives 147
- Storage
 - Coolant 36