



Fluids and Lubricants Specifications

Diesel engine-generator sets
with mtu Series 2000 and 4000 engines

A001064/14E



Rolls-Royce Solutions refers to Rolls-Royce Solutions GmbH or an affiliated company pursuant to §15 AktG (German Stock Corporation Act) or a controlled company (joint venture), and Rolls-Royce Solutions Ruhstorf GmbH.

© Copyright Rolls-Royce Solutions

This publication is protected by copyright and may not be used in any way, whether in whole or in part, without the prior written consent of Rolls-Royce Solutions. This particularly applies to its reproduction, distribution, editing, translation, microfilming and storage and/or processing in electronic systems including databases and online services.

All information in this publication was the latest information available at the time of going to print. Rolls-Royce Solutions reserves the right to change, delete or supplement the information provided as and when required.

Table of Contents

1 Preface			
1.1 General information	5	4.2.9 Engine operation on diesel fuel with a biodiesel content of up to 30%	63
2 Lubricants		4.3 Engine operation on pure biodiesel (B100) and vegetable oil	68
2.1 Engine oils – General information	8	4.4 Diesel fuels for engines with exhaust gas aftertreatment (EGAT)	71
2.2 Series-based usability for engine oils	15	4.5 Heating oil EL	73
2.3 Fluorescent dyestuffs for detecting leakage in the lube oil circuit	16	4.6 Supplementary fuel additives	74
2.4 Lubricating greases	17	4.7 Unsuitable materials in the diesel fuel circuit	78
2.5 mtu Advanced Fluid Management System for engine oils – Test package for North America	18	4.8 mtu Advanced Fluid Management System for fuels – Test package for North America	79
3 Coolants		5 NOx Reducing Agent AUS 32 / AUS 40 for SCR Exhaust Gas Aftertreatment Systems	
3.1 Coolants – General information	19	5.1 General information	81
3.2 Unsuitable materials in the coolant circuit	25	6 Approved Engine Oils and Lubricating Greases	
3.3 Requirements imposed on freshwater	26	6.1 Single-grade oils – Category 1, SAE grades 30 and 40 for diesel engines	83
3.4 Emulsifiable corrosion-inhibiting oils	27	6.2 Multi-grade oils – Category 1, SAE grade 15W-40 for diesel engines	85
3.5 Antifreeze	28	6.3 Single-grade oils – Category 2, SAE grades 30 and 40 for diesel engines	86
3.6 Coolant without antifreeze	30	6.4 Multi-grade oils – Category 2, SAE grades 10W-30, 10W-40, 15W-40 and 20W-40 for diesel engines	90
3.7 Operational monitoring	31	6.5 Multi-grade oils – Category 2.1 (Low SAPS oils), SAE grades 0W-30, 10W-30, 5W-40, 10W-40 and 15W-40 for diesel engines	103
3.8 Limit values for coolants	35	6.6 Multi-grade oils – Category 3, SAE grades 5W-30, 5W-40, 10W-40 and 15W-40 for diesel engines	110
3.9 Coolant concentrates – Storage capability	36	6.7 Multi-grade oils – Category 3.1 (Low SAPS oils), SAE grades 5W-30, 10W-30 and 10W-40 for diesel engines	115
3.10 Color additives to detect leakage in the coolant circuit	37	6.8 Lubricating Greases	122
3.11 mtu Advanced Fluid Management System for coolant – Test package for North America	38	6.8.1 Lubricating greases for general applications	122
4 Liquid Fuels		6.8.2 Lubricating greases for diesel engine-generator set components	123
4.1 Diesel fuels – General information	40	7 Approved Coolants	
4.2 Series-dependent approval of fuel grades for mtu engines	46	7.1 Series-based usability of coolant additives	124
4.2.1 Distillate fuels according to EN 590 and ASTM D975	46	7.2 Coolants without antifreeze for cooling systems containing light metal	125
4.2.2 British Standard 2869	49		
4.2.3 Chinese distillate fuels according to GB 19147-2016, GB 252-2015 and GB 17411-2016	50		
4.2.4 Heating oil	52		
4.2.5 Marine distillate fuels according to ISO 8217:2018-10	53		
4.2.6 Aviation turbine fuels	55		
4.2.7 NATO diesel fuels	56		
4.2.8 Paraffinic diesel fuel in accordance with EN 15940	60		

7.2.1	Coolant without antifreeze – Concentrates for cooling systems containing light metal	125	7.6.2	Antifreeze – Ready mixtures based on propylene glycol for engine series not containing light metal	147
7.2.2	Coolant without antifreeze – Ready mixtures for cooling systems containing light metal	126			
7.3	Coolants without antifreeze for cooling systems free of light metal	127	8	Flushing and Cleaning Specifications for Engine Coolant Circuits	
7.3.1	Coolants without antifreeze – Concentrates for cooling systems not containing light metal	127	8.1	General information	148
7.3.2	Coolant without antifreeze – Ready mixtures for cooling systems not containing light metal	129	8.2	Freshwater requirements for cleaning solutions and flushing water	149
7.4	Antifreezes for cooling systems containing light metal	130	8.3	Approved cleaning agents	150
7.4.1	Antifreeze – Concentrates for cooling systems containing light metal	130	8.4	Engine coolant circuits – Flushing	151
7.4.2	Antifreeze – Ready mixtures for cooling systems containing light metals	133	8.5	Engine coolant circuits – Cleaning	152
7.4.3	Antifreeze – Approved coolants for Series 2000Gx6 with intercooler option (TB)	136	8.6	Removal of heavy corrosion in coolant circuits using Decorrdal 20-1	153
7.5	Antifreezes for cooling systems free of light metal	138	8.7	Cleaning engine coolant circuit assemblies	154
7.5.1	Antifreeze – Concentrates for cooling systems free of light metal	138	8.8	Coolant circuits contaminated with bacteria, fungi or yeast	155
7.5.2	Antifreeze – Ready mixtures for cooling systems free of light metals	141	9	Cleaning the Product Externally	
7.6	Coolant Additives with Limited Series Approval	145	9.1	General information	156
7.6.1	Antifreeze – Concentrates and ready mixtures on ethylene-glycol basis for engines with and without light metal	145	9.2	Approved cleaning agents	157
			10	Revision Overview	
			10.1	Revision overview from version A001064/13 to version A001064/14	158
			11	Index	
			11.1	Index	160

1 Preface

1.1 General information

These Fluids and Lubricants Specifications contain general instructions for the proper and safe operation of your product from the manufacturer Rolls-Royce Solutions.

Symbols and presentation

The following instructions are highlighted in the text and must be observed:

Important

This field contains product information which is important or useful for the user. It refers to instructions, work, and activities that have to be observed to prevent material damage or destruction.

Note:

A note provides special instructions that must be followed when performing a task.

Fluids and lubricants

The useful life, operational reliability, and function of the drive units largely depend on the fluids and lubricants used. The correct selection and treatment of these fluids and lubricants are therefore extremely important. This publication specifies which fluids and lubricants must be used.

mtu ValueCare Portfolio

Rolls-Royce Solutions offers approved oils and coolants tailored to the specific engine under the mtu ValueCare agreement.

Test standards for fluids and lubricants

Test standard	Designation
DIN	Deutsches Institut für Normung (Federal German Standards Institute)
EN	Europäische Normung (European Standards)
ISO	International Standards Organization
ASTM	American Society for Testing and Materials
IP	Institute of Petroleum

Monitoring fluids and lubricants

The maintenance of fluids and lubricants includes regular monitoring. Relevant information on how samples should be taken and handled for laboratory use can be found in the Customer Information "Taking and handling samples for laboratory analyses" (publication number A001080/..). The most recent version can be retrieved from:

<http://www.mtu-solutions.com>

Your contact will be happy to help you with any inquiries.

Applicability of this document

These Fluids and Lubricants Specifications apply to fluids and lubricants for diesel engine-generator sets with the following engines:

- Series 2000Gx5
- Series 2000Gx6
- Series 4000Gx3, application groups 3B, 3D, 3E, 3F, 3G
- Series 4000Gx4
- Series 4000Gx5

Note: References to other engine series in this document should be disregarded.

Document versioning

The Fluids and Lubricants Specifications are revised or supplemented as necessary. Before using them, make sure you have the latest version (publication number A001064/..). The latest specifications are available at: <http://www.mtu-solutions.com>.

Warranty

Use of the approved fluids and lubricants, either under the brand name or in accordance with the specifications given in this publication, constitutes part of the warranty conditions.

The supplier of the fluids and lubricants is responsible for the worldwide standard quality of the named products.

Important

Fluids and lubricants for diesel engine-generator sets can be hazardous materials. Certain regulations must be observed when handling, storing, and disposing of these substances.

These regulations are contained in the manufacturers' instructions, statutory regulations, and technical guidelines valid in the individual countries. Great differences can apply from country to country, and a generally valid statement on applicable regulations is therefore not possible within these Fluids and Lubricants Specifications.

Users of the products named in these specifications are therefore obliged to inform themselves of the locally applicable regulations. Rolls-Royce Solutions accepts no liability whatsoever for improper or illegal use of the fluids and lubricants which it has approved.

Rolls-Royce Solutions recommends consultation with the suppliers of all fluids and lubricants to request the relevant safety data sheets prior to storing, handling and using these fluids and lubricants.

Safe disposal

Important

To prevent environmental pollution and infringements of statutory requirements, used fluids and lubricants must be disposed of in accordance with local regulations.
Do not dispose of or burn the used oil in the fuel tank.

The regulations for the disposal of fluids and lubricants differs from place to place. Environmental protection is one of the fundamental corporate objectives of Rolls-Royce Solutions. We therefore recommend recycling fluids and lubricants wherever possible. If recycling is not available, Rolls-Royce Solutions recommends contacting the local waste disposal authority before disposing of any fluids and lubricants to determine the best option. Users of the products named in these specifications are therefore obliged to inform themselves of the locally applicable regulations. Rolls-Royce Solutions accepts no liability whatsoever for improper or illegal use of the fluids and lubricants which it has approved.

Registered trademarks

All brand names are registered trademarks of the manufacturer concerned.

Preservation

The document “Preservation and Rereservation Specifications” (publication number A001070/..) contains all information on:

- Preservation
- Rereservation and dereservation
- Permissible preservatives

The latest specifications are available at: <http://www.mtu-solutions.com>.

2 Lubricants

2.1 Engine oils – General information

Important
Dispose of used fluids and lubricants in accordance with local regulations.
Used oil must never be disposed of via the internal combustion engine.

Requirements for the approval of engine oils by Rolls-Royce Solutions

The conditions of Rolls-Royce Solutions for the approval of engine oils for diesel engines are defined in the delivery standards and available under these numbers:

- MTL 5044: Engine oils for diesel engines; requirements
- MTL 5051: Initial operation and corrosion inhibitor oil for internal preservation of engines

Engine oil manufacturers are notified in writing if their product is approved.

Approved diesel engine oils are divided into the following quality groups:

- Oil category 1: Standard quality/Single and multi-grade oils
- Oil category 2: Higher quality/Single and multi-grade oils
- Oil category 2.1: Multi-grade oils with a low ash-forming additive content (low SAPS oils)
- Oil category 3: Highest quality/Multi-grade oils
- Oil category 3.1: Multi-grade oils with a low ash-forming additive content (low SAPS oils)

Low SAPS oils are oils with a low sulfur and phosphor content and an ash-forming additive content of $\leq 1\%$.

They are only approved if the sulfur content in the fuel does not exceed 50 mg/kg. When using diesel particulate filters, it is advisable to use these oils to avoid fast coating of the filter with ash particles.

Selection of a suitable engine oil is based on fuel quality, projected oil service life and on-site climatic conditions. At present there is no international industrial standard which alone takes into account all these criteria.

Important
The use of engine oils that are not approved by Rolls-Royce Solutions can lead to a failure in being able to meet statutory emission limits. This can be a punishable offense.

Important
Mixing different engine oils is strictly prohibited!
It is possible to change to a different approved oil grade during an oil change. The remaining oil quantity in the engine oil system is insignificant in this regard.
This procedure also applies to the Rolls-Royce Solutions engine oils in Europe, the Middle East, Africa, America and Asia.

Important
When changing to an engine oil in Category 3, note that the improved cleaning effect of these engine oils can result in the loosening of engine contaminants (e.g. carbon deposits).
It may be necessary therefore to reduce the oil change interval and oil filter service life (one time during change).

Special properties

mtu ValueCare engine oils for diesel engines

The following mtu ValueCare single and multi-grade oils are available from Rolls-Royce Solutions in the respective regions:

Manufacturer & sales region	Product name	SAE grade	Oil category	Material number
Rolls-Royce Solutions GmbH Europe Middle East Africa	DEO SAE 15W-40 Ultra	15W-40	2	20 l canister: X00084315 210 l barrel: X00084316
	Diesel Engine Oil DEO SAE 15W-40 ¹⁾	15W-40	2	Product replaced by DEO SAE 15W-40 Ultra
	Power Guard [®] DEO SAE 40	40	2	20 l canister: X00062816 210 l barrel: X00062817
Rolls-Royce Solutions America Inc. Americas	Power Guard [®] SAE 15W-40 Off Highway Heavy Duty	15W-40	2.1	5 gallons: 800133 55 gallons: 800134 IBC: 800135
	Power Guard [®] SAE 40 Off Highway Heavy Duty	40	2	5 gallons: 23532941 55 gallons: 23532942
Rolls-Royce Solutions Asia Pte. Ltd. Asia	Diesel Engine Oil DEO SAE 15W-40	15W-40	2	20 l canister: 64242/P 205 l barrel: 65151/D
Rolls-Royce Solutions Suzhou Co. Ltd. China	Diesel Engine Oil - DEO 15W-40	15W-40	2	20 l canister: 64242/P 205 l barrel: 65151/D
	Diesel Engine Oil - DEO 10W-40	10W-40	2	20 l canister: 60606/P
PT. Rolls-Royce Solutions Indonesia Indonesia	Diesel Engine Oil - DEO 15W-40	15W-40	2	20 l canister: 64242/P 205 l barrel: 65151/D
mtu India Pvt. Ltd. India	DEO SAE 15W-40 ULTRA	15W-40	2	20 l canister: 60333/P 210 l barrel: 60335/D
	Diesel Engine Oil - DEO 15W-40	15W-40	2	20 l canister: 63333/P 205 l barrel: 65151/P
	Diesel Engine Oil - DEO 40	40	2	20 l canister: 73333/P 205 l barrel: 75151/D

¹⁾ = No longer included in the portfolio. Remaining stocks of this product can be used up as long as the shelf life has not expired.

Restrictions for certain applications

- Series 2000 Gx6
- Series 4000 Gx3
- Series 4000 Gx4
- Series 4000 Gx5

Important

Category 1 oils must not be used!

Restrictions when using low SAPS oils

Important

Oil Categories 2.1 and 3.1 may be used if the sulfur content in the fuel does not exceed 50 mg/kg.

Engine oils for engines with exhaust gas aftertreatment (EGAT)

Engines with exhaust gas aftertreatment place special demands on the oils used to guarantee the operational reliability and service life of the exhaust system and the engine.

Depending on the technology used for exhaust gas aftertreatment, the following oils can be used.

Exhaust gas technology	Approval for oil category				
	1	2	2.1	3	3.1
Diesel oxidation catalyst without particulate filter	No	No	Yes	No	Yes
SCR system with vanadium catalysts (no particulate filter)	No	No	Yes	No	Yes
SCR system with zeolite catalysts (no particulate filter)	No	No	Yes	No	Yes
Closed particulate filter	No	No	Yes	No	Yes
Combination system SCR+ particulate filter	No	No	Yes	No	Yes

Table 1: Engine oils for engines with exhaust gas aftertreatment (EGAT)

Important
The use of engine oils of categories 1, 2 and 3 with ash-forming additives >1% on systems with EGAT results in a significantly reduced service life of the exhaust gas aftertreatment system and, with particulate filters, increased back pressure.

Important
For EPA Tier 4i or Tier 4 and EU IIIb-certified engines with exhaust gas aftertreatment, only low-ash engine oils of category 2.1 or 3.1 are permitted.

Any existing restrictions based on engine requirements must also be observed.

Selection of viscosity grades

Selection of the viscosity grade is based primarily on the ambient temperature at which the engine is to be started and operated. If the relevant performance criteria are observed, the engines can be operated both with single grade and multi-grade oils, depending on the application. For guide values for the temperature limits of the individual viscosity grades, see (→ Figure 1).

If the temperature is too low, the engine oil must be preheated.

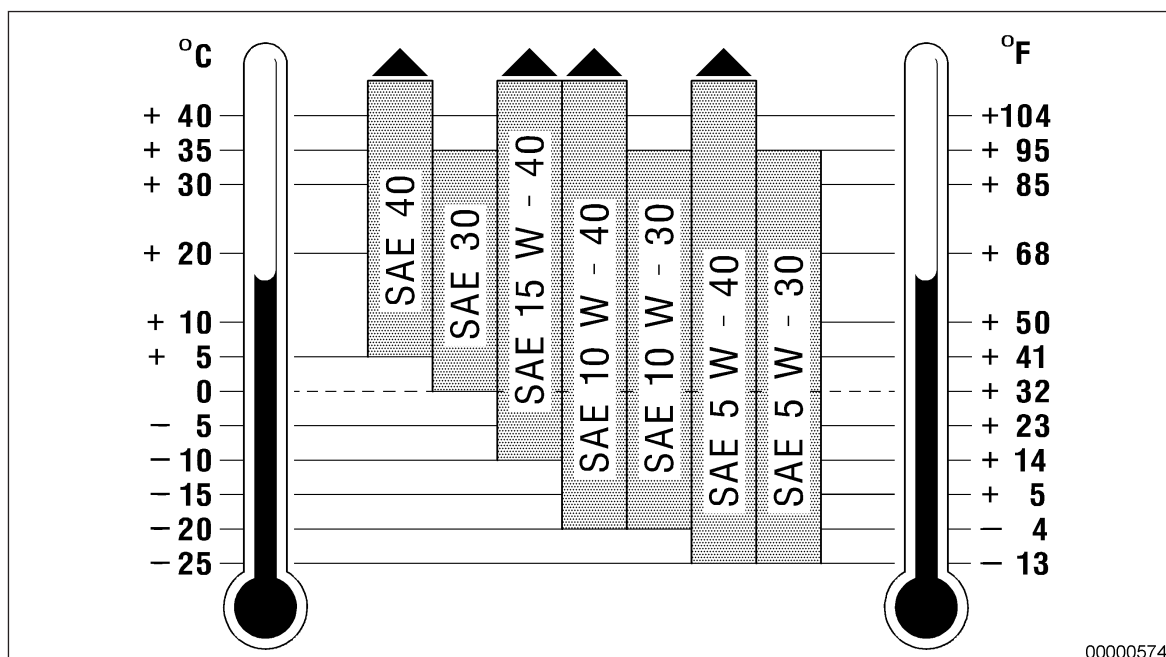

Figure 1: Relationship between viscosity grades and the operating temperature ranges

TIM-ID: 000006085-011

00000574a

Oil service life for diesel engines

Engine oil service life depends on the quality of the engine oil, its conditioning, the operating conditions and the fuel used.

The intervals are guide values based on operational experience and are valid for applications with a standard load profile.

Oil change intervals

Oil category	Without centrifugal oil filter	With centrifugal oil filter or bypass filter
1	250 operating hours	500 operating hours
2	500 operating hours	1,000 operating hours
2.1 ¹⁾	500 operating hours	1,000 operating hours
3	750 operating hours	1,500 operating hours
3.1 ¹⁾	750 operating hours	1,500 operating hours

Table 2: Oil change intervals

¹⁾ = To be used in conjunction with fuels with max. 50 mg/kg sulfur content.

Important

The oil change intervals in the table (→ Table 2) are recommended guidelines when using diesel fuels with <0.5% sulfur content. The defined limit values for the used oil (→ Table 3) must be observed. The oil service life quoted for oils must be confirmed by means of oil analysis.

The oil service life must be determined by oil analysis if one or more of the following difficult operating conditions are encountered:

- Extreme climatic conditions
- High engine startup frequency
- Frequent and prolonged idling or low-load operation
- High fuel sulfur content of 0.5 to 1.5% by weight (see “Use of high-sulfur diesel fuel”)

For applications involving low runtimes, the engine oil must be changed every 2 years at the latest, irrespective of its category.

Where engine oils with higher-grade corrosion-inhibiting characteristics are in use (→ Page 15), a change must be carried out at least every 3 years.

In individual cases, the service life of the engine oil can be optimized by regular laboratory analysis and appropriate engine inspections in consultation with the responsible Rolls-Royce Solutions service point:

- The first oil sample should be taken from the engine as a “basic sample” after the engine has run for approximately 1 hour after being filled with fresh oil.
- Further samples are to be analyzed at specific intervals (see “Laboratory analysis”).
- The appropriate engine inspections are to be carried out before and after the oil analyses.
- After completion of all analyses, and depending on the findings, special agreements can be reached for individual cases.
- Oil samples must always be taken under the same conditions and at the point provided for that purpose (see Operating Instructions).

Special additives

Approved engine oils have been specially developed for diesel engines and have all the properties necessary. Further additives are therefore superfluous and may even be harmful.

Laboratory analysis

Spectrometric oil analysis

Analysis of the engine oil's additive-metal content is carried out by the Rolls-Royce Solutions laboratory to determine the oil brand.

Analyses of the wear-metal content to determine the degree of engine wear are not part of the standard procedure. These content levels are very much dependent on the following factors, among others:

- Engine equipment status
- Tolerance scatter
- Operating conditions
- Load profile
- Fluids and lubricants
- Assembly materials

Unambiguous conclusions as to the wear status of the engine components involved are therefore not possible. This means that no limit values can be provided for wear-metal contents.

The measurement of the wear-metal element contents can only be regarded as a monitoring task. A sudden increase is an indication to check/inspect the oil filter. If wear particles are found, an EDX analysis can determine their qualitative composition, which helps to identify the affected component.

Used-oil analysis

In order to check the used oil, it is recommended that regular oil analyses be carried out. Oil samples should be taken and analyzed at least once per year and during each oil change and under certain conditions, depending on application and the engine's operating conditions, sampling/analysis should take place more frequently.

The specified test methods and limit values (Analytical limit values for used diesel engine oils (→ Table 3)) indicate when the results of an individual oil sample analysis are to be regarded as abnormal.

An abnormal result requires immediate investigation and remedy of the abnormal operating state found.

The limit values relate to individual oil samples. When these limit values are reached or exceeded, an immediate oil change is recommended. The results of the oil analysis do not necessarily give an indication of the wear status of particular components.

In addition to the analytical limit values, the engine condition, its operating state and any operational faults are decisive factors with regard to oil changes.

Some of the signs of oil deterioration are:

- Abnormally heavy deposits or precipitates in the engine or engine-mounted parts such as oil filters, centrifugal filters or separators, especially in comparison with the previous analysis
- Abnormal discoloration of components

Analytical limit values for used diesel engine oils

Characteristic of the engine oil	Test method	Limit values	
Viscosity at 100 °C Max. mm ² /s	ASTM D445 DIN 51562 DIN 51659-1 DIN 51659-2 DIN 51659-3	SAE 30 SAE 5W-30 SAE 10W-30	15.0
		SAE 40 SAE 5W-40 SAE 10W-40 SAE 15W-40 SAE 20W-40	19.0

TIM-ID: 000060865 - 011

Characteristic of the engine oil	Test method	Limit values
Min. mm ² /s		SAE 30 SAE 5W-30 SAE 10W-30
		SAE 40 SAE 5W-40 SAE 10W-40 SAE 15W-40 SAE 20W-40
Flashpoint °C (COC)	ASTM D92 DIN EN ISO 2592	Min. 190
Flashpoint °C (PM)	ASTM D93 DIN EN ISO 2719	Min. 140
Soot content (% by weight)	DIN 51452 CEC-L-82-97	Max. 3.0 (oil category 1) Max. 3.5 (oil category 2, 2.1, 3 and 3.1)
Total base number (mg KOH/g)	ASTM D2896 ISO 3771 DIN 51639	Min. 50% of fresh-oil value
Water content (mg/kg)	ASTM D6304 EN 12937 ISO 6296	Max. 2,000
Oxidation (A/cm ¹)	DIN 51453 ¹⁾	Max. 25
Ethylene glycol (mg/kg)	ASTM D2982	Max. difference between fresh-oil value and used-oil value 100
Additive element contents	DIN 51399-1 DIN 51399-2 ASTM D5158	To confirm that the fresh oil is identical to the used oils

Table 3: Analytical limit values for used diesel engine oils

¹⁾ Only possible if there are no ester compounds

Use of high-sulfur diesel fuel

The following measures must be taken in the case of diesel fuels with a sulfur content above 0.5%:

- Use of an engine oil with a total base number (TBN) of more than 8 mg KOH/g.
- Shorten oil service life (see oil change intervals).
- Series 4000: Shorten TBO (Time Between Overhaul, time between major overhauls) for cylinder head (→ Page 40).

Figure (→ Figure 2) shows the recommended minimum total base numbers for fresh and used oils depending on the sulfur content of the diesel fuel.

For the total base numbers (TBN) of the approved engine oil, see (→ Page 15).

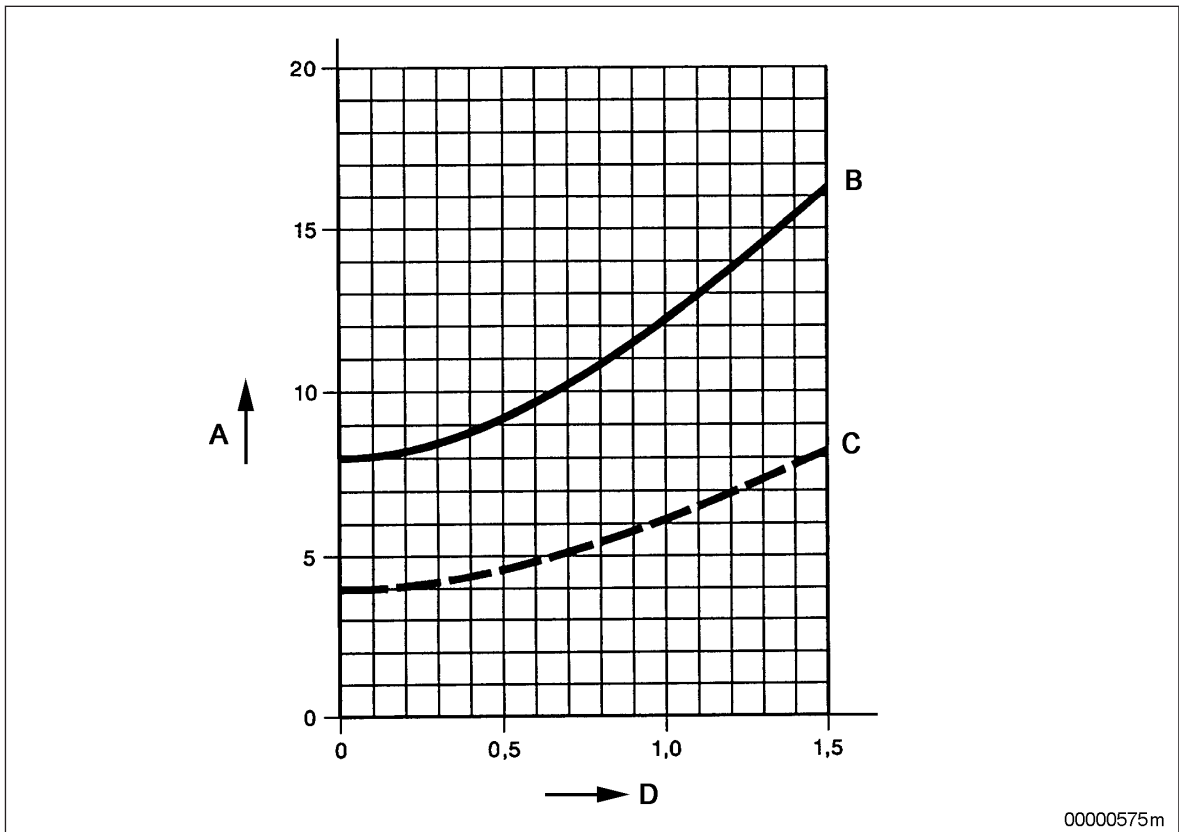

Figure 2: Engine oil total base numbers depending on the diesel fuel's sulfur content

- | | |
|---|--|
| A Total base number in mg KOH/g, ISO 3771 | C Minimum total base number for used oil |
| B Recommended minimum total base number for fresh oil | D Sulfur content of fuel in % by weight |

Use of low-sulfur diesel fuel

The use of diesel fuels with low sulfur content (<0.5%) has no effect on the oil service life.

Minimum requirements for operational checks

Oil analyses can be carried out using the test kit, which contains all the equipment required as well as instructions for use.

Important

Rolls-Royce Solutions recommends the diesel engine test kit from CMT-Technologie GmbH (<https://www.cmttechnologies.de>).

The following analyses can be conducted:

- Determination of oil dispersancy (spot test)
- Determination of diesel fuel content in the oil
- Determination of water content in oil

Test package for North America

The mtu Advanced Fluid Management System, which contributes to preventive maintenance through innovative diagnostics, is available in North America.

For the mtu Advanced Fluid Management System for engine oils, see (→ Page 18).

2.2 Series-based usability for engine oils

Series-based usability of engine oils by the oil categories

Series	Approved engine oils		
	Oil category 1	Oil category 2 and 2.1 (Low SAPS oils)	Oil category 3 and 3.1 (Low SAPS oils)
2000Gx5	<ul style="list-style-type: none"> • Single-grade oils (→ Page 83) • Multigrade oils (→ Page 85) 	<ul style="list-style-type: none"> • Single-grade oils (→ Page 86) • Multigrade oils (→ Page 90) • Multigrade oils (Low SAPS) (→ Page 103) 	<ul style="list-style-type: none"> • Multigrade oils (→ Page 110) • Multigrade oils (Low SAPS) (→ Page 115)
2000Gx6	Not approved	<ul style="list-style-type: none"> • Single-grade oils (→ Page 86) • Multigrade oils (→ Page 90) • Multigrade oils (Low SAPS) (→ Page 103) 	<ul style="list-style-type: none"> • Multigrade oils (→ Page 110) • Multigrade oils (Low SAPS) (→ Page 115)
4000Gx3	Not approved	<ul style="list-style-type: none"> • Single-grade oils (→ Page 86) • Multigrade oils (→ Page 90) • Multigrade oils (Low SAPS) (→ Page 103) 	<ul style="list-style-type: none"> • Multigrade oils (→ Page 110) • Multigrade oils (Low SAPS) (→ Page 115)
4000Gx4	Not approved	<ul style="list-style-type: none"> • Single-grade oils (→ Page 86) • Multigrade oils (→ Page 90) • Multigrade oils (Low SAPS) (→ Page 103) 	<ul style="list-style-type: none"> • Multigrade oils (→ Page 110) • Multigrade oils (Low SAPS) (→ Page 115)
4000Gx5	Not approved	<ul style="list-style-type: none"> • Single-grade oils: Not approved • Multigrade oils: Not approved • Multigrade oils (Low SAPS) (→ Page 103) 	<ul style="list-style-type: none"> • Multigrade oils: Not approved • Multigrade oils (Low SAPS) (→ Page 115)

2.3 Fluorescent dyestuffs for detecting leakage in the lube oil circuit

The fluorescent dyestuffs listed below are approved for detecting leakage in the lube oil circuit.

Manufacturer	Product name	Working concentration	Material number	Container size	Storage stability ¹⁾
Chromatech Europe B.V.	D51000A Chromatint Fluorescent Yellow 175	0.04% - 0.07%	X00067084	16 kg	2 years
Cimcool, Cincinnati	Producto YFD-100	0.5% - 1.0%		5 gallons (canister) 55 gallons (barrel)	6 months

Table 4:

¹⁾ = Ex-works delivery, based on original and hermetically sealed containers in frost-free storage (> 5 °C).

The fluorescence (light-yellow color tone) of both dyestuffs is made visible with a UV lamp (365 nm).

2.4 Lubricating greases

Requirements

The conditions stipulated by Rolls-Royce Solutions for the approval of lubricating greases are specified in the delivery standard MTL 5050, which can be ordered under this reference number.

Lubricating grease manufacturers are notified in writing if their product is approved.

Lubricating greases for general applications

Lithium-saponified greases are to be used for all lubrication points with the exception of:

- Emergency air-shutoff flaps installed between exhaust turbocharger and intercooler (see Special-purpose lubricants)
- Coupling internal centering

Lubricating greases for applications at high temperatures

High-temperature grease (up to 250 °C) must be used for emergency air-shutoff flaps installed between exhaust turbocharger and intercooler:

- Castrol Braycote Inertox 500-2

General purpose greases suffice for emergency air-shutoff flaps installed before the exhaust turbocharger or after the intercooler.

Greases for internal centerings of couplings

Greases for internal centerings:

- Esso Unirex N3 (stable up to approx. 160 °C)

Special-purpose lubricants

Oils for exhaust turbochargers

Exhaust turbochargers with integrated oil supply are generally connected to the engine oil system.

For ABB exhaust turbochargers which are not connected to the engine lube oil system, mineral-based turbine oils with viscosity grade ISO-VG 68 must be used.

Lubricants for curved tooth couplings

Depending on the application, the following lubricants have been approved for curved tooth couplings:

- - Klüber: Structovis BHD MF (highly viscous lube oil)
- - Klüber: Klüberplex GE11-680 (adhesive transmission lubricant)

Guidelines on use and service life of the various lubricants are contained in the relevant Operating Instructions and Maintenance Schedules.

2.5 mtu Advanced Fluid Management System for engine oils – Test package for North America

A sophisticated system for diagnostics and preventive maintenance is available in North America. This system allows the following:

- Optimized oil change intervals
- Extended engine service life
- Detection of minor problems before they become major problems
- Maximization of diesel engine-generator set's reliability
- Higher resale value of diesel engine-generator set

For full information on the mtu Advanced Fluid Management System available in North America, please contact an authorized Rolls-Royce Solutions service partner.

The following test packages from mtu Advanced Fluid Management System can be ordered from authorized Rolls-Royce Solutions service partners in North America:

- BMP32
Extended test – monitoring of wear and contamination
- AMP51R
Extended Test Plus – extension of the oil change intervals

The following engine oil parameters can be determined:

Engine oil parameters	BMP32	AMP51R
24 elementary metals *	✓	✓
percent water *	✓	✓
Viscosity at 40 °C for ISO engine oils	✓	✓
Viscosity at 100 °C for SAE engine oils	✓	✓
Percent fuel dilution **	✓	✓
Percent soot **	✓	✓
Oxidation/nitration	–	✓
Total base number **	–	✓
Total acid number	–	✓

* Samples of non-engine oils submitted with Order No. BMP32, are only examined spectrometrically for metals and the proportion of water and viscosity are determined.

** Samples of non-engine oils submitted with Order No. AMP51R are not examined for fuel dilution, soot content and base number.

The mtu Advanced Fluid Management System with trend analysis provides information for maximizing system reliability. The following guidelines must be followed to obtain the best results.

Samples must be taken:

- While the engine is operating under normal conditions or immediately after stopping the engine while the engine is still at operating temperature
- Every 250 hours at the same point
- By means of suction pump via dipstick tube or sampling cock in filter return

Note: The software offered by Rolls-Royce Solutions for online reporting with trend analyses shows the procedure for optimizing evaluation of the gathered information after completion of the analysis.

Note: The mtu Advanced Fluid Management System works together with independent test laboratories accredited according to ISO 17025 A2LA. This accreditation is the highest level of quality obtainable by a test laboratory in North America.

3 Coolants

3.1 Coolants – General information

Coolant

Definition

Coolant = Coolant additive (concentrate) + freshwater in a predefined mixing ratio
Ready for use in engine

The corrosion-inhibiting effect of coolant is only ensured with the coolant circuit fully filled.

Apart from that, only the corrosion inhibitors approved for internal preservation of the coolant circuit provide proper corrosion protection when the medium was drained. This means that after draining the coolant the cooling circuit must be preserved if no more coolant is to be filled. The procedure is described in the Preservation and Represervation Specifications (publication number A001070/..).

The residual volume of corrosion inhibitor for internal preservation of the cooling circuit that remains for technical reasons when the engine is drained is unproblematic if it is carried over into the subsequently filled, approved coolant. A prerequisite is that it is preserved as standard with PII3/PII3 Frost Protection. If an emulsion is used, a flushing procedure is required.

Coolants must be prepared from suitable freshwater and a coolant additive approved by Rolls-Royce Solutions. Preparation of the coolant must take place outside the engine.

Important

Mixtures of various coolant additives and supplementary additives (also in coolant filters and filters downstream of system components) are not permitted!

The conditions for the approval of coolant additives are specified in the following delivery standards (MTL):

- MTL 5047: Emulsifiable corrosion inhibitor oil
- MTL 5048: Antifreeze
- MTL 5049: Water-soluble corrosion inhibitor

Coolant manufacturers are notified in writing if their product is approved.

Preventing damage to cooling system

- When refilling (following loss of coolant), ensure that not only water but also concentrate is added. The specified antifreeze and/or corrosion inhibitor concentration must be attained.
- Flushing with water is required at every change to a different coolant product. For flushing and cleaning specifications for engine coolant circuits, see (→ Page 148).
- Do not exceed an antifreeze concentration of 55% by volume (max. antifreeze) corrosion inhibitor. Concentrations in excess of this diminish antifreeze protection and heat dissipation.
- The coolant must not contain any oil or copper residue (in solid or dissolved form).
- The majority of corrosion inhibitors currently approved for internal coolant circuit preservation are water-soluble and do not provide antifreeze protection. Make sure that preserved engines are stored safe from frost, because a certain amount of coolant remains in the engine after draining.
- A coolant circuit can usually not be drained completely, i. e. residual quantities of used coolant or freshwater from a flushing procedure remain in the engine. These residual quantities can result in the dilution of a coolant to be filled (mixed from a concentrate or use of a ready mixture). This dilution effect is higher the more attachments there are on the engine. Check the coolant concentration in the coolant circuit and adapt it if necessary.

Important

All coolants approved in these Fluids and Lubricants Specifications generally relate only to the coolant circuit of mtu engines. In the case of complete drive plants, the operating fluids approvals of the component manufacturer must be observed!

Important

To avoid corrosion, it is not permissible to operate an engine with pure water without the addition of an approved corrosion inhibitor!

Special properties

mtu ValueCare – Coolants and premixes

The following ValueCare products have been removed from the portfolio at Rolls-Royce Solutions:

Manufacturer & sales region	Product name	Material number
Rolls-Royce Solutions GmbH, Rolls-Royce Solutions Asia Pte. Ltd. Europe Middle East Africa Asia	Antifreeze	
	Coolant AO 100 Antifreeze Concentrate	Remaining stocks of this product can be used up as long as the shelf life has not expired.
	Coolant AS 100 Antifreeze Concentrate	Remaining stocks of this product can be used up as long as the shelf life has not expired.
	Coolant AH 100 Antifreeze Concentrate	Remaining stocks of this product can be used up as long as the shelf life has not expired.
	Coolant AH 50/50 Antifreeze Premix	Remaining stocks of this product can be used up as long as the shelf life has not expired.
	Coolant AH 40/60 Antifreeze Premix	Remaining stocks of this product can be used up as long as the shelf life has not expired.
	Coolant AH 35/65 Antifreeze Premix	Remaining stocks of this product can be used up as long as the shelf life has not expired.
	Coolant without antifreeze	
	Coolant CS 100 Corrosion Inhibitor Concentrate	Remaining stocks of this product can be used up as long as the shelf life has not expired.
	Coolant CS 10/90 Corrosion Inhibitor Premix	Remaining stocks of this product can be used up as long as the shelf life has not expired.

The products from Rolls-Royce Solutions America Inc. are still available.

Manufacturer & sales region	Product name	Material number
Rolls-Royce Solutions America Inc. Americas	Antifreeze	
	Power Cool® Off-Highway Coolant 50/50 Premix	23533531 (5 gallons) 23533532 (55 gallons)
	Power Cool® Universal 50/50 mix	800069 (1 gallon) 800071 (5 gallons) 800084 (55 gallons)
	Power Cool® Universal 35/65 mix	800085 (5 gallons) 800086 (55 gallons)
	Power Cool® 3149 Concentrate	23528572 (55 gallons) 23528571 (1,000 l)
	Coolant without antifreeze	
	Power Cool® Plus 6000 Concentrate	23533526 (1 gallon) 23533527 (5 gallons) Colored green

Note

For ready mixtures, the percentage of coolant additive (concentrate) is always named first.

Example:

- Coolant AH 40/60 Antifreeze Premix = 40% by volume coolant additive/60% by volume freshwater

Notes on mtu ValueCare coolants

Important
The production and distribution of the coolant CS 100 and CS10/90 will be discontinued by Rolls-Royce Solutions for operational reasons.

The alternative products listed in table (→ Table 5) are compatible when refilling and in the presence of residual quantities when changing coolant.

For all other coolants specified in the Fluids and Lubricants Specifications, refilling is not permitted and flushing is necessary when changing the coolant brand.

mtu ValueCare – Product name	Alternative products	Manufacturer
Coolant CS 100 Corrosion Inhibitor Concentrate	Power Cool® Plus 6000	Rolls-Royce Solutions America Inc.
	Drewgard XTA	Drew Marine
	Zerex G-93	Valvoline
	OEM Advanced 93	Valvoline
	York 719	YORK SAS
Coolant CS 10/90 Corrosion Inhibitor Premix	No alternative ready mixture available. CS 100 concentrate must be prepared with appropriate freshwater.	

Table 5:

Important
The production and distribution of the coolant AH 100, and ready mixtures based on it, will be discontinued by Rolls-Royce Solutions for operational reasons.

The alternative products listed in table (→ Table 6) are compatible when refilling and in the presence of residual quantities when changing coolant.

The products listed in table (→ Table 6) are based on the latest knowledge available at the time of publication of the Fluids and Lubricants Specifications.

For all other coolants specified in the Fluids and Lubricants Specifications, refilling is not permitted and flushing is necessary when changing the coolant brand.

mtu ValueCare – Product name	Alternative products	Manufacturer
Coolant AH 100 Antifreeze Concentrate	NAPA Premium Kühlerschutz N48	Alliance Automotive Service GmbH
	Glysantin G48 blue green	BASF SE
	Tectrol Coolprotect	BayWa AG
	Castrol Radicool NF	Castrol
	CAR 1 Premium Longlife Kühlerschutz C48	COPARTS Autoteile GmbH
	AVIATICON Finkofreeze F48	Finke Mineralölwerk GmbH
	Maintain Fricofin	Fuchs SE
	Titan Fricofin	
	Alpine C48	Mitan Mineralöl GmbH
	MOFIN Kühlerschutz M48 Premium Protect	MOFIN Deutschland GmbH & Co KG
	Mobil Antifreeze Extra	Moove Lubricants Limited
	Nalcool NF48 C	Nalco Water An Ecolab Company
	Roxor Anti-Frost MT-325	LAEMMLE Chemicals AG
	Antifreeze Long Life NF-300 Concentrate	Raloy Lubricantes
	Glacelf MDX	Total Lubrifiants
Zerex-G48	Valvoline	
OEM Advanced 48		
Coolant AH 35/65 Antifreeze Premix	Power Cool® Universal 35/65 mix	Rolls-Royce Solutions America Inc.
Coolant AH 40/60 Antifreeze Premix	Castrol Radicool NF Premix (45%)	Castrol
	Coolelf MDX -26 °C	Total Lubrifiants

mtu ValueCare – Product name	Alternative products	Manufacturer
Coolant AH 50/50 Antifreeze Premix	Power Cool®Universal 50/50 mix	Rolls-Royce Solutions America Inc.
	XTAR Super Coolant Hybrid NF 50%	Cepsa Comercial Petróleo S.A.U.
	AVIATICON Finkofreeze F48 RM 50/50	Finke Mineralölwerk GmbH
	Maintain Fricofin 50	Fuchs SE
	Titan Fricofin 50	
	Mobil Coolant Extra Ready -36 °C	Moove Lubricants Limited
	Antifreeze Long Life NF-300 Ready-to-use (50:50)	Raloy Lubricantes
	Coolelf MDX -37 °C	Total Lubrifiants
	Zerex G-48 premix 50%	Valvoline
	OEM Advanced 48 premix 50%	

Table 6:

Important
The production and distribution of the coolant AO, and ready mixtures based on it, will be discontinued by Rolls-Royce Solutions for operational reasons.

The alternative products listed in table (→ Table 7) are compatible when refilling and in the presence of residual quantities when changing coolant.

The products listed in table (→ Table 7) are based on the latest knowledge available at the time of publication of the Fluids and Lubricants Specifications.

For all other coolants specified in the Fluids and Lubricants Specifications, refilling is not permitted and flushing is necessary when changing the coolant brand.

mtu ValueCare – Product name	Alternative products	Manufacturer
Coolant AO 100 Antifreeze Concentrate	Antifreeze APN-S	Avia AG
	Glystantin G30 pink	BASF SE
	Glystantin G30 ECO pink BMB 100	
	Drewgard ZX	Drew Marine
	AVIATICON Finkofreeze F30	Finke Mineralölwerk GmbH
	Maintain Fricofin G12 Plus	Fuchs SE
	Titan Fricofin G12 Plus	
	Alpine C30	Mitan Mineralöl GmbH
	Omera Premium Coolant	MJL Bangladesh Ltd.
	Zerex G-30	Valvoline
OEM Advanced 30		

Table 7:

Important
The production and distribution of the coolant AS, and ready mixtures based on it, will be discontinued by Rolls-Royce Solutions for operational reasons.

The alternative products listed in table (→ Table 8) are compatible when refilling and in the presence of residual quantities when changing coolant.

The products listed in table (→ Table 8) are based on the latest knowledge available at the time of publication of the Fluids and Lubricants Specifications.

For all other coolants specified in the Fluids and Lubricants Specifications, refilling is not permitted and flushing is necessary when changing the coolant brand.

mtu ValueCare – Product name	Alternative products	Manufacturer
Coolant AS 100 Antifreeze Concentrate	Glysantin G40 pink	BASF SE
	Glysantin G40 ECO pink BMB 100	
	AVIATICON Finkofreeze F30	Finke Mineralölwerk GmbH
	Maintain Fricofin DP	Fuchs SE
	Titan Fricofin DP	
	Roxor Anti-Frost MT-650	LAEMMLE Chemicals AG
	MOFIN Kühlerschutz M40 Extra	MOFIN Deutschland GmbH & Co KG
	Puma HD Hybrid Coolant	Puma Energy International S.A.
	Zerex G-40	Valvoline
	OEM Advanced 40	

Table 8:

3.2 Unsuitable materials in the coolant circuit

Components made of copper, zinc and brass materials

Unless various preconditions are observed, components made of copper, zinc and brass materials in the coolant circuit can cause an electrochemical reaction in conjunction with base metals (e.g. aluminum). As a result, components made of base metals are subject to corrosion or even corrosive pitting. The coolant circuit becomes leaky at these points.

Requirements

Based on current knowledge, the following materials and coatings must not be used in an engine coolant circuit because negative mutual reactions can occur even with approved coolant additives.

Metallic materials

- No galvanized surfaces
The entire cooling system must be free of zinc components. This also applies to coolant supply and drain lines as well as to storage containers
- No copper-based alloys as material with the use of coolant containing nitrite, with the exception of the following two alloys:
 - CuNi10Fe1Mn corresponds to CW-352-H
 - CuNi30Mn1Fe corresponds to CW-354-H
- Do not use components containing brass in the coolant circuit (e.g. coolers made of CuZn30) if exposed to ammoniacal solutions (e.g. amines, ammonium, ...) and solutions containing nitrite or sulfide. Stress-corrosion cracking is possible in the presence of tensile stress and a critical potential area. "Solutions" refer to cleaning agents, coolants and similar substances.
- Avoid copper materials wherever possible or keep their effective surface area to the bare minimum. If copper materials cannot be avoided, purely organically inhibited coolants from the list of approved coolants should be used wherever possible.

Non-metallic materials

- Do not use EPDM or silicone elastomers if emulsifiable corrosion inhibitor oils are used or other oils are introduced to the coolant circuit.

Coolant filter / filter downstream of plant components

- If such filters are used, only products that do not contain additives may be used.
Supplementary additives such as silicates, nitrites etc. can diminish the protective effect or useful life of a coolant and, possibly, attack the materials installed in the coolant circuit.

Information:

Consult the relevant Rolls-Royce Solutions specialist department in case of doubt about the use of materials on the engine / externally mounted components in coolant circuits.

3.3 Requirements imposed on freshwater

For preparation of coolant with and without antifreeze:

Only clean, clear water with values in accordance with those in the following table must be used for preparing the coolant. If the limit values for the water are exceeded, de-mineralized water can be added to reduce the hardness or mineral content.

Parameters	Minimum	Maximum
Sum of alkaline earth metals *) (Water hardness)	0 mmol/l 0°d	2.7 mmol/l 15°d
pH value at 20 °C	5.5	8.0
Chloride ions + fluoride ions		100 mg/l
Sulphate ions		100 mg/l
Anions total		200 mg/l
Bacteria		10 ³ CFU (colony forming unit)/ml
Fungi, yeasts	are not permitted!	

*) Common designations for water hardness in various countries:

1 mmol/l = 5.6°d = 100 mg/kg CaCO₃

- 1°d = 17.9 mg/kg CaCO₃, USA hardness
- 1°d = 1.79° French hardness
- 1°d = 1.25° English hardness

3.4 Emulsifiable corrosion-inhibiting oils

Emulsifiable corrosion-inhibiting oils must not be used with the following Series:

- Series 2000
- Series 4000

Special approval presently in effect remain valid.

3.5 Antifreeze

The previous versions of these Fluids and Lubricants Specifications used the term “Corrosion-inhibiting anti-freeze”. The term “Antifreeze” is now used in this edition for reasons of clarity.

Antifreeze is necessary for engines without heating facilities and for operation in areas where below-freezing temperatures may occur.

The BASF SE Glystantin G206 product for Arctic regions is no longer available. Stocks of this product may be used up as long as the shelf life has not expired. Please contact your Rolls-Royce Solutions partner.

Most of the antifreezes approved by Rolls-Royce Solutions are based on ethylene glycol.

Approved antifreezes based on propylene glycol are listed in the relevant chapter (→ Page 147).

Provided that they are used in approved concentrations, antifreezes approved by Rolls-Royce Solutions provide effective protection against corrosion, see section “Operational monitoring” (→ Page 31).

The antifreeze concentration must be determined not only in accordance with the minimum anticipated temperatures but also with the corrosion protection requirements.

Important

For approved coolant additives for the individual engine series, refer to chapter “Approved coolants” (→ Page 124).

Special approvals presently in effect remain valid.

Important

Coolant additives containing nitrite must not be used in conjunction with coolers that contain brass!

Marine engines are subject to the following limitations when using antifreezes:

Series 538, 595 and 8000:

The use of antifreezes is not allowed for these engines.

Series 956-01, 956-02, 1163-02, 1163-03, 1163-04:

These engines are equipped with heating units. Because of their cooler capacity, antifreezes must not be used.

Series 099, 183, 396:

Antifreezes may be used with these engines at seawater temperatures up to a maximum of 20 °C max.

Series 2000 and 4000:

On these engines with installed heat exchanger, antifreezes may be used at seawater temperatures up to a maximum of 25 °C. The use of antifreezes is generally allowed on engines with no installed heat exchanger. Ensure that the heat exchanger not installed on the engine is sufficiently dimensioned.

The specified maximum values for the seawater temperatures apply to all engines on a vessel that are cooled with seawater, e.g. drive motor and onboard power generator.

Important

The maximum admissible antifreeze content for Series 2000, model types 00 to 07 in marine applications is limited to 40% by volume.

The possibility of using antifreezes for the above-mentioned series for other applications (e.g. genset, rail) is described in the overview in the chapter “Approved coolants” (→ Page 124).

Note:

Propylene glycol-based antifreezes are stipulated for use in some types of applications. These products have a lower thermal conductivity than the usual ethylene glycol products. This results in a higher temperature level in the engine.

Important

Propylene glycol based coolants (→ Page 147) are approved for Series 4000 model types 01 to 05 used in genset applications.

Restrictions apply to the use of propylene glycol based coolants for various model types in all other Series 4000 applications. See (→ Page 124)

Flushing with water is required at every change to a different coolant product. For preserved engines (new engines, field engines, reserve stock engines, etc.), a flushing run must be carried out prior to filling with engine coolant if the engines were preserved with an emulsifiable corrosion inhibitor. The necessary work is described in the chapter "Flushing and cleaning specifications for engine coolant circuits" (→ Page 148).

3.6 Coolant without antifreeze

The previous versions of these Fluids and Lubricants Specifications used the term “water-soluble corrosion inhibitors”. For reasons of clarity, this publication uses the term “Coolant without antifreeze”. Emulsifiable corrosion inhibitor oils are not covered in this chapter. See chapter “Emulsifiable corrosion inhibitor oils” (→ Page 27)

Coolant without antifreeze is required for higher coolant temperatures and large temperature drops in heat exchangers, e.g. in TB systems (with plate-core heat exchanger) and TE systems in Series 099, 183, 2000, 396 and 4000 engines.

Provided that they are used in adequate concentration, coolants without antifreeze approved by Rolls-Royce Solutions provide effective corrosion protection. The relevant concentration range for use is listed in the section on operational monitoring.

Important

For approved coolant additives for the individual engine series, refer to chapter “Approved coolants” (→ Page 124).

Special arrangements presently in effect remain valid.

Important

Coolant additives containing nitrite must not be used in conjunction with coolers that contain brass!

Flushing with water is required at every change to a different coolant product. For preserved engines (new engines, field engines, reserve stock engines, etc.), a flushing run must be carried out prior to filling with engine coolant if the engines were preserved with an emulsifiable corrosion inhibitor. The necessary work is described in the chapter “Flushing and cleaning specifications for engine coolant circuits” (→ Page 148).

3.7 Operational monitoring

Checking the freshwater and continuous monitoring of the coolant are essential for trouble-free engine operation. Freshwater and coolant must be checked at least once per year and after each filling. Analyses can be carried out using the test kit (→ Table 9), or by an authorized laboratory. The test kit contains all the necessary equipment, chemicals and instructions for use.

Important
Rolls-Royce Solutions recommends the diesel engine test kit from CMT-Technologie GmbH (https://www.cmttechnologies.de).

Table 9:

Analysis	Method for on-site checks (Test kit) (→ Table 9)	Method for lab analysis
Determination of the water hardness	Titration	Determination of the Ca and Mg content by means of ICP and calculation of the hardness in °dH or mmol/l
Determination of the pH value	Litmus paper strips for an appropriate measuring range	ASTM D 1287
Determination of the chloride content	Titration	IC
Determination of the sulfate content	-	IC
Determination of the silicon content	-	ICP
Determination of additive concentration in aqueous coolant solutions	Brix refractometer, compare degree(s) Brix against table (→ Table 12) and read off concentration in % by volume.	Refractometer method DIN 51423, compare Brix degree against table (→ Table 12) and read off % by volume.
Determination of antifreeze concentration	Glycol refractometer, concentration in % by volume can be read off directly	Refractometer method DIN 51423, calculation through refraction index or product-specific factor
Determination of germ total for aqueous media	-	Dip slides (tube with culture medium, e.g. by VWR Prolabo No. 535112D or equivalent) incubation time: 4 days at 30 °C

Table 10: Minimum requirements and methodology for coolant monitoring

The routine check of the coolant in accordance with table (→ Table 10) identifies minimum requirements. If there are noticeable problems with the coolant with regard to

- Appearance (color, clouding, contamination, ...)
- Odor

which are reflected in the results of the specified examinations, a laboratory analysis is recommended (see A001080/.. "Handling of Laboratory Samples"). In case of silicon-containing coolants, the silicon content must generally be checked in the laboratory because no rapid test that can be applied is available.

Orders for freshwater and coolant analysis may be placed with Rolls-Royce Solutions. In particular cases, operational monitoring can cover more checks than those listed in table (→ Table 10). Please contact your Rolls-Royce Solutions partner if necessary.

Important

On Series 4000-04/-05 engines, an additional exhaust gas cooler is installed and the cooling system reacts more sensitively. A regular check of the coolant is therefore very important to ensure trouble-free engine operation. This check must be carried out annually or after 3000 operating hours and every time the coolant is filled.

The concentration, pH value and silicon content (only with coolants that contain Si) must be within the values specified in these Fluids and Lubricants Specifications.

Important

Due to thermal stress of the coolant in plants with preheating, a semi-annual analysis of the coolant is recommended.

Permissible concentrations

	Minimum				Maximum
Emulsifiable corrosion inhibitor oils without antifreeze	1% by volume	–	–	–	2% by volume
Antifreeze on ethylene glycol basis	35% by volume	40% by volume	45% by volume	50% by volume	55% by volume
with antifreeze protection up to*	-20 °C	-25 °C	-31 °C	-37 °C	-45 °C
Antifreeze on propylene glycol-basis	35% by volume	–	–	–	50% by volume
with antifreeze protection up to*	-18 °C	–	–	–	-32 °C

Table 11:

* = Antifreeze specifications determined as per ASTM D 1177.

Note:

Concentration ratios may be subject to certain restrictions depending on the customer, Series, model type and application concerned (refer to the Operating Instructions of the engine).

Operational monitoring for permissible concentrations, coolant without antifreeze

Permissible concentration range	Manufacturer	Product name / brand name	Reading on hand-held refractometer ¹⁾ at 20 °C (= degrees Brix)					
			% by volume	7	8	9	10	11
9 to 11% by volume	Rolls-Royce Solutions	Coolant CS 100 Corrosion Inhibitor Concentrate	3.5	4.0	4.5	5.0	5.5	6.0
		Coolant CS 10/90 Corrosion Inhibitor Premix	3.5	4.0	4.5	5.0	5.5	6.0
	Rolls-Royce Solutions America Inc.	Power Cool® Plus 6000	3.5	4.0	4.5	5.0	5.5	6.0
	BASF SE	Glyscorr G93 green	3.5	4.0	4.5	5.0	5.5	6.0
	CCI Corporation	A 216	4.9	5.6	6.3	7.0	7.7	8.4
	CCI Manufacturing IL Corporation	A 216	4.9	5.6	6.3	7.0	7.7	8.4
	Detroit Diesel Corporation	Power Cool Plus 6000	4.9	5.6	6.3	7.0	7.7	8.4
	Drew Marine	Drewgard XTA	3.5	4.0	4.5	5.0	5.5	6.0
	ExxonMobil	Mobil Delvac Extended Life Corrosion Inhibitor	4.9	5.6	6.3	7.0	7.7	8.4
	Ginouves	York 719	3.5	4.0	4.5	5.0	5.5	6.0
	Old World Industries Inc.	Final Charge Extended Life Corrosion Inhibitor (A 216)	4.9	5.6	6.3	7.0	7.7	8.4
	Valvoline	Zerex G-93	3.5	4.0	4.5	5.0	5.5	6.0
		OEM Advanced 93	3.5	4.0	4.5	5.0	5.5	6.0
7 to 11% by volume	Arteco	Havoline XLI	2.6	3.0	3.4	3.7	4.1	4.4
	Chevron	Delo XLI Corrosion Inhibitor - Concentrate	2.6	3.0	3.4	3.7	4.1	4.4
	Nalco Water An Ecolab Company	Alfloc™ 3443	1.75	2.0	2.25	2.5	2.75	3.0
		Alfloc™ 3477	1.75	2.0	2.25	2.5	2.75	3.0
	Chiron Chemicals Pty. Ltd.	PrixMax RCP	2.6	3.0	3.4	3.7	4.1	4.4
	Total	WT Supra	2.6	3.0	3.4	3.7	4.1	4.4
3 to 4% by volume	ImproChem	Cool-C18	Please use test kit of manufacturer.					
	Nalco Water An Ecolab Company	Nalcool® 2000						

Table 12:

¹⁾ = Concentration determined by means of suitable hand-held refractometer

Calibrate the hand-held refractometer with clean water at coolant temperature. The coolant temperature should be 20 °C. Observe the specifications of the manufacturer.

Operational monitoring of admissible concentrations, ethylene glycol based antifreeze (MEG) / propylene glycol based antifreeze (MPG)

The concentration is determined using a suitable glycol refractometer and direct reading of the scale value in % by volume Care must be taken to read off from the relevant scale when using hand-held refractometers indicating both MEG and MPG scaling.

3.8 Limit values for coolants

pH value when using:			Method
– Emulsifiable corrosion inhibiting oil	Min. 7.5	Max. 9.5	ASTM D 1287, ISO 976
– Antifreeze	Min. 7.5	Max. 9.0	
– Coolant without antifreeze for engines containing light metal	Min. 7.5	Max. 9.0	
– Coolant without antifreeze for engines free of light metal	Min. 7.5	Max. 11.0	

Table 13:

Silicon content in silicon-containing coolants			Method
Silicon	Min. 25 mg/l		ICP

Table 14:

The coolant must be changed in case of non-compliance with the above specifications.

Note:

For a holistic appraisal of a coolant function, apart from the above-mentioned limit values the respective coolant-specific characteristic data and the fresh water quality used must be taken into consideration.

3.9 Coolant concentrates – Storage capability

The storage capability specifications refer to coolant concentrates in original, hermetically sealed packing with storage temperatures up to max. 30 °C.

The instructions of the manufacturer must also be observed.

Coolant concentrate	Limit value	Brand name / Comments
Emulsifiable corrosion inhibitor oil	12 months	Oil 9156
Antifreeze	Approx. 3 years	Observe manufacturer's instructions.
Coolant without antifreeze	2 years	ImproChem Cool-C18 Nalco Nalcool® 2000 PrixMax RCP
	3 years	BASF Glyscorr G93 green Drew Marine Drewgard XTA Ginouves York 719 Rolls-Royce Solutions GmbH Coolant CS100 Rolls-Royce Solutions America inc. Power Cool® Plus 6000 Nalco Alfloc™ 3477 Valvoline ZEREX G-93 Valvoline OEM Advanced 93
	5 years	Arteco Havoline XLI CCI Corporation A216 CCI Manufacturing IL A216 Chevron Delo XLI Corrosion Inhibitor Concentrate Detroit Diesel Corp. Power Cool Plus 6000 ExxonMobil Mobil Delvac Extended Life Corrosion Inhibitor Old World Industries Final Charge Extended Life Corrosion Inhibitor (A216) Total WT Supra

Table 15:

Note:

For reasons of corrosion protection, do not store in galvanized containers. Take this requirement into account when transferring coolant.

Containers must be hermetically sealed and stored in a cool, dry place. Frost protection must be provided in winter.

Further information can be obtained from the product and safety data sheets for the individual coolants.

3.10 Color additives to detect leakage in the coolant circuit

The following listed fluorescent dyes are approved as additives for coolant without antifreeze for the detection of leaks.

Approved color additives

Manufacturer	Product name	Material number	Container size	Storage stability ¹⁾
Chromatech Inc. Chromatech Europe B.V.	D11014 Chromatint Uranine Conc	X00066947	20 kg	2 years

¹⁾ = Based on original and hermetically sealed containers in frost-free storage (> 5 °C)

Table 16:

Application:

Add approx. 40 g of dye per 180 l of coolant.

This dye quantity is already very generous and must not be exceeded.

The fluorescence (yellow tone) is easily recognizable in daylight. UV light with a wavelength of 365 nm can be used in darker rooms.

3.11 mtu Advanced Fluid Management System for coolant – Test package for North America

A sophisticated system for diagnostics and preventive maintenance is available in North America. This system allows the following:

- Optimization of the coolant change intervals
- Evaluation of metal migration
- Evaluation of the coolant's corrosive properties
- Detection of the causes of problems in the cooling system in connection with blown cylinder-head gaskets, electrical ground problems, localized overheating and contaminants within and outside the system

For full information on the mtu Advanced Fluid Management System available in North America, please contact an authorized Rolls-Royce Solutions service partner.

The following test packages from mtu Advanced Fluid Management System can be ordered from authorized Rolls-Royce Solutions service partners in North America:

- C-P92
Basic test – For monitoring the corrosivity of the coolant and for detecting metal migration
- C-P94
Extended test – Identification of the causes of leaks in the combustion system, grounding problems and contamination in the plant
- C-P93
Extended Test Plus – Monitoring of corrosivity and metal migration plus HPLC analysis and IC analysis for confirmation of the determined contamination of the corrosion inhibitor

The following coolant parameters can be determined:

Coolant parameters	C-P92	C-P94	C-P93
15 elementary metals	✓	✓	✓
Glycol percentage	✓	✓	✓
Freezing point	✓	✓	✓
Boiling point	✓	✓	✓
pH value	✓	✓	✓
Total hardness	✓	✓	✓
SCA number	✓	✓	✓
Nitrite	✓	✓	✓
Specific conductivity	✓	✓	✓
Carboxylic acid	✓	✓	✓
Sensory parameters (color, oil, fuel, magnetic precipitation, amagnetic precipitation, odor and foam)	✓	✓	✓
Contamination and corrosion inhibitor through IC (chloride, sulfate, nitrite, nitrate, phosphate and glycolate)	–	✓	✓
HPCL	–	–	✓

The mtu Advanced Fluid Management System with trend analysis provides information for maximizing system reliability. The following guidelines must be followed to obtain the best results.

Samples must be taken:

- While the engine is operating under normal conditions or immediately after stopping the engine while the engine is still at operating temperature
- Every 250 hours at the same point

Note: The software offered by Rolls-Royce Solutions for online reporting with trend analyses shows the procedure for optimizing evaluation of the gathered information after completion of the analysis.

Note: The mtu Advanced Fluid Management System works together with independent test laboratories accredited according to ISO 17025 A2LA. This accreditation is the highest level of quality obtainable by a test laboratory in North America.

4 Liquid Fuels

4.1 Diesel fuels – General information

Important
 Dispose of used fluids and lubricants in accordance with local regulations!
 Used oil must never be disposed of by adding it to the internal combustion engine!

Selecting a suitable diesel fuel

The quality of the fuel is extremely important for satisfactory engine performance, long engine service life and acceptable exhaust emission levels.

Important
 Diesel fuels are not available worldwide in the quality required according to (→ Table 17) and (→ Page 56).
 The fuel properties depend on many factors, in particular, region, time of year, and storage.

Important
 If the fuel is to be stored in storage tanks for an extended period of time, we urgently recommend the use of B0 fuel (biodiesel/FAME-free fuel). This recommendation is supported by a 2015 paper published by the Federal Council for Information Security entitled “New findings on fuel storage life for standby power systems”. This recommendation applies to the use of both fossil and paraffinic diesel fuel. FAME (Fatty Acid Methyl Ester) stands for first generation biodiesel.
 Rolls-Royce Solutions GmbH provides project-specific consultation on request.
 We recommend that you determine the oxidation stability (EN ISO 12205/ASTM D 2274) to check the quality.

Unsuitable fuel usually leads to a reduced useful life of engine components and can also cause engine damage.

Further details on fuel qualities, tank care and filtration are available in the publication “Useful information on fuels, tank systems and filtration” (publication number A060631/..).

Applicable fuel limit values

Characteristics of the fuel		Test method		Limit values
		ASTM		
Composition				The diesel fuel must be free of inorganic acids, visible water, solid foreign matter, and chlorine compounds.
Total contamination (= fuel-insoluble ingredients)	Max.	D6217	EN 12662	24 mg/kg
Density at 15 °C	Min.	D1298	EN ISO 3675	0.820 g/ml
	Max.	D4052	EN ISO 12185	0.860 g/ml

- ¹⁾ See series-specific injection and exhaust gas aftertreatment systems (→ Table 21) for the definition as to whether an exhaust gas aftertreatment system is installed.
- ²⁾ If local legislation permits the use of fuel with a sulfur content > 15 mg/kg. If applicable, the use of fuel with a sulfur content > 15 mg/kg voids compliance with the emissions regulations.
- ³⁾ Note: 1% by weight = 10,000 mg/kg = 10,000 ppm
- ⁴⁾ = Relevant for diesel fuel with a FAME content of ≥ 2% by vol.
- ⁵⁾ = Relevant for diesel fuel with a FAME content of < 2% by vol.

TIM-ID: 0000060900 - 011

Characteristics of the fuel		Test method		Limit values
		ASTM		
API gravity at 60 °F	Min.	D287		41
	Max.			33
Viscosity at 40 °C	Min.	D445	EN ISO 3104	1.5 mm ² /s
	Max.			4.5 mm ² /s
Flashpoint (closed crucible)	Greater	D93	DIN EN ISO 27 19	55 °C
Boiling curve:		D86	EN 17306	
– Initial boiling point				160 to 220 °C
– Volume share at 250 °C	Max.			65% by volume
– Volume share at 350 °C	Min.			85% by volume
– Residue and loss	Max.			3% by volume
Fatty acid methyl ester content (FAME) (“Biodiesel”)	Max.		EN 14078 Internal Rolls-Royce Solutions procedure	7.0% by volume
Water content: (absolute, no free water)	Max.	D6304	EN ISO 12937	200 mg/kg
Carbon residue from 10% distillation residue	Max.	D189	EN ISO 10370	0.30% by weight
Oxide ash: ¹⁾		D482	EN ISO 6245	
– Engines without exhaust gas aftertreatment and without exhaust gas recirculation	Max.			0.01% by weight (100 mg/kg)
– Engines with exhaust gas aftertreatment or with exhaust gas recirculation	Max.			0.001% by weight (10 mg/kg)
Sulfur content: ¹⁾				
– Engines without exhaust gas aftertreatment or without exhaust gas recirculation	Max.	D5453, D2622	EN ISO 20846, EN ISO 20884	0.5% by weight (5,000 mg/kg) ³⁾
– Engines with exhaust gas aftertreatment or with exhaust gas recirculation	Max.			0.0015% by weight (15 mg/kg) ³⁾
Sulfur content: ²⁾				
– Deviating, but approved sulfur content for certain products				
– 2000Gx5 and 2000Gx6	Max.			0.05% by weight (500 mg/kg) ³⁾
Cetane number	Min.	D613	EN ISO 5165, EN ISO 15195	45

¹⁾ See series-specific injection and exhaust gas aftertreatment systems (→ Table 21) for the definition as to whether an exhaust gas aftertreatment system is installed.
²⁾ If local legislation permits the use of fuel with a sulfur content > 15 mg/kg. If applicable, the use of fuel with a sulfur content > 15 mg/kg voids compliance with the emissions regulations.
³⁾ Note: 1% by weight = 10,000 mg/kg = 10,000 ppm
⁴⁾ = Relevant for diesel fuel with a FAME content of ≥ 2% by vol.
⁵⁾ = Relevant for diesel fuel with a FAME content of < 2% by vol.

Characteristics of the fuel		Test method		Limit values
		ASTM		
Cetane index	Min.	D976	EN ISO 4264	42
Copper corrosion 3 hrs at 50 °C	Max. de- gree of cor- rosi- on	D130	EN ISO 2160	1a
Oxidation stability (Rancimat) ⁴⁾	Min.		EN 15751	20 hours
Oxidation stability ⁵⁾	Max.	D2274	EN ISO 12205	25 g/m ³
Lubricity at 60 °C (HFRR value)	Max.	D6079	EN ISO 12156- 1	520 µm
Neutralization number	Max.	D974		0.2 mg KOH/g

¹⁾ See series-specific injection and exhaust gas aftertreatment systems (→ Table 21) for the definition as to whether an exhaust gas aftertreatment system is installed.
²⁾ If local legislation permits the use of fuel with a sulfur content > 15 mg/kg. If applicable, the use of fuel with a sulfur content > 15 mg/kg voids compliance with the emissions regulations.
³⁾ Note: 1% by weight = 10,000 mg/kg = 10,000 ppm
⁴⁾ = Relevant for diesel fuel with a FAME content of ≥ 2% by vol.
⁵⁾ = Relevant for diesel fuel with a FAME content of < 2% by vol.

Table 17: Applicable fuel limit values

Diesel fuels in winter operation

At low outdoor temperatures, diesel fuel fluidity can be inadequate as a result of paraffin precipitation. It is the fuel supplier's responsibility to provide a fuel that will assure correct engine operation at the expected minimum temperatures under the given geographical and other local conditions.

The operating company must ensure that the correct fuel required for the corresponding climatic requirements is always used.

In order to prevent operational problems (e.g. clogged filters) during the winter months, diesel fuel with suitable cold-flow characteristics is available on the market. Deviations are possible during transitional periods and in individual countries.

The following parameters define the cold-flow characteristics:

		Test methods		Limit values
		ASTM		
Cold filter plugging point (CFPP)		D6371	DIN EN 116	See Note ¹⁾
Cloud point		D2500	DIN EN 3015	See Note ²⁾

Table 18: Parameters to define the cold-flow characteristics

¹⁾ Filter plugging point or Cold Filter Plugging Point (CFPP) denotes the temperature at which a test filter is clogged by precipitated paraffins under defined conditions. This characteristic is used for diesel fuels as per DIN EN 590 to describe the climatic requirements (e.g. summer and winter diesel). As a rule, however, the fuel filters installed on the engine have a significantly higher filtration efficiency than the test filters.

²⁾ The cloud point is the temperature at which a liquid product becomes turbid in the test glass due to precipitation of paraffin. This must not be higher than the ambient temperature.

Rolls-Royce Solutions GmbH recommends the use of the cloud point for the evaluation of the cold-flow characteristics.

Use of fuels with higher sulfur content:

The engines are certified for operation with the fuels approved in these Fluids and Lubricants Specifications.

The component TBO specified in the Maintenance Schedule relates to operation of the engine with diesel fuel as per DIN EN 590.

For operation with a high sulfur content in the fuel, the following must be observed:

Series 4000

When a fuel with sulfur content > 3,000 mg/kg is used, the times specified in the Maintenance Schedule for component TBO of the cylinder head may be reduced, see following table (→ Page 43).

TBO cylinder head as a function of sulfur content in the fuel

Sulfur content in fuel (mg/kg)	TBO cylinder head (h)
<3,000	According to Maintenance Schedule
3,000–4,500	7,000 ¹⁾
4,500–5,000	5,000 ¹⁾

Table 19: TBO cylinder head as a function of sulfur content in the fuel

¹⁾ = If the TBO for the cylinder head specified in the Maintenance Schedule is shorter, the shorter TBO shall always apply.

Engines with exhaust gas recirculation and/or exhaust gas aftertreatment must not be operated with excessive sulfur content in the fuel. The limit values in the Fluids and Lubricants Specifications apply.

Important

If the sulfur content in the fuel is > 0.5% by weight (> 5,000 mg/kg), please consult with Rolls-Royce Solutions GmbH (Application).

When engines are operated with diesel fuels with a sulfur content of more than 0.5% by weight, appropriate engine oils must be used. The criteria for the selection of engine oils can be found in the chapter “Engine oils” (→ Page 8).

Note

The limit values named in the table (→ Table 17) must be observed no later than at the interface [(→ Figure 3), item 6] to guarantee safe and efficient engine operation. This applies in particular to water and total contamination.

Important

In addition to the limit values listed in the table (→ Table 17) and (→ Page 60) a particle distribution in the fuel in acc. with ISO 4406 must be observed, see (→ Table 20).

Particle distribution for fuels

Particle distribution	Test method ASTM		Limit values	
			2000 Gx6 4000 Gx3 4000 Gx4 4000 Gx5	2000 Gx5
Particle distribution for fuel between last tank before engine and prefilter [(→ Figure 3), item 5]	D7619 D7647	Coding of number of particles as per ISO 4406	max. ISO Code 18/17/14 for 4/6/14 µm particle size	max. ISO Code 21/20/17 for 4/6/14 µm particle size

Table 20: Particle distribution for fuels

Important

The limit values named in the table (→ Table 20) must already be observed in the feed between the last tank before the engine and the prefilter (if necessary, with water separator).

For plants without a prefilter, this refers to the feed between the last tank and the scope of supply of Rolls-Royce Solutions. For the analysis of the fuel quality, an interface (sample extraction cock) must be provided for sample extraction during operation.

For existing plants without an accessible feed, sample extraction in the last tank before the scope of supply of Rolls-Royce Solutions is permissible.

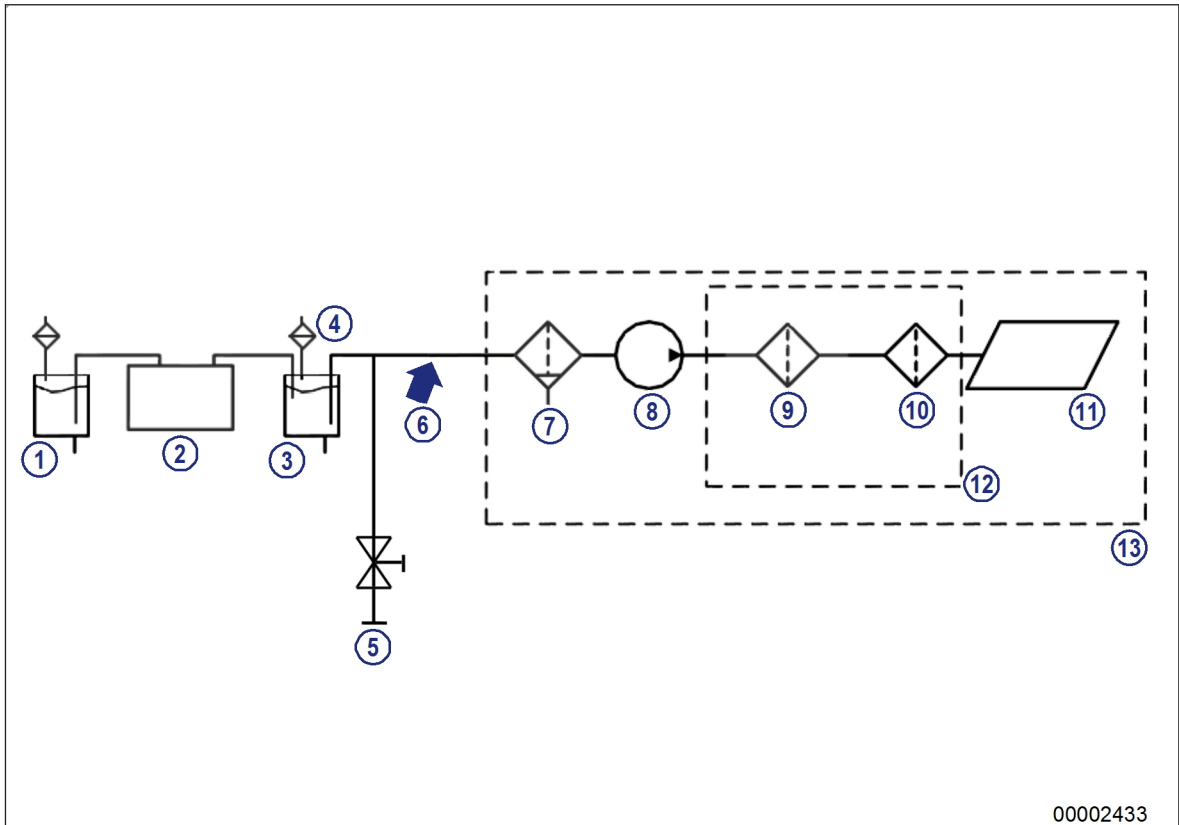

Figure 3: General fuel system diagram for diesel engines

- | | | |
|-----------------------------|--|---------------------------|
| 1 Fuel tank | 6 Interface for fuel specification | 11 Injection system |
| 2 Fuel treatment (optional) | 7 Fuel prefilter with water separator (optional) | 12 Engine filter |
| 3 Last tank before engine | 8 LP fuel pump | 13 Engine scope of supply |
| 4 Tank breather filter | 9 Intermediate filter (optional) | |
| 5 Sampling point | 10 Primary filter | |

Note:

In case of poor particle distribution, it is necessary to integrate further/more optimized filter stages in the fuel system to achieve the operational life of fuel filters and components of the injection system.

For the limit values specified for the interface, it has been validated that prefilters approved by Rolls-Royce Solutions provide sufficient filtration.

Rolls-Royce Solutions shall not provide warranty cover for damage or impairment to engines caused by the following types of use:

- Fuel grades not approved by Rolls-Royce Solutions (see (→ Table 17), (→ Table 20), (→ Page 46))
- Prefilters not approved by Rolls-Royce Solutions

TUM-ID: 000006900-011

Series-based injection and exhaust gas aftertreatment systems (EGAT)

Series	Diesel accumulator injection system (Common Rail)	Conventional injection systems	Exhaust gas aftertreatment system (EGAT)	Exhaust gas recirculation
2000Gx5		Yes	No	No
2000Gx6	Yes		No	No
4000Gx3, Gx4, Gx5	Yes		4000Gx5 only	No

Table 21: Series-based injection and exhaust gas aftertreatment systems (EGAT)

Laboratory analysis

An order for fuel analysis can be placed with Rolls-Royce Solutions.

The following information is required:

- Fuel specifications
- Sampling point
- Serial ID of engine from which fuel sample was taken.

Submit the following:

- 1.0 liters of fuel
- 2.0 liters of fuel (with additional determination of cetane number).

Test package for North America

The mtu Advanced Fluid Management System, which contributes to preventive maintenance through innovative diagnostics, is available in North America.

mtu Advanced Fluid Management System for fuels, see (→ Page 79).

4.2 Series-dependent approval of fuel grades for mtu engines

4.2.1 Distillate fuels according to EN 590 and ASTM D975

Commercially available diesel fuels meeting the following specifications are approved for use:

Approved fuel grades Fuel specifications	Series 2000	
	2000Gx5	2000Gx6
EN 590: 2022-05 <ul style="list-style-type: none"> • Summer and winter quality • Particle distribution in accordance with table "Particle distribution for fuel", see chapter (→ Page 40) 	Approved	Approved
ASTM D975-21 <ul style="list-style-type: none"> • Grade 1-D • S 15, S 500, S 5000 • Density: 0.820 to 0.860 g/ml* • Water content: max. 200 mg/kg • Total contamination: max. 24 mg/kg • Particle distribution in accordance with table "Particle distribution for fuel", see chapter (→ Page 40) 	Approved if: <ul style="list-style-type: none"> • Viscosity min. 1.5 mm²/s • Cetane number min. 45 or cetane index min. 42 • Sulfur content max. 500 mg/kg 	Approved if: <ul style="list-style-type: none"> • Viscosity min. 1.5 mm²/s • Cetane number min. 45 or cetane index min. 42 • Sulfur content max. 500 mg/kg
ASTM D975-21 <ul style="list-style-type: none"> • Grade 2-D • S 15, S 500, S 5000 • Density: 0.820 to 0.860 g/ml* • Water content: max. 200 mg/kg • Total contamination: max. 24 mg/kg • Particle distribution in accordance with table "Particle distribution for fuel", see chapter (→ Page 40) 	Approved if: <ul style="list-style-type: none"> • Cetane number min. 45 or cetane index min. 42 • Sulfur content max. 500 mg/kg 	Approved if: <ul style="list-style-type: none"> • Cetane number min. 45 or cetane index min. 42 • Sulfur content max. 500 mg/kg
* deviating values: Approval possible project-specifically. If the density is too low, this can result in a power reduction. Engine operating values may change as a result of power adjustment.		

Approved fuel grades Fuel specifications	Series 4000	
	4000Gx3	4000Gx4
EN 590: 2022-05 <ul style="list-style-type: none"> • Summer and winter quality • Particle distribution in accordance with table "Particle distribution for fuel", see chapter (→ Page 40) 	Approved	Approved
ASTM D975-21 <ul style="list-style-type: none"> • Grade 1-D • S 15, S 500, S 5000 • Density: 0.820 to 0.860 g/ml* • Water content: max. 200 mg/kg • Total contamination: max. 24 mg/kg • Particle distribution in accordance with table "Particle distribution for fuel", see chapter (→ Page 40) 	Approved if: <ul style="list-style-type: none"> • Viscosity min. 1.5 mm²/s • Cetane number min. 45 or cetane index min. 42 	Approved if: <ul style="list-style-type: none"> • Viscosity min. 1.5 mm²/s • Cetane number min. 45 or cetane index min. 42
ASTM D975-21 <ul style="list-style-type: none"> • Grade 2-D • S 15, S 500, S 5000 • Density: 0.820 to 0.860 g/ml* • Water content: max. 200 mg/kg • Total contamination: max. 24 mg/kg • Particle distribution in accordance with table "Particle distribution for fuel", see chapter (→ Page 40) 	Approved if: <ul style="list-style-type: none"> • Cetane number min. 45 or cetane index min. 42 	Approved if: <ul style="list-style-type: none"> • Cetane number min. 45 or cetane index min. 42
* Deviating values: Approval possible project-specifically. If the density is too low, this can result in a power reduction. Engine operating values may change as a result of power adjustment.		

Approved fuel grades Fuel specifications	Series 4000 4000Gx5
EN 590: 2022-05 <ul style="list-style-type: none"> • Summer and winter quality • Particle distribution in accordance with table “Particle distribution for fuel”, see chapter (→ Page 40) 	Approved
ASTM D975-21 <ul style="list-style-type: none"> • Grade 1-D • S 15, S 500, S 5000 • Density: 0.820 to 0.860 g/ml* • Water content: max. 200 mg/kg • Total contamination: max. 24 mg/kg • With exhaust gas aftertreatment: Max. sulfur content of 15 mg/kg, or is defined series- and application-specifically. • Particle distribution in accordance with table “Particle distribution for fuel”, see chapter (→ Page 40) 	Approved if: <ul style="list-style-type: none"> • Viscosity min. 1.5 mm²/s • Cetane number min. 45 or cetane index min. 42
ASTM D975-21 <ul style="list-style-type: none"> • Grade 2-D • S 15, S 500, S 5000 • Density: 0.820 to 0.860 g/ml* • Water content: max. 200 mg/kg • Total contamination: max. 24 mg/kg • With exhaust gas aftertreatment: Max. sulfur content of 15 mg/kg, or is defined series- and application-specifically. • Particle distribution in accordance with table “Particle distribution for fuel”, see chapter (→ Page 40) 	Approved if: <ul style="list-style-type: none"> • Cetane number min. 45 or cetane index min. 42
* Deviating values: Approval possible project-specifically. If the density is too low, this can result in a power reduction. Engine operating values may change as a result of power adjustment.	

4.2.2 British Standard 2869

Commercially available diesel fuels meeting the following specifications are approved for use:

Approved fuel grades Fuel specification	Series 2000		
	2000Gx5	2000Gx6	
BS 2869:2017 <ul style="list-style-type: none"> Part 1 Class A2 Density: Max. 860 kg/m³ Viscosity: Max. 4.5 mm²/s. If viscosity min. 4.5 mm²/s: Preheating required Particle distribution in accordance with table "Particle distribution for fuel", see chapter (→ Page 40) 	No approval	No approval	
BS 2869:2017 <ul style="list-style-type: none"> Part 2 Class D Density: Max. 860 kg/m³ Viscosity: Max. 4.5 mm²/s. If viscosity min. 4.5 mm²/s: Preheating required Particle distribution in accordance with table "Particle distribution for fuel", see chapter (→ Page 40) 	No approval	No approval	

Approved fuel grades Fuel specifications	Series 4000		
	4000Gx3	4000Gx4	4000Gx5
BS 2869:2017 <ul style="list-style-type: none"> Part 1 Class A2 Density: Max. 860 kg/m³ Viscosity: Max. 4.5 mm²/s. If viscosity min. 4.5 mm²/s: Preheating required With exhaust gas aftertreatment: Max. sulfur content of 15 mg/kg, or is defined series- and application-specifically. Particle distribution in accordance with table "Particle distribution for fuel", see chapter (→ Page 40) 	Approved	Approved	Not approved
BS 2869:2017 <ul style="list-style-type: none"> Part 2 Class D Density: Max. 860 kg/m³ Viscosity: Max. 4.5 mm²/s. If viscosity min. 4.5 mm²/s: Preheating required With exhaust gas aftertreatment: Max. sulfur content of 15 mg/kg, or is defined series- and application-specifically. Particle distribution in accordance with table "Particle distribution for fuel", see chapter (→ Page 40) 	Approved	Approved	Not approved

4.2.3 Chinese distillate fuels according to GB 19147-2016, GB 252-2015 and GB 17411-2016

Commercially available diesel fuels meeting the following specifications are approved for use:

Approved fuels Fuel specifications	Series 2000	
	2000Gx5	2000Gx6
GB 19147-2016 <ul style="list-style-type: none"> • Grade 0 # • III: S max. 350 mg/kg • IV: S max. 50 mg/kg • V: S max. 10 mg/kg • Density: 0.820 to 0.860 g/ml* • Proportion of water: Max. 200 mg/kg • Total contamination: Max. 24 mg/kg • Particle distribution in accordance with table "Particle distribution for fuel", see chapter (→ Page 40) • Neutralization number: Max 0.2 mgKOH/g • Viscosity at 40 °C: 1.5 to 4.5 mm²/s 	Approved	Approved
GB 252-2015 <ul style="list-style-type: none"> • Grade 0 # • Density: 0.820 to 0.860 g/ml* • Proportion of water: Max. 200 mg/kg • Total contamination: Max. 24 mg/kg • Particle distribution in accordance with table "Particle distribution for fuel", see chapter (→ Page 40) • Neutralization number: Max 0.2 mgKOH/g • Viscosity at 40 °C: 1.5 to 4.5 mm²/s 	Approval upon request	Approval upon request
GB 17411-2016 <ul style="list-style-type: none"> • Grade DMX • Density: 0.820 to 0.860 g/ml* • Proportion of water: Max. 200 mg/kg • Total contamination: Max. 24 mg/kg • Particle distribution in accordance with table "Particle distribution for fuel", see chapter (→ Page 40) • Neutralization number: Max 0.2 mgKOH/g • Viscosity at 40 °C: 1.5 to 4.5 mm²/s 	Not approved	Not approved

* deviating values: Approval possible project-specifically. If the density is too low, this can result in a power reduction. In the framework of power readjustment, it is possible that the engine operational values change

Approved fuels Fuel specifications	Series 4000		
	4000Gx3	4000Gx4	4000Gx5
GB 19147-2016 <ul style="list-style-type: none"> • Grade 0 # • III: S max. 350 mg/kg • IV: S max. 50 mg/kg • V: S max. 10 mg/kg • Density: 0.820 to 0.860 g/ml* • Proportion of water: Max. 200 mg/kg • Total contamination: Max. 24 mg/kg • Particle distribution in accordance with table "Particle distribution for fuel", see chapter (→ Page 40) • Neutralization number: Max 0.2 mgKOH/g • Viscosity at 40 °C: 1.5 to 4.5 mm²/s 	Approved	Approved	Not approved
GB 252-2015 <ul style="list-style-type: none"> • Grade 0 # • Density: 0.820 to 0.860 g/ml* • Proportion of water: Max. 200 mg/kg • Total contamination: Max. 24 mg/kg • Particle distribution in accordance with table "Particle distribution for fuel", see chapter (→ Page 40) • Neutralization number: Max 0.2 mgKOH/g • Viscosity at 40 °C: 1.5 to 4.5 mm²/s 	Approved	Approved	Not approved
GB 17411-2016 <ul style="list-style-type: none"> • Grade DMX • Density: 0.820 to 0.860 g/ml* • Proportion of water: Max. 200 mg/kg • Total contamination: Max. 24 mg/kg • Particle distribution in accordance with table "Particle distribution for fuel", see chapter (→ Page 40) • Neutralization number: Max 0.2 mgKOH/g • Viscosity at 40 °C: 1.5 to 4.5 mm²/s 	Approved	Not approved	Not approved

* deviating values: Approval possible project-specifically. If the density is too low, this can result in a power reduction. In the framework of power readjustment, it is possible that the engine operational values change

4.2.4 Heating oil

Commercially available diesel fuels meeting the following specifications are approved for use:

Heating oil

Approved fuels Fuel specifications	Series 2000		
	2000Gx5	2000Gx6	
DIN 51603-1:2020-09, heating oil EL Standard <ul style="list-style-type: none"> • Cetane number min. 45 or centane index min. 42 • Lubricity max. 520 µm • Particle distribution in accordance with table "Particle distribution for fuel", see chapter (→ Page 40) 	Approved if: <ul style="list-style-type: none"> • Density at 15 °C min. 0.820 g/ml • Sulfur content max. 500 mg/kg 	Approved if: <ul style="list-style-type: none"> • Sulfur content max. 500 mg/kg 	
DIN 51603-1:2020-09, heating oil EL low-sulfur <ul style="list-style-type: none"> • Cetane number min. 45 or centane index min. 42 • Lubricity max. 520 µm • Particle distribution in accordance with table "Particle distribution for fuel", see chapter (→ Page 40) 	Approved	Approved	
DIN 51603-6:2017-03, heating oil EL alternative	Not approved	Not approved	

Approved fuels Fuel specifications	Series 4000		
	4000Gx3	4000Gx4	4000Gx5
DIN 51603-1:2020-09, heating oil EL Standard <ul style="list-style-type: none"> • Cetane number min. 45 or centane index min. 42 • Lubricity max. 520 µm • Particle distribution in accordance with table "Particle distribution for fuel", see chapter (→ Page 40) 	Approved	Approved	Not approved
DIN 51603-1:2020-09, heating oil EL low-sulfur <ul style="list-style-type: none"> • Cetane number min. 45 or centane index min. 42 • Lubricity max. 520 µm • Particle distribution in accordance with table "Particle distribution for fuel", see chapter (→ Page 40) 	Approved	Approved	Not approved
DIN 51603-6:2017-03, heating oil EL alternative	Not approved	Not approved	Not approved

4.2.5 Marine distillate fuels according to ISO 8217:2018-10

Commercially available diesel fuels meeting the following specifications are approved for use:

Approved fuel grades Fuel specifications	Series 2000	
	2000Gx5	2000Gx6
DMX <ul style="list-style-type: none"> Water content: 200 mg/kg Total contamination: max. 24 mg/kg Particle distribution in accordance with table "Particle distribution for fuel", see chapter (→ Page 40) 	Not approved	Not approved
DMZ <ul style="list-style-type: none"> Water content: 200 mg/kg Total contamination: max. 24 mg/kg Particle distribution in accordance with table "Particle distribution for fuel", see chapter (→ Page 40) 	Not approved	Not approved
DMA <ul style="list-style-type: none"> Water content: 200 mg/kg Total contamination: max. 24 mg/kg Particle distribution in accordance with table "Particle distribution for fuel", see chapter (→ Page 40) 	Not approved	Not approved
DMB	Not approved	Not approved
Approved fuel grades Fuel specifications	Series 4000	
	4000Gx3	4000Gx4
DMX <ul style="list-style-type: none"> Water content: 200 mg/kg Total contamination: max. 24 mg/kg Particle distribution in accordance with table "Particle distribution for fuel", see chapter (→ Page 40) 	Approved if: <ul style="list-style-type: none"> Viscosity > 4.5 mm²/s: Preheating required 	Approved if: <ul style="list-style-type: none"> Viscosity > 4.5 mm²/s: Preheating required
DMZ <ul style="list-style-type: none"> Water content: 200 mg/kg Total contamination: max. 24 mg/kg Particle distribution in accordance with table "Particle distribution for fuel", see chapter (→ Page 40) 	Approved if: <ul style="list-style-type: none"> Viscosity 1.5 to 4.5 mm²/s Outside the limit range between 1.5 and 4.5 mm²/s: Approval possible in coordination with Rolls-Royce Solutions, for example through restricting the temperature range or through preheating Density 0.820 to 0.860 g/ml Cetane number min. 45 or cetane index min. 42 	Approved if: <ul style="list-style-type: none"> Viscosity > 4.5 mm²/s: Preheating required

Approved fuel grades Fuel specifications	Series 4000	
	4000Gx3	4000Gx4
DMA <ul style="list-style-type: none"> • Water content: 200 mg/kg • Total contamination: max. 24 mg/kg • Particle distribution in accordance with table "Particle distribution for fuel", see chapter (→ Page 40) 	Approved if: <ul style="list-style-type: none"> • Viscosity 1.5 to 4.5 mm²/s • Outside the limit range between 1.5 and 4.5 mm²/s: Approval possible in coordination with Rolls-Royce Solutions, for example through restricting the temperature range or through preheating • Density 0.820 to 0.860 g/ml • Cetane number min. 45 or cetane index min. 42 	<ul style="list-style-type: none"> • Approved if: <ul style="list-style-type: none"> – Viscosity > 4.5 mm²/s: Preheating required
DMB	Not approved	Not approved

Approved fuel grades Fuel specifications	Series 4000 4000Gx5
DMX <ul style="list-style-type: none"> • Water content: 200 mg/kg • Total contamination: max. 24 mg/kg • Particle distribution in accordance with table "Particle distribution for fuel", see chapter (→ Page 40) 	Not approved
DMZ <ul style="list-style-type: none"> • Water content: 200 mg/kg • Total contamination: max. 24 mg/kg • Particle distribution in accordance with table "Particle distribution for fuel", see chapter (→ Page 40) 	Not approved
DMA <ul style="list-style-type: none"> • Water content: 200 mg/kg • Total contamination: max. 24 mg/kg • Particle distribution in accordance with table "Particle distribution for fuel", see chapter (→ Page 40) 	Not approved
DMB	Not approved

4.2.6 Aviation turbine fuels

Commercially available diesel fuels meeting the following specifications are approved for use:

Approved fuel grades Fuel specifications	Series 2000	
	2000Gx5	2000Gx6
F-34 / F-35 • JP-8	Not approved	Not approved
F-44 • JP-5	Not approved	Not approved
F-63 • In accordance with DCSEA 108/A	Not approved	Not approved

Approved fuel grades Fuel specifications	Series 4000	
	4000Gx3	4000Gx4
F-34 / F-35 • JP-8	Not approved	Not approved
F-44 • JP-5	Not approved	Not approved
F-63 • In accordance with DCSEA 108/A	Approved	Approved

Approved fuel grades Fuel specifications	Series 4000
	4000Gx5
F-34 / F-35 • JP-8	Not approved
F-44 • JP-5	Not approved
F-63 • In accordance with DCSEA 108/A	Generally not approved, approval upon request

4.2.7 NATO diesel fuels

Commercially available diesel fuels meeting the following specifications are approved for use:

Diesel fuel NATO Code F-54

Approved fuel grades Fuel specifications	Series 2000	
	2000Gx5	2000Gx6
NATO Code F-54 in accordance with STANAG 7090 Edition 4 <ul style="list-style-type: none"> Approval if fuel corresponds to diesel fuel EN 590:2022-05 Density: Min. 0.820 g/ml Total contamination: max. 24 mg/kg Lubricity: Max. 520 µm Particle distribution in accordance with table "Particle distribution for fuel", see chapter (→ Page 40) 	Approved if: <ul style="list-style-type: none"> Sulfur content max. 500 mg/kg 	Approved if: <ul style="list-style-type: none"> Sulfur content max. 500 mg/kg
Approved fuel grades Fuel specifications	Series 4000	
	4000Gx3	4000Gx4
NATO Code F-54 in accordance with STANAG 7090 Edition 4 <ul style="list-style-type: none"> Approval if fuel corresponds to diesel fuel EN 590:2022-05 Density: Min. 0.820 g/ml Total contamination: max. 24 mg/kg Lubricity: Max. 520 µm Particle distribution in accordance with table "Particle distribution for fuel", see chapter (→ Page 40) 	Approved	Approved
Approved fuel grades Fuel specifications	Series 4000	
	4000Gx5	
NATO Code F-54 in accordance with STANAG 7090 Edition 4 <ul style="list-style-type: none"> Approval if fuel corresponds to diesel fuel EN 590:2022-05 Density: Min. 0.820 g/ml Total contamination: max. 24 mg/kg Lubricity: Max. 520 µm Particle distribution in accordance with table "Particle distribution for fuel", see chapter (→ Page 40) 	Not approved	

Diesel fuel NATO Code F-75

Approved fuel grades Fuel specifications	Series 2000	
	2000Gx5	2000Gx6
NATO-Code F-75 in accordance with TL 9140-0003 <ul style="list-style-type: none"> • Reduced power possible due to min. density of 0.815 g/ml • Particle distribution in accordance with table "Particle distribution for fuel", see chapter (→ Page 40) 	Not approved	Not approved
NATO-Code F-75 in accordance with STANAG 1385 <ul style="list-style-type: none"> • Possible power reduction and increase due to density range of 0.815 to 0.880 g/ml • max. sulfur content 1.0% • Adapt oil and oil change interval • Water content: max. 200 mg/kg • Total contamination: max. 24 mg/kg • Particle distribution in accordance with table "Particle distribution for fuel", see chapter (→ Page 40) 	Not approved	Not approved
Approved fuel grades Fuel specifications	Series 4000	
	4000Gx3	4000Gx4
NATO-Code F-75 in accordance with TL 9140-0003 <ul style="list-style-type: none"> • Reduced power possible due to min. density of 0.815 g/ml • Particle distribution in accordance with table "Particle distribution for fuel", see chapter (→ Page 40) 	Approved	<ul style="list-style-type: none"> • Approved
NATO-Code F-75 in accordance with STANAG 1385 <ul style="list-style-type: none"> • Possible power reduction and increase due to density range of 0.815 to 0.880 g/ml • max. sulfur content 1.0% • Adapt oil and oil change interval • Water content: max. 200 mg/kg • Total contamination: max. 24 mg/kg • Particle distribution in accordance with table "Particle distribution for fuel", see chapter (→ Page 40) 	Approved if: <ul style="list-style-type: none"> • Cetane number min. 45 or cetane index min. 42 	Approved if: <ul style="list-style-type: none"> • Cetane number min. 45 or cetane index min. 42

Approved fuel grades Fuel specifications	Series 4000 4000Gx5
NATO-Code F-75 in accordance with TL 9140-0003 <ul style="list-style-type: none"> • Reduced power possible due to min. density of 0.815 g/ml • Particle distribution in accordance with table "Particle distribution for fuel", see chapter (→ Page 40) 	Not approved
NATO-Code F-75 in accordance with STANAG 1385 <ul style="list-style-type: none"> • Possible power reduction and increase due to density range of 0.815 to 0.880 g/ml • Max. sulfur content 1.0% • Adapt oil and oil change interval • Water content: max. 200 mg/kg • Total contamination: max. 24 mg/kg • Particle distribution in accordance with table "Particle distribution for fuel", see chapter (→ Page 40) 	Not approved

Diesel fuel NATO Code F-76

Approved fuel grades Fuel specifications	Series 2000	
	2000Gx5	2000Gx6
NATO Code F-76 in accordance with STANAG 1385 Edition 6 <ul style="list-style-type: none"> • Water content: max. 200 mg/kg • Density 0.820 to 0.860 g/ml • Total contamination: max. 24 mg/kg • Particle distribution in accordance with table "Particle distribution for fuel", see chapter (→ Page 40) 	Generally not approved, approval upon request	Generally not approved, approval upon request
NATO-Code F-76 in accordance with DEF-STAN 91-4 Issue 8 <ul style="list-style-type: none"> • Water content: max. 200 mg/kg • Density 0.820 to 0.860 g/ml • Total contamination: max. 24 mg/kg • Particle distribution in accordance with table "Particle distribution for fuel", see chapter (→ Page 40) 	Generally not approved, approval upon request	Generally not approved, approval upon request
NATO-Code F-76 in accordance with MIL-DTL-16884N <ul style="list-style-type: none"> • Water content: max. 200 mg/kg • Density 0.820 to 0.860 g/ml • Total contamination: max. 24 mg/kg • Particle distribution in accordance with table "Particle distribution for fuel", see chapter (→ Page 40) 	Generally not approved, approval upon request	Generally not approved, approval upon request

Approved fuel grades Fuel specifications	Series 4000	
	4000Gx3	4000Gx4
NATO Code F-76 in accordance with STANAG 1385 Edition 6 <ul style="list-style-type: none"> • Water content: max. 200 mg/kg • Density 0.820 to 0.860 g/ml • Total contamination: max. 24 mg/kg • Particle distribution in accordance with table "Particle distribution for fuel", see chapter (→ Page 40) 	Approved if: <ul style="list-style-type: none"> • Cetane number min. 45 or cetane index min. 42 	<ul style="list-style-type: none"> • Approved if: <ul style="list-style-type: none"> – Cetane number min. 45 or cetane index min. 42
NATO-Code F-76 in accordance with DEF-STAN 91-4 Issue 8 <ul style="list-style-type: none"> • Water content: max. 200 mg/kg • Density 0.820 to 0.860 g/ml • Total contamination: max. 24 mg/kg • Particle distribution in accordance with table "Particle distribution for fuel", see chapter (→ Page 40) 	Approved	Approved
NATO-Code F-76 in accordance with MIL-DTL-16884N <ul style="list-style-type: none"> • Water content: max. 200 mg/kg • Density 0.820 to 0.860 g/ml • Total contamination: max. 24 mg/kg • Particle distribution in accordance with table "Particle distribution for fuel", see chapter (→ Page 40) 	Approved if: <ul style="list-style-type: none"> • Cetane number min. 45 or cetane index min. 42 	<ul style="list-style-type: none"> • Approved if: <ul style="list-style-type: none"> – Cetane number min. 45 or cetane index min. 42

Approved fuel grades Fuel specifications	Series 4000	
	4000Gx5	
NATO Code F-76 in accordance with STANAG 1385 Edition 6 <ul style="list-style-type: none"> • Water content: max. 200 mg/kg • Density 0.820 to 0.860 g/ml • Total contamination: max. 24 mg/kg • Particle distribution in accordance with table "Particle distribution for fuel", see chapter (→ Page 40) 	Not approved	
NATO-Code F-76 in accordance with DEF-STAN 91-4 Issue 8 <ul style="list-style-type: none"> • Water content: max. 200 mg/kg • Density 0.820 to 0.860 g/ml • Total contamination: max. 24 mg/kg • Particle distribution in accordance with table "Particle distribution for fuel", see chapter (→ Page 40) 	Not approved	
NATO-Code F-76 in accordance with MIL-DTL-16884N <ul style="list-style-type: none"> • Water content: max. 200 mg/kg • Density 0.820 to 0.860 g/ml • Total contamination: max. 24 mg/kg • Particle distribution in accordance with table "Particle distribution for fuel", see chapter (→ Page 40) 	Not approved	

TIN-ID: 0000080028 - 005

4.2.8 Paraffinic diesel fuel in accordance with EN 15940

Standards define paraffinic diesel fuels as being fuels produced by synthesis or hydrogenation processes. They are specified in the EN 15940 standard.

Synthesis

In this case, the term synthesis is used to denote the Fischer-Tropsch reaction. These fuels are therefore also often referred to as Fischer-Tropsch fuels or also XtL (X to Liquid), where “X” stands for the type of initial feedstock. Such fuels are produced by first generating a mixture of carbon monoxide and hydrogen, referred to as synthesis gas, from the initial feedstock. This is then used to create the paraffinic fuel via Fischer-Tropsch synthesis by means of chain growth.

Hydrogenation

Hydrogenation is the chemical reaction of the feedstock with hydrogen. The initial feedstock used are vegetable oils/waste fats and waste materials containing oil which do not compete with foodstuff production. This fuel is marketed as an HVO (Hydrotreated Vegetable Oil).

Designations and description of paraffinic fuels

Depending on the initial feedstock, paraffinic fuels are designated, for example, as follows:

- HVO = Hydrotreated Vegetable oil, initial feedstock: Biomass
- GtL = Gas to liquid, initial feedstock: Natural gas, biogas
- BtL = Biomass to liquid, initial feedstock: Biomass

As a result of the production process, paraffinic fuels consist almost entirely of linear or branched hydrocarbon chains, known as alkanes. They do not contain any sulfur and are almost free of aromatics. Due to their chemical composition, paraffinic fuels have different properties to fossil diesel fuels in terms of higher ignitability and lower density. The result is an overall reduction in untreated emissions.

EN 590 specifies that fatty acid methyl ester (FAME as per EN 14214) can be blended into paraffinic diesel fuel as per EN 15940 by up to 7% by volume.

Paraffinic diesel fuels are specified in ASTM D975 (Grade 1-D and Grade 2-D, S15) in the US, just like fossil diesel fuels. This is possible as this standard does not specify any limit value for density, in contrast to EN 590. These paraffinic diesel fuels can also be used provided that they comply with the fuel values listed in table (→ Table 22). In the US, paraffinic diesel fuels are often referred to as “R99 fuels” or “renewables”

The quality of the fuel is very important for satisfactory engine performance, long engine service life and acceptable exhaust emission levels. Paraffinic fuels must therefore meet the following fuel specifications:

Fuel specifications to be complied with

		Test methods		Limit values
		ASTM		
Composition				The diesel fuel must be free of inorganic acids, visible water, solid foreign matter, and chlorine compounds.
Total contamination (= fuel-insoluble ingredients)	Max.	D6217	EN 12662	24 mg/kg
Density at 15 °C	Min.	D1298	EN ISO 3675	0.765 g/ml ¹⁾
	Max.	D4052	EN ISO 12185	0.860 g/ml
API gravity at 60 °F	Min.	D287		53
	Max.			33

TIM-ID: 0000115325 - 003

		Test methods		Limit values
		ASTM		
Viscosity at 40 °C	Min.	D445	EN ISO 3104	1.5 mm ² /s
	Max.			4.5 mm ² /s
Flashpoint (closed crucible)	Greater	D93	DIN EN ISO 27 19	55 °C (60 °C for SOLAS) ²⁾
Boiling curve:		D86	EN 17306	
– Initial boiling point				160 to 220 °C
– Volume share at 250 °C	Max.			65% by volume
– Volume share at 350 °C	Min.			85% by volume
– Residue and loss	Max.			3% by volume
Fatty acid methyl ester content (FAME) (“Biodiesel”)	Max.		EN 14078 Internal mtu procedure	7.0% by volume
Water content: (absolute, no free water)	Max.	D6304	EN ISO 12937	200 mg/kg
Carbon residue from 10% distillation residue	Max.	D189	EN ISO 10370	0.30% by weight
Oxide ash: ³⁾ – Engines without exhaust gas aftertreatment and without exhaust gas recirculation	Max.	D482	EN ISO 6245	0.01% by weight (100 mg/kg)
Sulfur content	Max.	D5453 D2622	EN ISO 20848 EN ISO 20884	0.0015% by weight (15 mg/kg) ³⁾
Cetane number	Min. Max.	D613	EN ISO 5165 EN ISO 15195	45 80 ⁴⁾
Cetane index	Min.			D976
Copper corrosion 3 hrs. at 50 °C	Max. degree of corrosion	D130	EN ISO 2160	1a
Oxidation stability (Rancimat) ⁵⁾	Min.		EN 15751	20 hours
Oxidation stability ⁶⁾	Max.	D2274	EN ISO 12205	25 g/m ³
Lubricity at 60 °C (HFRR value)	Max.	D6079	EN ISO 12156-1	400 µm
Neutralization number	Max.	D974		0.2 mg KOH/g

Table 22: Fuel specifications to be complied with

- ¹⁾ = May result in reduced power on engines featuring unit-pump injection systems (PLD).
- ²⁾ = A min. flashpoint of 60 °C applies to marine applications (SOLAS = Safety of life at sea).
- ³⁾ = Note: 1% by weight = 10,000 mg/kg = 10,000 ppm.
- ⁴⁾ = Higher cetane number possible upon request from Rolls-Royce Solutions GmbH.
- ⁵⁾ = Relevant for diesel fuel with a FAME content of ≥ 2% by volume
- ⁶⁾ = Relevant for diesel fuel with a FAME content of < 2% by volume

Compliance with the requirements stipulated in the tables “Cylinder head TBO” and “Series-related injection/and exhaust gas aftertreatment systems (EGAT)” (→ Page 40) is mandatory with regard to winter operation and purity requirements for diesel fuel.

Paraffinic diesel fuels as per EN 15940 or ASTM D975 (Grade 1-D and Grade 2-D, S15) have been approved for the following series provided that they comply with the characteristic values specified in the table (→ Table 23):

Engine		Safety ¹⁾	Not certified	Emission level			Comments
Series	Application			EPA	EU	IMO	
4000	Gx3	X	X	T2			
4000	Gx4	X	X	T2			

Table 23: Approvals for paraffinic diesel fuels as per EN 15940 or ASTM D975 (Grade 1-D and Grade 2-D, S15)

¹⁾ Product safety in terms of the risk to life and limb is assured when these fuels are used in the engine.

Important
Further project-specific approvals are possible upon request from Rolls-Royce Solutions GmbH.

Effects of paraffinic diesel fuels on elastomer components

Paraffinic diesel fuels are compatible with conventional elastomer materials such as FKM (fluorocautchouc) and NBR (nitrile butadien rubber). Being free of aromatics, they cause less swelling than fossil diesel fuels containing aromatics. For this reason, the possibility of leakages when transitioning from fossil diesel fuels to paraffinic diesel fuels cannot be completely excluded.

Procedure for transitioning from fossil to paraffinic diesel fuels

Our experience shows that transitioning can be done with no problems for scopes of supply of Rolls-Royce Solutions. Despite this, to prevent residual risks, Rolls-Royce Solutions recommends routine inspection of the gaskets to verify leak-tightness in the first four weeks after transitioning to paraffinic diesel fuel.

Notes on operation with water separators

Paraffinic diesel fuel has a greater tendency to discharge free water into water separators compared with conventional fossil diesel fuel. Slightly higher water discharge in water separators in comparison with fossil diesel fuel is normal.

Blending paraffinic diesel fuels with conventional fossil diesel fuels

Paraffinic diesel fuels are known as “drop-in” fuels.

This means that the end customer can mix paraffinic diesel fuel with conventional fossil fuels in any ratio without having to make any adjustments to the engine or fuel system.

This means that the end customer can fill up with both paraffinic and conventional fossil diesel fuel according to the tables “Fuel values to be complied with” (→ Page 40) without having to empty/clean the tank beforehand.

“Premium diesel fuels” which comply with EN 590 and also reduce CO₂ emissions by around 20% are also available on the market. Paraffinic diesel fuel in accordance with EN 15940 is already added to these fuels at the manufacturer’s facility. The amount of paraffinic diesel fuel added, however, is only high enough to ensure observance of the required minimum density limit value specified in EN 590.

4.2.9 Engine operation on diesel fuel with a biodiesel content of up to 30%

Important

Project-specific approval from Rolls-Royce Solutions GmbH is possible upon request.

The term biodiesel is used for what the standards refer to as “FAME” (Fatty Acid Methyl Ester) in this case.

More information about diesel fuel containing up to 30% FAME is provided below and in the Customer Information entitled “Diesel fuel containing up to 30% FAME” (publication number A060632/..).

Use of diesel fuel containing up to 30% FAME

Biodiesel mixtures consist of fuels which are obtained from biogenic raw materials and mixed with conventional diesel fuel. For instance, B20 denotes a mixture comprising 20% biodiesel and 80% fuel based on crude oil/mineral oil. mtu engines were not specially designed to be operated with biodiesel mixtures. For this reason, the use of biodiesel mixtures may have negative effects in terms of engine power, service and maintenance requirements, emissions and useful life.

Operators of mtu engines therefore need to be clear about the effects that biodiesel may have on their engines, and must take all of the necessary measures to ensure the reliability and safety of their engines. This chapter provides Rolls-Royce Solutions customers with important information on the use of biodiesel mixtures in mtu engines and explains the potential impact these fuels may have on the Rolls-Royce Solutions warranty. Please read this information carefully before using biodiesel mixtures in mtu engines.

1. Regarding the use of approved biodiesel mixtures

At present, only biodiesel mixtures with up to 7% biodiesel (in accordance with EN 590) or 5% biodiesel (in accordance with ASTM D 975) are approved for use in the Fluids and Lubricants Specifications.

Although not currently approved in the Fluids and Lubricants Specifications, biodiesel mixtures containing up to 30% biodiesel (B30) may be used in the engines listed in section 6 below,

- PROVIDING THAT the following requirements are met:
 - The biodiesel mixtures are specified according to the following standards:
 1. 3675.K/24/DJM (standard for diesel fuel with 10% biodiesel content, i.e. B10, in Indonesia)
 2. 28.K/10/DJM.T (standard for diesel fuel with 20% biodiesel content, i.e. B20, in Indonesia)
 3. 0234.K/10/DJM.S/2019 (standard for diesel fuel with 30% biodiesel content, i.e. B30, in Indonesia)
 4. EN 16734 (European standard for diesel fuel with 10% biodiesel content, i.e. B10)
 5. EN 16709 (European standard for diesel fuel with 20% and 30% biodiesel content, i.e. B20 and B30)
 6. ASTM D7467 (US standard for diesel fuel with 6% to 20% biodiesel content, i.e. B6 - B20)
 7. The biodiesel used for mixing complies with the standards EN 14214, ASTM D 6751 or SNI 71825
 8. The distilled diesel fuel used for mixing is approved in the latest version of the Fluids and Lubricants Specifications.
 9. The operator complies with the operating requirements given in section 2 and the additional maintenance recommendations from section 5.

Important

The provisions with regard to requirements placed on fuel may differ depending on legislation and application of the engine. The operator is responsible for ensuring that only fuels which comply with the applicable provisions are used in the engines.

2. Operating requirements for the use of diesel fuels with a biodiesel content of up to 30%

The following operating requirements must be met when biodiesel mixtures are used in mtu engines:

- a For engines used in standby gensets, an additive must be used to improve the oxidation stability of the biodiesel.
- b All engines used in fire-fighting pumps, fire-extinguishing equipment or police equipment must be thoroughly flushed with pure, biodiesel-free, high-quality distilled diesel fuel which complies with the Fluids and Lubricants Specifications each time they are operated with a biodiesel mixture. Furthermore, an additive must be used in these engines to improve the oxidation stability of the biodiesel.
- c All engines which are only used seasonally or which are not operated for extended periods between uses must be thoroughly flushed with pure, biodiesel-free, high-quality distilled diesel fuel which complies with the Fluids and Lubricants Specifications before they are decommissioned.
- d Biodiesel mixtures can not be used in engines equipped with an exhaust gas aftertreatment system (e.g. catalytic converters, particle filters (DPF) and/or systems for reducing NOx emissions, e.g. SCR systems).

3. Impact on the Rolls-Royce Solutions warranty

The manufacturer shall not be responsible for failures which can be attributed to the use of fuels not approved in these Fluids and Lubricants Specifications and such failures shall therefore not be covered by the Rolls-Royce Solutions warranty. Rolls-Royce Solutions shall reject all warranty claims connected to the use of biodiesel mixtures with a biodiesel content of more than 7% (in accordance with EN 590) or 5% (in accordance with ASTM D 975) if the operator is unable to prove that the operating requirements and recommendations contained in this letter were met and strictly followed. Regardless of this, Rolls-Royce Solutions shall on no account be liable for providing compensation for costs arising from the effects described below in section 4.

Important

All properties guaranteed by Rolls-Royce Solutions in terms of assured characteristics with regard to engine power and/or operational availability only apply to the cases in which fuels approved by Rolls-Royce Solutions are used and the engine demonstrates no defects or damage arising from operation with fuels not approved in these Fluids and Lubricants Specifications.

4. Effects of biodiesel on engines/exclusion of liability

The biodiesel contained in biodiesel mixtures is a natural product and therefore undergoes natural aging processes. These may have a negative effect on the engines in which the biodiesel mixtures are used. The effects that biodiesel may have on engines are explained below.

Important: THESE EFFECTS ARE NOT FAULTS CAUSED BY THE ENGINE MANUFACTURER. THEY ARE THEREFORE EXCLUDED FROM THE Rolls-Royce Solutions WARRANTY. ROLLS-ROYCE SOLUTIONS SHALL NOT ASSUME ANY LIABILITY FOR COSTS ARISING FROM THE EFFECTS DESCRIBED BELOW.

- The formation of deposits may cause components to become “sticky”, which potentially restricts their movement. On engines with long downtimes, this can result in a situation where the engine can no longer be started. This is why additives for improving the oxidation stability of the biodiesel must be employed when biodiesel mixtures are used in standby gensets. ROLLS-ROYCE SOLUTIONS SHALL ACCEPT NO LIABILITY IN THE EVENT THAT THE ENGINE IN AN STANDBY GENSET CAN NOT BE STARTED AS A RESULT OF THE FORMATION OF DEPOSITS.
- The formation of deposits may have an adverse effect on the interaction of components inside the unit. This results in an increased risk of components failing, and even the breakdown of entire cylinders. The high operating temperatures in the surroundings encourage the formation of mineral deposits, other deposits and encrustations which may render the valve unable to correctly regulate the fuel supply. This means that it is no longer possible for the quantity of fuel required at full load to be injected into the engine, thereby reducing the maximum engine power.
- The viscosity properties of biodiesel are less favorable at low temperatures. The use of biodiesel at low temperatures may therefore cause the fuel filter to become clogged.
- On all engines, lubricating the piston skirts with oil leads to a small amount of fuel entering the engine oil. This is generally of little importance with conventional diesel fuels in accordance with these Fluids and Lubricants Specifications since the fuel evaporates quickly upon reaching the operating temperature. On the other hand, biodiesel evaporates much less effectively, with the result that more biodiesel accumulates in the oil. Aging of the biodiesel can therefore cause residues to form, filters to become clogged and ultimately cause the engine to come to a stop, resulting in significantly shorter oil change intervals.
- Compared to conventional diesel fuels according to these Fluids and Lubricants Specifications, biodiesel has a lower energy density. Operating the engine with B20 results in a power reduction of approximately 2% and an increase in fuel consumption of around 3%.
- Biodiesel contains chemical components which can interact with the sensors in the exhaust gas recirculation system in such a way that incorrect data is reported to the engine control system. This can have consequences such as engine operation being adapted to the wrong values and emissions therefore no longer complying with the applicable provisions. This is why biodiesel must not be used in engines which feature exhaust gas recirculation (EGR) and/or exhaust gas aftertreatment systems.
- Compared to conventional diesel fuels according to these Fluids and Lubricants Specifications, biodiesel has a higher water solubility, meaning that a higher proportion of water should be expected depending on the fuel temperature. This can lead to increased corrosion and faster microbe growth in the fuel system. Due to the higher proportion of water in biodiesel, reduced water separator performance must be expected.
- Biodiesel is a solvent. After switching over to a biodiesel mixture, impurities and certain deposits may become loose in the tank and lines, causing the fuel filter to be subjected to an increased accumulation of these. Biodiesel mixtures may also strip paint when they come into contact with painted surfaces.
- On engines with exhaust gas aftertreatment systems, the functioning of the catalytic converter may be impaired as biodiesel mixtures can contain a higher proportion of trace elements (e.g. calcium, magnesium, sodium, potassium and phosphorus) than conventional diesel fuels according to these Fluids and Lubricants Specifications. This means that the legally prescribed emissions limits are not complied with and the operating license becomes invalid. Furthermore, legally prescribed technologies for checking emissions on these engines (e.g. NOx monitoring diagnostics) lead to a significant decrease in engine power. The above-mentioned trace elements may also result in excess ash formation and accumulations in the soot filters and catalytic converters. Excess ash formation results in a constantly rising exhaust back pressure and can therefore cause a slow reduction in engine power.

The above-mentioned points do not constitute a complete risk assessment. Rolls-Royce Solutions is unable to assess all biodiesel variants and their long-term effects on mtu products.

5. Additional maintenance recommendations

The following requirements must be met to ensure the quality and operational availability of your engine:

- Select the highest possible content of distilled fuel. Only use fuels approved in these Fluids and Lubricants Specifications.
- After switching over to a biodiesel mixture, replace the fuel filters after 50 operating hours at the latest (in order to remove the impurities which become loose from the tank and lines).
- The fuel filters and fuel prefilters must be renewed every 250 operating hours.
- Install a fuel preheating system if the engine is operated at temperatures below 0 °C (32 °F). This can reduce the negative effect on the fuel supply.
- Follow the recommendations below with regard to engine oil and maintenance:
 - If biodiesel mixtures are used, the change intervals for engine oil and filters must be halved in comparison to the intervals stated in these Fluids and Lubricants Specifications.
 - The component TBO of the LP fuel pump, the O-rings in the LP fuel system as well as the valves in the fuel filter head is shortened to TBO/3.
 - In addition to changing the oil and filters on time, the engine oil and filters must be analyzed regularly in order to ensure that the oil quality is correct. Interval: Every 100 operating hours or every three months, depending on which comes first. A decision must be made to either further reduce or extend the change intervals on the basis of the results.
 - The oil and oil filter must be replaced before biodiesel is used.
 - High-quality engine oil must be used. Operating the engine without high-quality category 2 oil leads to a deterioration in oil quality. These Fluids and Lubricants Specifications contain a list of approved oil types.
- Use a suitable tank and line system:
 - Do not use any components which contain zinc, copper or NBR seals.
 - Ensure that the system can be filled up to the fill line.
 - Minimize the entry of atmospheric oxygen through the tank vent in the event of temperature fluctuations, etc. (e.g. by installing a pressure relief valve and filter; contact your tank supplier to do this).
 - It is recommended to use a tank vent with humidity separator.
- For systems without a water separator: Retrofit a water separator to reduce the risk of microbe growth and corrosion in the fuel system.
- Regular maintenance of the water separator is mandatory. Separated water must be drained off daily, depending on the water quantity.
- Avoid longer engine downtimes and temporary shutdowns (>1 week for B20 or >3 days for B30). If downtimes can not be avoided, a suitable additive must be used to improve oxidation stability. Rolls-Royce Solutions can recommend a suitable additive on request.
- For B30:
 - The engine must be started once within 24 hours and run at idle for 5 minutes.
- For engines used seasonally, we strongly recommend flushing the fuel system, including the fuel tank, with pure, biodiesel-free, high-quality distilled diesel fuel in accordance with these Fluids and Lubricants Specifications before the engine is shut down for a relatively long period (>1 week for B20 or >3 days for B30). The reason for this is the lack of empirical data for the country-specific fuel specification.
- Prevent biodiesel from coming into contact with painted surfaces to avoid damaging and stripping the paint.
- Furthermore, always ensure that the most recent version of the Fluids and Lubricants Specifications is available and its contents are observed.

More extensive preventative measures are additionally required for some applications. Our product support department is available to answer any questions you may have on this topic.

6. Affected engines

This customer information applies to the following engine series:

Series	Comments
S1600Gx0	All years of manufacture
S2000Gx2 S2000Gx3 S2000Gx4 S2000Gx5 S2000Gx6	All years of manufacture With metal low-pressure fuel lines All years of manufacture All years of manufacture All years of manufacture
S4000Cx0 S4000Cx1 S4000Gx1 S4000Gx2 S4000Gx3 S4000Gx4 S4000Mx0 S4000Mx1 S4000Mx3 S4000Px1 S4000Px3 S4000Rx3	All years of manufacture All years of manufacture With metal low-pressure fuel lines All years of manufacture All years of manufacture All years of manufacture All years of manufacture All years of manufacture All years of manufacture All years of manufacture All years of manufacture All years of manufacture From year of manufacture 2020 onward / only with rest-of-world fuel filter configuration
S1163Mx4	All years of manufacture
S8000Mx1	All years of manufacture

Table 24: For the use of fuels containing up to 20% biodiesel (B20)

Series	Comments
S4000Gx3 S4000Gx4 S4000Mx0 S4000Mx1 S4000Mx3	All years of manufacture All years of manufacture All years of manufacture All years of manufacture All years of manufacture
S1163Mx4	All years of manufacture
S8000Mx1	All years of manufacture

Table 25: For the use of fuels containing more than 20% biodiesel (B20) up to a maximum biodiesel content of 30% (B30)

Should you have any questions about this customer information, please contact your local Rolls-Royce Solutions representative.

4.3 Engine operation on pure biodiesel (B100) and vegetable oil

The standardized generic term “FAME”, (Fatty Acid Methyl Ester) is used here to designate biodiesel fuels.

General notes

- We can make no comment with regard to the level of FAME resistance of the fuel system, which is not part of our scope of supply.
- FAME is an extremely effective solvent. Any contact with paint, for example, must therefore be avoided.
- The characteristic smell of FAME exhaust, especially during long periods of idling, may be perceived as unpleasant. The nuisance caused by smell can be reduced by an oxidation catalyst which may be installed by the vehicle / equipment manufacturers at their own risk.

Important

Our company accepts no responsibility for and provides no warranty in respect of any fault or damage connected in any way with the use of FAME of a lower quality or resulting from noncompliance with our specifications on operation using FAME. All resultant irregularities and consequential damage lie outside our responsibility.

The following engines are approved/not approved for operation with 100% FAME in compliance with DIN EN 14214:2019-05.

Approved/non-approved engines for operation with 100% FAME

Series	Release	Conversion necessary
SUN		Not approved
700		Not approved
750		Not approved
OM 457 LA	From series introduction	No
460	From series introduction	No
900	From series introduction	No
500	From series introduction	No
S40		Not approved
S50		Not approved
S60		Not approved
183		Not approved
2000		Not approved
396		Not approved
4000		Not approved
538		Not approved
595		Not approved
956		Not approved
1163		Not approved
8000		Not approved

Table 26:

Important

The use of diesel fuel with a FAME content of max. 7% in compliance with EN 590:2022-05 is unproblematic. Such fuel may also be used in engines which have not been approved for operation with FAME, without affecting oil drain intervals.

Fuel

- The FAME must comply with DIN EN 14214:2019-05. Operation with fuels of lower quality can lead to damage and malfunctions.
- Either FAME or diesel fuel may be used. The various mixtures of FAME and normal diesel fuel, which may occur in the fuel tank as a result, present no problems.

Engine oil and servicing

- For operation using 100% FAME, engine oils are to be preferred which comply with MB Fluids and Lubricants Specifications, Sheet 228.5 or Oil Category 3 in accordance with these Fluids and Lubricants Specifications. Engine oils in accordance with Sheet 228.3 or Oil Category 2 as per these Fluids and Lubricants Specifications may also be used provided that oil drain intervals are reduced.
- A certain amount of fuel always finds its way into the engine oil via the pistons and cylinders. Its high boiling point means that FAME does not evaporate but remains in the engine oil in its entirety. Under certain conditions chemical reactions may take place between FAME and the engine oil. This can lead to engine damage.
- In case of straight FAME operation, therefore, the change intervals for engine oil and oil filters must be reduced.
- For Series 457, 460, 900 and 500 engines, special equipment is available which facilitates an increase in the engine oil change intervals for operation with 100% FAME (→ Table 27). This involves fitting the engines with special equipment Code MK21 (special unit pump) and Code MK04 (fuel prefilter with heated water separator).

Effects on the engine oil change interval with operation with 100% FAME

Engine version	Engine oil change interval
Engines not fitted with special equipment for operation with FAME	Reduction of engine oil change interval to 30% of the standard interval required for operation with fossil diesel fuels
Engines fitted with special equipment Code MK21 and Code MK04	Reduction of engine oil change interval to 50% of the standard interval required for operation with fossil diesel fuels

Table 27:

Important
The relevant engine oil change intervals must be complied with without fail! Exceeding the engine oil change intervals can cause engine damage!

- Operation with 100% FAME requires shortened fuel filter change intervals. A new fuel filter must be fitted each time the engine oil is changed.
- FAME has a high cleaning effect, which results in a risk of clogging by loosened deposits. If a switch has been made to FAME, a fuel filter and engine oil change should therefore be carried out after approx. 25 operating hours.
- Over longer periods, fuel filter service life may be reduced as a result of old residues being carried into the filter from the fuel system. A special, approved fuel prefilter can be installed as an improvement. This fuel prefilter with heated water separator is already installed on engines fitted with special equipment Code MK04.

Engine power and engine standstill

- Due to its calorific value, operation with 100% FAME involves a reduction of approx. 8% to 10% in engine power. This leads to a corresponding increase in fuel consumption as compared to operation with diesel fuel. Engine power corrections are not permissible.
- Prior to any extended period out of operation, the fuel system must be flushed out in order to prevent congestion. To do this, the engine must be flushed for at least 30 minutes with pure, biodiesel-free, high-grade distilled diesel fuel in accordance with these Fluids and Lubricants Specifications.

Vegetable oils as an alternative to diesel fuel

Important

The use of pure vegetable oils as an alternative to diesel fuel or FAME is strictly prohibited due to negative experience (engine damage caused by coking, deposits in the combustion chambers and oil sludge)!

4.4 Diesel fuels for engines with exhaust gas aftertreatment (EGAT)

Engines with exhaust gas aftertreatment place special demands on the fuels used to guarantee the operational reliability and service life of the exhaust system and the engine.

Depending on the technology used for exhaust gas aftertreatment, the following fuels can be used:

Exhaust gas technology	Technical approval for					
	EN 590:2022-05	ASTM D975-19 Grade 1-D	ASTM D975-19 Grade 2-D	DMX in accordance with DIN ISO 8217:2018-10	DMA in accordance with DIN ISO 8217:2018-10	Heating oil EL low-sulfur in accordance with DIN 51603: 2020-09
Restrictions:						
Diesel oxidation catalyst DOC (without particulate filter)	No limitation	S15	S15	Not approved	Not approved	Not approved
Particle oxidation catalyst (POC)	Ash <10 mg/kg	S15 Ash <10 mg/kg	S15 Ash <10 mg/kg	Not approved	Not approved	Not approved
SCR system with vanadium catalysts (no particulate filter)	Series 4000-M05 EPA T4 → no approval	S15 S<500 mg/kg with individual case approval Series 4000-M05 EPA T4 → no approval Series 4000-M03/M05 IMO III → S <1000 mg/kg	S15 S<500 mg/kg with individual case approval Series 4000-M05 EPA T4 → no approval Series 4000-M03/M05 IMO III → S <1000 mg/kg	Individual case approval Series 4000-M05 EPA T4 → no approval Series 4000-M03/M05 IMO III → S <1000 mg/kg		Series 4000-M05 EPA T4 → no approval Series 4000-M03/M05 IMO III → S <1000 mg/kg
SCR system with zeolith catalysts (no particulate filter)	No limitation	S15 Series 4000-M03 IMO III → S <1000 mg/kg	S15 Series 4000-M03 IMO III → S <1000 mg/kg	Not approved Series 4000-M05 EPA T4 → no approval Series 4000-M03 IMO III → S <1000 mg/kg	Not approved Series 4000-M05 EPA T4 → no approval Series 4000-M03 IMO III → S <1000 mg/kg	Not approved Series 4000-M05 EPA T4 → no approval Series 4000-M03 IMO III → S <1000 mg/kg
Diesel particulate filter (DPF)	Ash <10 mg/kg	S15 Ash <10 mg/kg	S15 Ash <10 mg/kg	Individual case approval		Not approved
Combination system SCR+ particulate filter	Ash <10 mg/kg	S15 Ash <10 mg/kg	S15 Ash <10 mg/kg	Individual case approval		Not approved

Table 28: Diesel fuels for engines with exhaust gas aftertreatment

If the specifications in the tables are not observed, the specified TBO cannot be guaranteed.

Warranty claim cases that result from the use of an impermissible fuel quality shall be rejected.

If a fuel is present that does not comply with the specifications, in certain circumstances Rolls-Royce Solutions can assist in the selection of appropriate improvement measures.

Any possible restrictions related to engine requirements must also be observed.

Important

Use of diesel fuel with a percentage of biodiesel (FAME, fatty acid methyl ester) of max. 7% in accordance with EN 590:2022-05 is unproblematic. The use of fuels with an increased percentage of biodiesel is not permitted for plants with exhaust gas aftertreatment because trace elements they may contain can act as catalyst poisons and lead to filter obstructions.

Important

Commercially available diesel fuels normally contain considerably less ash-forming agents than those certified by the relevant standards (typical ash content max. 0.001% = 10 mg/kg). The particulate filters are designed for these low loads accordingly because the exhaust system would otherwise be completely overdimensioned. The maximum ash content in fuel specified by Rolls-Royce Solutions has been defined to ensure that the particulate filter reaches the assured service life without the back pressure of the filter becoming too high for the engine.

Important

The use of fuel additives for minimizing wear is not permitted on plants with exhaust gas aftertreatment.

Use of fuel additives for lowering soot regeneration temperature on plants with particulate filters

Fuel additives for lowering the soot regeneration temperature (FBC, fuel borne catalyst) are generally not approved. The exhaust gas aftertreatment systems from Rolls-Royce Solutions are designed such that soot regeneration takes place without additives.

4.5 Heating oil EL

Heating oil differs from diesel fuel mainly because of the following non-specified characteristics:

- Cetane number
- Sulfur content
- Oxidation stability
- Corrosion effect on copper
- Lubricity
- Low temperature behavior

If the heating requirements comply with the specifications of the diesel fuel EN 590:2022-05 (summer and winter quality), there are no technical reasons why it can not be used in the diesel engine

4.6 Supplementary fuel additives

Supplementary fuel additives

The engines are designed such that satisfactory operation with normal, commercially available diesel fuels is ensured. Many of these fuels already contain performance-enhancing additives.

The additives are added by the supplier as the party responsible for product quality.

The anti-wear additives (→ Page 75), biocides (→ Page 75) and cleaning additives are exceptions.

Important

Attention is drawn to the fact that the use of diesel fuels or additives other than those stipulated in these Fluids and Lubricants Specifications is always the responsibility of the operator. Prior to using a fuel additive approved by Rolls-Royce Solutions GmbH, the operating company must additionally obtain approval for the use of this additive from the fuel manufacturer to exclude the possibility of any incompatibilities of the additive with the fuel or additives already contained in the fuel from the time of production. Additives must not contain inorganic substances because they can cause damage to the engine and the exhaust gas aftertreatment system.

Diesel fuels with sulfur content < 500 mg/kg

Excessive valve-seat wear occurs on engine series featuring cylinder heads without valve-seat inserts (both inlet and exhaust valves) when low-sulfur fuel grades are used (sulfur content < 500 mg/kg). This applies to the following engine series:

Series	Use of additives
331 up to year of manufacture 1969	Yes*
362	Yes*
396 up to year of manufacture 1975	Yes*
493	Yes*
538	Yes
595	Yes
652	Yes*
956	Yes
1163 up to model type 01-03	Yes*

Table 29:

* = if the cylinder head features valve seat inserts, it is not necessary to use an anti-wear additive in the fuel.

If anti-wear additives are mixed in, this wear can be reduced. The approved supplementary additives must be mixed with the fuel in the predefined concentration. The additive must be filled before every refueling.

Approved anti-wear additives

Manufacturer	Brand name	Concentration for use
The Lubrizol Corporation 29400 Lakeland Boulevard Wickliffe, Ohio 44092 USA Tel. 01 440-943-4200	ADX 766 M	250 to 350 mg/kg
Tunap Industrie GmbH Bürgermeister-Seidl-Str. 2 82515 Wolfratshausen Tel. +49 (0) 8171 1600-0 Fax. +49 (0) 8171 1600-91	Tunadd PS	250 to 350 mg/kg

Table 30:

Important
The use of anti-wear additives is not permitted on engines/plants with exhaust gas aftertreatment!

Microorganisms in fuel

Bacterial attack and sludge formation can occur in the fuel under unfavorable conditions. In such cases, the fuel must be treated with biocides in accordance with the manufacturer's specifications. Overconcentration must always be avoided.

The biocides approved by Rolls-Royce Solutions are listed in table (→ Page 75).

Approved biocides

Biocides should have a pure hydrocarbon structure, i.e. should only consist of the following components:

- Carbon
- Hydrogen
- Oxygen
- Nitrogen

They must not contain inorganic substances because they can cause damage to the engine and the exhaust gas aftertreatment system. The use of halogenated biocides is prohibited due to their effects on the engine system and the environment.

Biocides that contain neither inorganic nor halogenated substances may be used for engine systems with exhaust gas aftertreatment.

Approval for biocides that meet the above requirements is possible upon request.

Manufacturer	Brand name	Concentration for use
ISP Biochema Schwaben GmbH Ashland Specialty Ingredients Luitpoldstrasse 32 87700 Memmingen Tel. +49 (0)8331 9580 0 Fax. +49 (0)8331 9580 51	Bakzid	100 ml / 100 l
Maintenance Technologies Paddy's Pad 1056 CC t/a Maintenance Technologies Tel. +27 21 786 4980 Cell +27 82 598 6830	Dieselcure Fuel Decontaminant	1:1200 (833 mg/kg)

Manufacturer	Brand name	Concentration for use
Adolf Würth GmbH & Co. KG Reinhold Würth-Straße 12-17 74653 Künzelsau Tel. +49 (0)7940 152248	Dieselsure Fuel Decontaminant	1:1200 (833 mg/kg)
Vink Chemicals GmbH & Co.KG Eichenhöhe 29 21255 Kakenstorf Tel. +49 (0)4186 887970 email: info@vink-chemicals.com	grotamar 71 grotamar 82 StabiCor 71	0.5 l / ton 1.0 l / 1000 l 0.5 l / ton
DOW® https://www.dow.com/en-us/about-dow/locations	Kathon™ FP 1.5 Biocide	100 - 200 mg/kg
Supafuel Marketing CC PO Box 1167 Allens Nek 1737 Johannesburg South Africa Tel. +27 83 6010 846 Fax. +27 86 6357 577	Dieselfix / Supafuel	1:1200 (833 mg/kg)
Wilhelmsen Ships Service AS Willem Barentszstraat 50 3165 AB Rotterdam-Albrtands- waard Tel. +31 10 487 7777 Fax. +31 10 487 7888 Netherlands	DieselPower Biocontrol (previously Dieselpower MAR71)	333 ml/ton

Table 31:

Cleaning additives

Under very unfavorable conditions, e.g. aging of fuels, deposits may occur in the injectors. These deposits can be removed with cleaning additives. The additive approved at Rolls Royce Solutions GmbH is listed in table (→ Table 32).

Manufacturer	Brand/Product name	Concentration for use	Notes	Approval for
The Lubrizol Corporation 29400 Lakeland Boulevard Wickliffe, Ohio 44092 USA Tel. +1 440-943-4200	Powerzol 9049	One-time use for injector cleaning in case of deposit formation (push cleaning): 0.3% by volume Continuous use for prevention of coating and deposits: 0.02 to 0.1% by volume	Observe the safety data sheet of the manufacturer and introduce appropriate protective measures! The service life of the fuel filters can be reduced through the use of an additive.	4000Gx3/Gx4 and Gx5 (all application groups, FCO and all emission optimizations)

Table 32:

Flow improvers

Flow improvers can not prevent paraffin precipitation but they do influence the size of the crystals and thus allow the diesel fuel to pass through the filter.

The effectiveness of the flow improvers is not guaranteed for every fuel.

Certainty is only assured after laboratory testing of the filtering capability.

Required quantities and mixing procedures must be carried out according to the manufacturer's instructions.

4.7 Unsuitable materials in the diesel fuel circuit

Components made of copper and zinc materials

Even small amounts of zinc, lead and copper may leave deposits in diesel fuel injection systems, particularly in modern, state-of-the-art injection systems. For this reason, levels of zinc, lead or copper in tanks, fuel lines and filter elements shall not exceed the manufacturer's validated specifications.

Avoid using materials containing these metals as this may initiate catalytic reactions in the fuel leading to undesirable deposits in the injection system.

Requirements

Based on current knowledge, the following materials and coatings must not be used in a diesel fuel circuit because negative mutual reactions can occur even with approved coolant additives.

Metallic materials

- Zinc, also as surface protection
- Zinc-based alloys
- Copper
- Copper-based alloys with the exception of CuNi10 and CuNi30 (e.g. seawater cooler)
- Tin, also as surface protection
- Magnesium-based alloys

Non-metallic materials

- Elastomers: Nitrile butadiene rubber, natural rubber, chloroprene rubber, butyl rubber, EPDM
- Silicone elastomer
- Fluorosilicone elastomer
- Polyurethane
- Polyvinyl

Information:

Consult the relevant Rolls-Royce Solutions specialist department in case of doubt about the use of materials on the engine / externally mounted components in fuel circuits.

4.8 mtu Advanced Fluid Management System for fuels – Test package for North America

A sophisticated system for diagnostics and preventive maintenance is available in North America. This system allows the following:

For full information on the mtu Advanced Fluid Management System available in North America, please contact an authorized Rolls-Royce Solutions service partner.

The following test packages from mtu Advanced Fluid Management System can be ordered from authorized Rolls-Royce Solutions service partners in North America:

- F-PDFM1
Basic test – For checking the degree of contamination of the diesel fuel.
The test determines existing metallic elements and examines the proportion of water and contamination with bacteria and particles.
- F-PDFM2
Extended test – Includes the basic test plus an examination for determination of the degree of contamination, any possible filter contamination and ignition behavior of the engine.
- F-PDFM3
Extended Test Plus – Includes the extended text plus a lubricity analysis.
Maintenance of the correct lubricity has a positive effect on the service life of the components of the engine fuel system.

The following fuel parameters can be determined:

Fuel parameter	F-PDFM1	F-PDFM2	F-PDFM3
24 elementary metals	✓	✓	✓
Viscosity at 40 °C	–	✓	✓
Percent sulfur	–	✓	✓
Water and sediment	✓	✓	✓
Pour point	✓	✓	✓
Thermal stability	✓	✓	✓
Bacteria, fungi and mildew	✓	✓	✓
Flashpoint according to Pensky-Marten	–	✓	✓
Calculated centane index	–	✓	✓
Distillation	–	✓	✓
Cloud point	–	✓	✓
Percentage of water according to Karl Fischer	✓	✓	✓
Particle content	✓	✓	✓
Density according to API	–	✓	✓
Lubricity	–	–	✓

The mtu Advanced Fluid Management System with trend analysis provides information for maximizing system reliability. The following guidelines must be followed to obtain the best results.

Samples must be taken:

- While the engine is operating under normal conditions or immediately after stopping the engine while the engine is still at operating temperature
- Every 250 hours at the same point

Note: The software offered by Rolls-Royce Solutions for online reporting with trend analyses shows the procedure for optimizing evaluation of the gathered information after completion of the analysis.

Note: The mtu Advanced Fluid Management System works together with independent test laboratories accredited according to ISO 17025 A2LA. This accreditation is the highest level of quality obtainable by a test laboratory in North America.

5 NO_x Reducing Agent AUS 32 / AUS 40 for SCR Exhaust Gas Aftertreatment Systems

5.1 General information

SCR (Selective Catalytic Reduction) catalysts can be used for NO_x emissions reduction. The reducing agent (urea-water solution with an urea concentration of 32.5% or 40%) in such catalysts reduces the nitrogen oxide emissions.

To ensure efficient operation of the exhaust gas aftertreatment system, compliance of the reducing agent with the quality requirements stipulated in DIN 70070 / ISO 222 41-1 or ISO 18611-1 is mandatory.

With ISO 18611-1, the cleanness requirements (→ Table 32) that deviate from the standard must be observed.

In Europe, this reducing agent is often offered under the brand name “AdBlue”.

The test methods to determine the quality and characteristics of the reducing agent are specified in the standards DIN 70071 / ISO 222 41-2 / ISO 18611-2. The following table (→ Page 81) shows the quality characteristics and associated test procedures for reducing agents (extract from the standard ISO 222 41-1 and ISO 18611-1).

mtu SCR systems are usually designed for a concentration of 32.5 % urea.

For Series 2000 marine engines with SCR (12V2000M41A IMO III / 2000Mx7), the use of the NO_x reducing agent with 40% (AUS40) is also permitted.

For Series 4000 marine engines with SCR, Series 4000 M03 (8V4000M63 IMO III / 12V4000M73L, M93, M93L / 16V4000M73, M73L, M93 / 20V4000M73L, M93 / 20V4000M53B IMO III) and Series 4000 M05, the use of the NO_x reducing agent with 40% urea (AUS40) is also permitted.

Important

The purity requirements for the reducing agent then correspond to those in the standards for AUS 32 / AUS 40 (in accordance with ISO 222 41-1 or ISO 18611-1, see table (→ Page 81)).

The use of AUS 32 or AUS 40 with a lower purity level can lead to shortened maintenance intervals for the SCR substrates.

A mixture in the tank of 32.5% and 40% reducing agent is permitted for the above-mentioned engines.

Important

The use of antifreeze additives for AUS 32 and AUS 40, or so-called winter urea, is generally not approved.

Quality parameters and test procedures for reducing agent AUS 32 / AUS 40

	Unit	Test method ISO	Limit values for AUS 32	Limit values for AUS 40
Urea content	by weight %	18611-2 Annex B	31.8 - 33.2	39 - 41
Spec. gravity at 20 °C	kg/m ³	3675 12185	1087.0 - 1092.0	1105 - 1177
Refractive index at 20 °C		18611-2 Annex C	1.3817 - 1.3840	1.3947 - 1.3982
Alkalinity as NH ₃	by weight %	18611-2 Annex D	Max. 0.2	Max. 0.5
Biuret content	by weight %	22241-2 Annex E	Max. 0.3	Max. 0.3

	Unit	Test method ISO	Limit values for AUS 32	Limit values for AUS 40
Aldehyde content	mg/kg	22241-2 Annex F	Max. 5	Max. 5
Non-soluble constituents	mg/kg	22241-2 Annex G	Max. 20	Max. 20
Phosphate content as P ₀₄	mg/kg	22241-2 Annex H	Max. 0.5	Max. 0.5
Metal contents		22241-2 Annex I		
Calcium	mg/kg		Max. 0.5	Max. 0.5
Iron	mg/kg		Max. 0.5	Max. 0.5
Copper	mg/kg		Max. 0.2	Max. 0.2
Zinc	mg/kg		Max. 0.2	Max. 0.2
Chrome	mg/kg		Max. 0.2	Max. 0.2
Nickel	mg/kg		Max. 0.2	Max. 0.2
Aluminum	mg/kg		Max. 0.5	Max. 0.5
Magnesium	mg/kg		Max. 0.5	Max. 0.5
Sodium	mg/kg		Max. 0.5	Max. 0.5
Potassium	mg/kg		Max. 0.5	Max. 0.5
Identity		ISO 22241-2 Annex J	Identical with the reference sample	Identical with the reference sample

Table 33:

Storage of reducing agent

For instructions on storage, packing, transport and suitable/unsuitable materials in the reducing agent circuit, refer to the standard ISO 222 41-3 or ISO 18611-3. The instructions of the manufacturer must be observed.

Important

AUS 32 (AdBlue) crystallizes at -11 °C.

AUS 40 (AdBlue) crystallizes at 0 °C.

Avoid direct sunlight because it promotes the occurrence of microorganisms and the decomposition of the reducing agent.

6 Approved Engine Oils and Lubricating Greases

6.1 Single-grade oils – Category 1, SAE grades 30 and 40 for diesel engines

For details and special properties, see chapter “Lubricants for four-cycle engines” (→ Page 8)

Single-grade oils

Important

¹⁾ = No longer included in portfolio. Remaining stocks of this product can be used up as long as the shelf life has not expired

Single-grade oils – Category 1, SAE grades 30 and 40 for diesel engines						
Manufacturer	Brand name	SAE viscosity grade	TBN			Comments
			8 to 10 mgKOH/g	10 to 12 mgKOH/g	>12 mgKOH/g	
Addinol Lube Oil	Addinol Marine MS4011	40	X			¹⁾
	Addinol Turbo Diesel MD305	30		X		¹⁾
	Addinol Turbo Diesel MD405	40		X		¹⁾
Aegean Oil SA	Vigor Super D	40	X			¹⁾
Castrol Ltd.	Castrol MLC	30, 40		X		
Cepsa Lubricantes	Cepsa Rodaje Y Proteccion	30	X			Enhanced corrosion protection ¹⁾
Gulf Oil International	Gulf Superfleet	40	X			
LPC S.A.	Cyclon D Prime	30, 40	X			
Motor Oil (Hellas)	EMO Turbo Champion Plus	30, 40	X			
	EMO Turbo Champion	40		X		
Petrobras Distribuidora S.A.	Marbrax CCD-310	30		X		
	Marbrax CCD-410	40		X		
PT. Pertamina Lubricants	Meditiran SMX	40	X			
PTT Public Comp.	PTT Navita MTU Type 1	40	X			¹⁾
Repsol Lubricantes y Especialidades, S.A.	REPSOL GIANT 1020	30, 40		X		
	Repsol Marino 3	30		X		
	Repsol Marino 3 SAE 40	40			X	
SRS Schmierstoff Vertrieb GmbH	SRS Rekord 30	30		X		¹⁾
	SRS Rekord 40	40		X		¹⁾

Single-grade oils – Category 1, SAE grades 30 and 40 for diesel engines

Manufacturer	Brand name	SAE viscosity grade	TBN			Comments
			8 to 10 mgKOH/g	10 to 12 mgKOH/g	>12 mgKOH/g	
Shell International Petroleum Company	Shell Gadinia S3	30, 40		X		1)
	Shell Rimula R3+	30	X			
	Sirius	30	X			1)
	Shell Sirius Monograde	30, 40	X			1)
Total Lubrifiants	Total Caprano TD 30	30		X		1)
	Total Caprano TD 40	40		X		1)
United Oil	XD 7000 Extra Duty-3U		X			1)
	XD 7000 Extra Duty-4U		X			1)

Table 34:

6.2 Multi-grade oils – Category 1, SAE grade 15W-40 for diesel engines

For details and special properties, see chapter “Lubricants for four-cycle engines” (→ Page 8).

Important

¹⁾ = No longer included in portfolio. Remaining stocks of this product can be used up as long as the shelf life has not expired.

²⁾ = Engine oils marked ²⁾ are also approved for Series 60 engines

Multi-grade oils

Multi-grade oils – Category 1, SAE grade 15W-40 for diesel engines						
Manufacturer	Brand name	SAE viscosity grade	TBN			Comments
			8 to 10 mgKOH/g	10 to 12 mgKOH/g	>12 mgKOH/g	
Advanced Lubrication Specialties	Translub 15W40 CI-4	15W-40		X		¹⁾
BP p.l.c.	BP Vanellus Multi	15W-40	X			¹⁾
ENI S.p.A	eni i-Sigma universal DL	15W-40	X			
Exxon Mobil Corporation	Mobil Delvac Super 1400E	15W-40	X			¹⁾
Exxon Mobil Corporation	Mobil Delvac XHP	15W-40	X			¹⁾
Gulf Oil International	Gulf Superfleet	15W-40	X			¹⁾
Manufacture Zavod imeni Shau-myana	M5z/14D ₂ CE	15W-40			X	
Petrogal, S.A.	Galp Galaxia Super 15W-40	15W-40	X			¹⁾
Total Lubrifiants	Total Caprano TD	15W-40	X			¹⁾
Unil Opal	Intercooler 400	15W-40	X			
United Oil	XD 9000 Ultra Diesel-U	15W-40	X			¹⁾

Table 35:

6.3 Single-grade oils – Category 2, SAE grades 30 and 40 for diesel engines

For details and special properties, see chapter “Lubricants for four-cycle engines” (→ Page 8).

Important
<p>¹⁾ = No longer included in portfolio. Remaining stocks of this product can be used up as long as the shelf life has not expired.</p> <p>For Series 8000 engines, the approved SAE grade 40 engine oils may only be used in conjunction with pre-heating and oil priming ($T_{oil} > 30\text{ °C}$).</p>

Single-grade oils

Single-grade oils – Category 2, SAE grades 30 and 40 for diesel engines						
Manufacturer	Product/Brand name	SAE viscosity grade	TBN			Comments
			8 to 10 mgKOH/g	10 to 12 mgKOH/g	>12 mgKOH/g	
Rolls-Royce Solutions GmbH	Power Guard® DEO SAE 40	40	X			20 l canister: X00062816 210 l canister X00062817
Rolls-Royce Solutions America Inc.	Power Guard® SAE 40 Off-Highway Heavy Duty	40		X		5 gallons: 23532941 55 gallons: 23532942 Approved for Series 8000 Available from Rolls-Royce Solutions America Inc. Not approved for Series 2000 M72
mtu India Pvt Ltd.	Diesel Engine Oil DEO SAE 40	40		X		50 l canister: 73333/P 205 l canister: 75151/D ¹⁾ Sale of Indian oil only intended on Indian market
Addinol Lube Oil GmbH	Addinol Turbo Diesel MD 407	40	X			¹⁾
Adnoc Distribution	ADNOC Voyager Plus 40 CF/SL	40	X			¹⁾
Atak Madeni Yag Lubricants	Protector MX 30	30			X	¹⁾
	Protector MX 40	40			X	¹⁾
BayWa AG	Tectrol HD 30	30		X		
	Tectrol HD 40	40		X		
Belgin Madeni Yaglar	Lubex Marine M	30		X		¹⁾
	Lubex Marine M	40		X		¹⁾
	Lubex Marine LTM-30	30		X		
	Lubex Marine LTM-40	40		X		
	BELGIN LUBEX MARINE LTX Plus 30	30		X		
	BELGIN LUBEX MARINE LTX Plus 40	40		X		

TBM-ID: 000018996 - 013

Single-grade oils – Category 2, SAE grades 30 and 40 for diesel engines						
Manufacturer	Product/Brand name	SAE viscosity grade	TBN			Comments
			8 to 10 mgKOH/g	10 to 12 mgKOH/g	>12 mgKOH/g	
Castrol Ltd.	Castrol HLX	30, 40		X		Approved for fast commercial vessels up to 1500 h, Series 595, 1163 Approved for Series 8000 ¹⁾
Cepsa Lubricants	Cepsa Petrel HDL 40	40			X	¹⁾
Chevron Lubricants (Texaco)	Delo 400	30, 40		X		Approved for Series 8000
	Delo Gold	40		X		
Chevron – Lyteca – (Texaco)	Ursa Premium TDX	40		X		¹⁾
Delek	Delkol Super Diesel	40		X		
	Delkol Super Diesel MT Mono	40	X			
EKO ABEE	EKO MARINE MT 40	40		X		
ENOC Marketing L.L.C.	ENOC Strata Super Duty	40		X		¹⁾
ESSO Deutschland GmbH	Mobil Delvac Legend 1630	30			X	
Exxon Mobil Corporation	Mobil Delvac 1630	30		X		Not approved for Series 2000 M72 Approved for Series 8000
	Mobil Delvac 1640	40		X		Not approved for Series 2000 M72 Approved for Series 8000
	Mobil Delvac Legend 1640	40		X		Not approved for Series 2000 M72
	Mobilgard ADL 30	30		X		Not approved for Series 2000 M72 Approved for Series 8000
	Mobilgard ADL 40	40		X		Not approved for Series 2000 M72 Approved for Series 8000
Fuchs Lubrifiant France s. a.	MARINE OTAN O-28 OMD 113	40			X	
Fuchs Petrolub SE	Titan Universal HD	30, 40	X			¹⁾
	Titan EM 30 MTU	30	X			Enhanced corrosion protection
	Titan Universal HD SAE 30 mtu	30	X			Enhanced corrosion protection
Gulf Oil International	Gulf Superfleet Plus	40	X			
Gulf Western Oil, Australia	Turboil	40			X	¹⁾
GS Caltex Corporation	Kixx D1 40	40	X			¹⁾
	MPA 300 SAE 30	30	X			
	MPA 300 SAE 40	40	X			

TIM-ID: 00001896 - 013

Single-grade oils – Category 2, SAE grades 30 and 40 for diesel engines

Manufacturer	Product/Brand name	SAE viscosity grade	TBN			Comments
			8 to 10 mgKOH/g	10 to 12 mgKOH/g	>12 mgKOH/g	
Hyrax Oil Sdn Bhd	Hyrax Top Deo	40	X			1)
Koçak Petrol Ürünleri San. ve. TIC. Ltd.	Speedol Ultra HDX 30 TBN 12	30		X		1)
	Speedol Ultra HDX 40 TBN 12	40		X		1)
	Speedol Deniz Dizel Motor Yağı	30, 40		X		
	Speedol Ultra HDX	30, 40	X			1)
Kuwait Petroleum	Q8 T 750	30, 40	X			
LPC s. a.	Cyclon D Super	40		X		
Manufacture Zavod imeni Shau-myana Ltd.	M-14D2CE	40			X	
Motor Oil, Hellas	EMO SHPD Plus	30, 40		X		
Motorex AG	Motorex Monolube	30		X		
Oryx Energies	Supreme RR	40			X	1)
Panolin AG	Panolin Extra Diesel	40	X			1)
Paz Lubricants & Chemicals	Pazl Marine S 40	40	X			1)
Petrobras Distribuidora s. a.	Marbrax CCD-310-AP	30		X		1)
Petrogal, s. a.	Galp Galaxia 40	40		X		1)
Prista Oil Holding EAD	Prista SHPD 40	40			X	1)
PTT Public Comp.	PTT Navita mtu Type 2	40		X		1)
	Navita Plus, SAE 40	40		X		1)
Repsol Lubricantes y Especialidades, s. a.	Repsol Diesel Serie 3 MT	40			X	1)
Shell International Petroleum Company	Shell Sirius X	30			X	1) Approved for Series 8000
	Shell Sirius X	40			X	1) Approved for Series 8000
Sonol	Seamaster 40	40	X			
SRS Schmierstoff Vertriebs GmbH	SRS Rekord plus 30	30		X		
	SRS Rekord plus 40	40		X		
	SRS Antikorrol M plus	30		X		Enhanced corrosion protection Only permitted for running-in and series acceptance
	SRS Motorenöl O-278	40		X		

Single-grade oils – Category 2, SAE grades 30 and 40 for diesel engines						
Manufacturer	Product/Brand name	SAE viscosity grade	TBN			Comments
			8 to 10 mgKOH/g	10 to 12 mgKOH/g	>12 mgKOH/g	
Total Lubrifiants	Total Caprano MT 30	30			X	¹⁾
	Total Caprano MT 40	40			X	¹⁾
	Total Disola MT 30	30	X			¹⁾
	Total Disola MT 40	40	X			¹⁾
	Total Rubia MT 30	30			X	¹⁾
	Total Rubia MT 40	40			X	¹⁾
Viva Energy Australia	Penske Power Systems Premium	40			X	¹⁾

Table 36:

6.4 Multi-grade oils – Category 2, SAE grades 10W-30, 10W-40, 15W-40 and 20W-40 for diesel engines

For details and special properties, see chapter “Lubricants for four-cycle engines” (→ Page 8).

Important
<p>¹⁾ = No longer included in portfolio. Remaining stocks of this product can be used up as long as the shelf life has not expired.</p> <p>²⁾ Engine oils marked ²⁾ are also approved for Series 60 engines.</p>

Multi-grade oils

Multi-grade oils – Category 2, SAE grades 10W-30, 10W-40, 15W-40 and 20W-40 for diesel engines						
Manufacturer	Product/Brand name	SAE viscosity grade	TBN			Comments
			8 to 10 mgKOH/g	10 to 12 mgKOH/g	>12 mgKOH/g	
Rolls-Royce Solutions GmbH	DEO SAE 15W-40 Ultra	15W-40		X		20 l canister: X00084315 210 l barrel: X00084316
	Diesel Engine Oil DEO SAE 15W-40 ¹⁾	15W-40		X		Product replaced by DEO SAE 15W-40 Ultra.
Rolls-Royce Solutions Asia Pte. Ltd.	Diesel Engine Oil - DEO 15W-40	15W-40		X		20 l canister: 64242/P 205 l canister: 65151/D
Rolls-Royce Solutions Suzhou Co. Ltd. China	Diesel Engine Oil - DEO SAE 15W-40	15W-40		X		20 l canister: X00064242/P 205 l canister: 65151/D
	Diesel Engine Oil - DEO SAE 10W-40	10W-40		X		20 l canister: 60606/P
PT. Rolls-Royce Solutions Indonesia	Diesel Engine Oil - DEO SAE 15W-40	15W40		X		20 l canister: X00064242/P 205 l canister: 65151/D
mtu India Pvt. Ltd.	Diesel Engine Oil - DEO 15W-40	15W-40		X		50 l canister: 63333/P ²⁾ 205 l canister: 65151/D Sale only intended in Indian market
Adnoc Distribution	Adnoc Voyager Plus	15W-40		X		¹⁾ ²⁾
Aegean Oil S.A.	Vigor Turbo SD 15W-40	15W-40	X			²⁾
Addinol Lube Oil	Addinol Super Longlife MD1047	10W-40		X		¹⁾
	Addinol Diesel Longlife MD1548	15W-40		X		¹⁾ ²⁾
AP Oil	AP X-Super Dieselube Turbo CF-4	15W40	X			
Arabi Eneritech KSC	Burgan Ultra Diesel CH-4	15W-40		X		¹⁾ ²⁾
Aral AG	Aral Turboral	10W-40		X		
	Aral Turboral	15W-40		X		¹⁾ ²⁾

TIN-ID: 000019001 - 014

Multi-grade oils – Category 2, SAE grades 10W-30, 10W-40, 15W-40 and 20W-40 for diesel engines						
Manufacturer	Product/Brand name	SAE viscosity grade	TBN			Comments
			8 to 10 mgKOH/g	10 to 12 mgKOH/g	>12 mgKOH/g	
Aramco Lubricants and Retail Company	Orizon HD vB	15W-40	X			2)
	Orizon HD vE	15W-40		X		2)
Atak Madeni Yağ Paz.San.Tic.Aş	Alpet Turbot	10W40		X		1)
	Alpet Turbot Fleetmax	15W-40		X		1)
	Alpet Turbot SHPD	15W-40		X		1)
	Alpet Turbot XHD	10W-40		X		1)
Auto-Teile-Ring GmbH	Cartechnic Motorenöl SAE 15W-40	15W-40	X			1)
AVIA AG	AVIA TURBOSYNTH CFE 10W-40	10W-40		X		1)
Avista Oil Refining & Trading Deutschland GmbH	Avista Advantage SHPD	15W-40	X			1)
	Avista Advantage UHPD	15W-40	X			1)
	Pennasol Turbo Super	15W-40		X		1) 2)
	MOTOR GOLD Turbotec	15W-40		X		1) 2)
Avista Oil Deutschland GmbH	AVISTA pure EVO CI-4 KS SAE	15W-40		X		1) 2)
Bahrain Petroleum Company B.S.C.	Frontier Megatek	10W-40	X			1)
	Frontier Super Plus	15W-40		X		1) 2)
	Frontier Turbo	15W-40		X		1)
	Frontier Turbo LD	10W-40		X		1)
	Frontier Turbo Plus	15W-40		X		1) 2)
BayWa AG	Tectrol Turbo 4000	10W-40		X		
	Tectrol Super Truck 1540	15W-40			X	
Belgin Madeni Yaglar	BELGIN LUBEX ROBUS PRO 15W-40	15W-40		X		2)
	LUBEX MARINA M	15W-40		X		

TIN-ID: 000019001 - 014

Multi-grade oils – Category 2, SAE grades 10W-30, 10W-40, 15W-40 and 20W-40 for diesel engines

Manufacturer	Product/Brand name	SAE viscosity grade	TBN			Comments
			8 to 10 mgKOH/g	10 to 12 mgKOH/g	>12 mgKOH/g	
BP p.l.c.	BP Vanellus C6 Global Plus	10W-40		X		1)
	BP Vanellus Multi-Fleet	15W-40			X	1) 2)
	BP Multi Mine	15W-40	X			1) 2)
	BP Mine Multi 15W-40	15W-40		X		1) 2)
	BP Vanellus Longdrain	15W-40		X		1) 2)
	BP Vanellus Multi A	10W-40		X		1) 2)
	BP Vanellus Agri	10W-40		X		1) 2)
	BP Vanellus Multi A	15W-40		X		2)
	BP Vanellus Agri	15W-40	X			1) 2)
	BP Vanellus Max Extra	15W-40			X	1) 2)
Castrol Ltd.	Castrol CRB Multi 10W-40 CI-4/E7	10W-40		X		1)
	Castrol CRB Multi 15W-40 CI-4/E7	15W-40		X		2)
	Castrol CRB Turbo 15W-40 CH-4/E7	15W-40	X			1) 2)
	Castrol CRB Turbomax 15W-40 CI-4/SL/E7	15W-40		X		2)
	Castrol Rivermax CRB 15W-40 CI-4/E7	15W-40		X		2)
	Castrol Rivermax RX+ 15W-40	15W-40	X			1) 2)
	Castrol Vecton 15W-40 DH-1	15W-40			X	1) 2)
	Castrol RX Diesel	15W-40	X			
	Castrol RX Diesel 15W-40 CI-4/E7	15W-40		X		1) 2)
	Castrol Vecton	10W-40		X		1)
	Castrol Vecton 15W-40 CI-4/E7	15W-40		X		1) 2)
	Castrol Vecton 15W-40 CI-4 Plus/SL/E7				X	2)
Cepsa	Cepsa Euromax SHPD	15W-40		X		1) 2)

TIM-ID: 000019001 - 014

Multi-grade oils – Category 2, SAE grades 10W-30, 10W-40, 15W-40 and 20W-40 for diesel engines						
Manufacturer	Product/Brand name	SAE viscosity grade	TBN			Comments
			8 to 10 mgKOH/g	10 to 12 mgKOH/g	>12 mgKOH/g	
Cepsa Comercial Petroleo S.A.U.	Traction Max SAE 15W-40	15W-40		X		2)
Champion Chemicals N.V.	Champion New Energy	15W-40		X		2)
Chevron Lubricants (Caltex)	Delo Gold Multigrade SAE 15W-40	15W-40	X			
	Delo Gold Ultra	15W-40		X		2)
	Delo Gold Ultra E	10W-40		X		
	Delo Gold Ultra E	15W-40	X			2)
	Delo 400 Multigrade	15W-40			X	1) 2)
	OEC	15W-40		X		1)
Chevron Lubricants (Texaco)	Ursa Super TD SAE 15W-40	15W-40		X		2)
	Ursa Premium TDX	15W-40		X		2)
	Ursa Premium TDX Plus	15W-40		X		1) 2)
	Ursa Heavy Duty	15W-40	X			
CPC Corporation, Taiwan	CPC Superfleet CG4 Motor Oil	15W-40	X			
	CPC MARILUBE OIL 9250M	15W-40	X			
Cubalub	Cubalub Extra Diesel MX	15W-40			X	1) 2)
	Cubalub Extra Diesel	15W-40	X			1)
Delek	Delkol Super Diesel	15W-40	X			
Delek Industries Ltd.	Super Diesel	15W-40		X		
Dunwell Petro-Chemical Co., Ltd.	Apex Super Motor Oil SL/CI-4, 15W-40	15W-40		X		2)
EKO ABEE	Eko Forza plus	15W-40	X			
	EKO Marine Plus 15W-40	15W-40	X			2)
	EKO Marine Premium 15W-40	15W-40		X		2)
Engen Petroleum Ltd.	Engen Dieselube 600 Super	15W-40	X			1) 2)
	Engen Dieselube 700 Super	15W-40		X		1) 2)
eni S.p.A.	eni i-Sigma super fleet	15W-40		X		1)
	eni i-Sigma performance E3	15W-40	X			1)
	eni i-Sigma performance E7	15W-40		X		1) 2)
	eni i-Sigma performance E7	15W-40	X			1) 2)
Euroiltecnology Co., Ltd. I	Casoku	15W-40	X			1)

TIM-ID: 000019001 - 014

Multi-grade oils – Category 2, SAE grades 10W-30, 10W-40, 15W-40 and 20W-40 for diesel engines

Manufacturer	Product/Brand name	SAE viscosity grade	TBN			Comments
			8 to 10 mgKOH/g	10 to 12 mgKOH/g	>12 mgKOH/g	
ESSO Deutschland GmbH	MOBIL DELVAC MODERN 15W-40 EXTREME DEFENSE	15W-40		X		2)
Exol Lubricants Ltd.	Taurus Extreme M	15W-40	X			1) 2)
	Taurus Extreme HST	15W-40		X		2)
Exxon Mobil Corporation	Mobilgard HSD 15W-40 CH-4	15W-40	X			
	Mobilgard HSD 15W-40 CI-4	15W-40		X		2)
	Mobilgard 1 SHC	20W-40			X	Approved for fast commercial vessels up to 1500 h, 396, 1163
	Mobil Delvac Mining 15W-40	15W-40		X		2)
	Mobil Delvac Super 1300 C	15W-40	X			
	Mobil Delvac Super 1400	15W-40	X			
	Mobil Delvac Modern 15W-40 Super Defense	15W-40	X			2)
	Mobil Delvac Modern 15W-40 Super Defense Mine V2	15W-40		X		2)
	Mobil Delvac Modern 15W-40 Super Defense V3	15W-40	X			
	Mobil Delvac MX	15W-40			X	2)
	Mobil Delvac MX Extra	10W-40		X		
	Mobil Delvac Advanced City Logistics	15W-40	X			
	Mobil Delvac Legend CH-4 15W-40 Heavy Duty	15W-40	X			1)
Finke Mineralölwerk GmbH	AVIATICON Turbo Super	15W-40	X			2)
	AVIATICON Turbo D 10W-40	10W-40		X		
Formosa Petrochemical Corporation	Formosa Marine Fleet XMT	15W-40	X			1)
Fuchs	TITAN SHPD SAE 15W-40	15W-40		X		2)
Fuchs Lubrifiants France	Cofran Plura Super	15W-40		X		1) 2)

TIM-ID: 000019001 - 014

Multi-grade oils – Category 2, SAE grades 10W-30, 10W-40, 15W-40 and 20W-40 for diesel engines						
Manufacturer	Product/Brand name	SAE viscosity grade	TBN			Comments
			8 to 10 mgKOH/g	10 to 12 mgKOH/g	>12 mgKOH/g	
Fuchs Petrolub SE	Fuchs Max Way	15W-40	X		2)	
	Pentotruck	15W-40	X		2)	
	Fuchs Titan Truck	15W-40	X		2)	
	Fuchs Titan Truck Plus	10W-30	X			
	Fuchs Titan Truck Plus	15W-40	X		2)	
	Fuchs Titan Unimax Plus MC	10W-40	X			
	Fuchs Titan Unimax Ultra MC	10W-40	X			
	Fuchs Titan Universal HD	15W-40	X		1)	
	MTU DEO SAE 15W-40 ULTRA	15W-40		X	2)	
	TITAN TRUCK PLUS SAE 15W-40	15W-40	X		2)	
German Mirror Lubricants and Greases Co. FZE	Mirr Turbo Plus Diesel Engine Oil API CI-4 SAE 10W-40	10W-40	X		1)	
	Mirr Turbo Plus Diesel Engine Oil API CI-4 SAE 15W-40	15W-40	X		1) 2)	
	Mirr Turbo Diesel Engine Oil API CH-4 SAE 15W-40	15W-40	X		1) 2)	
Ginouves Georges SAS	York 849	15W-40	X		1) 2)	
Glide Technology SDN BHD	MonsterGlide Hyper F SAE 15W-40 API CI-4/SL	15W-40	X		2)	
GS Caltex India Private Limited	Kixx Dynamic Gold	15W-40	X		1) 2)	
GS Caltex Corporation	Kixx HD 1	10W-40	X		1)	
	Kixx HD 1	15W-40	X		1) 2)	
Gulf Oil International	Gulf Super Duty VLE	15W-40	X			
	Gulf Supreme Duty LE	15W-40	X		1)	
	Gulf Superfleet LE	10W-40	X		1)	
	Gulf Superfleet LE	15W-40	X		2)	
	Gulf Superfleet Supreme	10W-40	X			
	Gulf Superfleet Supreme	15W-40	X		1) 2)	
	Gulf Superfleet Plus	15W-40	X		1)	
Gulf Oil Marine Ltd.	GulfSea Power MX 15W-40	15W-40	X		2)	
Gulf Western Oil,Australia	TOP DOG XDO	15W-40	X		1) 2)	

TIN-ID: 000019001 - 014

Multi-grade oils – Category 2, SAE grades 10W-30, 10W-40, 15W-40 and 20W-40 for diesel engines

Manufacturer	Product/Brand name	SAE viscosity grade	TBN			Comments
			8 to 10 mgKOH/g	10 to 12 mgKOH/g	>12 mgKOH/g	
Hafa France	Stradex 1800	10W-40		X		1)
Hellenic Fuels and Lubricants Single Member Industrial and Commercial S.A. (EKO ABOEE)	EKO FORZA PREMIUM 15W-40	15W-40		X		2)
Hessol Lubrication GmbH	Hessol Turbo Diesel	15W-40		X		2)
	Hessol Super Longlife	10W-40		X		
High Industrial Lubricants & Liquids Corporation (HILL)	Fastroil Force F300 Diesel	15W-40		X		1) 2)
	Fastroil Force F500 Diesel	15W-40		X		1) 2)
Hindustan Petroleum	HP MILCY MTU 15W-40	15W-40		X		2)
Hitachi Construction Machinery CO., Ltd.	Hitachi Premium Orange	15-W40	X			1)
Huiles Berliet S.A.	RTO Maxima RD	15W-40	X			1) 2)
	RTO Maxima RLD	15W-40		X		1) 2)
Hyrax Oil Sdn Bhd	Ceypetco Enduro	15W-40		X		1) 2)
	Hyrax Admiral 15W-40	15W-40	X			2)
INA Maziva Ltd.	INA Super Max	15W-40		X		2)
Indian Oil Corporation Limited	Servo Premium (N)	15W-40		X		1)
	Servo Premium (N) 15W-40	15W-40		X		2)
	Servo Pride Supreme XL	15W-40		X		2)
Ipiranga Produtos des Petróleo S.A.	Ipiranga Brutus Alta Performance	15W-40		X		1) 2)
Kuwait National Lube Oil MfgCo (KNLOC)	Burgan Ultra Diesel CH-4	15W-40		X		1) 2)
Kuwait Petroleum	Q8 T 750	15W-40	X			2)
	Q8 T 800	10W-40	X			2)
Kocak Petrol Ürünleri San	Speedol SHPD Tirot 15W-40	15W-40		X		
LAUGFS Lubricants Limited	D-TRON ACTIVTECH, SAE 15W 40, API CI-4	15W-40		X		
Liqui Moly GmbH	Liqui Moly Marine 4T Motor Oil	15W-40		X		2)
	Liqui Moly Touring High Tech SHPD	15W-40		X		2)

T/M-ID: 000019001 - 014

Multi-grade oils – Category 2, SAE grades 10W-30, 10W-40, 15W-40 and 20W-40 for diesel engines						
Manufacturer	Product/Brand name	SAE viscosity grade	TBN			Comments
			8 to 10 mgKOH/g	10 to 12 mgKOH/g	>12 mgKOH/g	
Lotos Oil	Turdus Powertec CI-4 15W-40	15W-40		X		1) 2)
	Turdus Powertec 1000	15W-40		X		2)
LPC S.A.	Cyclon D Super	15W-40	X			
	Cyclon Granit Maximum	15W-40		X		1) 2)
Lubricantes de América	Generac Aceite	15W-40		X		
	Lubral Nano Diesel	15W-40		X		
	Lubral Nano Diesel SAE 5W-40 API CI-4 Plus / SL	15W-40		X		2)
Lubrisa	Gulf Superfleet Supreme	15W-40		X		1) 2)
Mabanol GmbH & Co. KG	Mabanol Argon Fleet	15W-40	X			1)
Mega Lube Marketers cc.	Megalube Diesel Engine Oil	15W-40		X		1)
Modriča Oil Refinery	Maxima Turbo	15W-40		X		1)
MOL-LUB Kft..	MOL MK-9	15W-40		X		1)
	Mol Dynamic Super Diesel	15W-40	X			1)
	Mol Transit 10W-40	10W-40		X		1)
	Mol Transit 15W-40	15W-40		X		1) 2)
	Mol Dynamic Transit	15W-40		X		1) 2)
	MOL Super Diesel	15W-40	X			1)
Morris Lubricants Limited	Versimax HD4	15W-40		X		1) 2)
Motorex AG	Motorex Universal	10W40		X		1)
Motor Oil, Hellas	EMO SHPD Plus	15W-40		X		
MPM International Oil Company B.V.	Motor Oil 15W-40 Super High Performance	15W-40		X		1) 2)
NetLube Iran	Max Turbo	15W-40		X		1) 2)
NSL OilChem Trading Pte Ltd	Liquid Gold D-Flo X4	15W-40		X		1) 2)
Oman Oil Marketing Company SAOG	Omanoil Maximo Super 15W40 CH-4	15W-40	X			1) 2)

TIN-ID: 000019001 - 014

Multi-grade oils – Category 2, SAE grades 10W-30, 10W-40, 15W-40 and 20W-40 for diesel engines

Manufacturer	Product/Brand name	SAE viscosity grade	TBN			Comments
			8 to 10 mgKOH/g	10 to 12 mgKOH/g	>12 mgKOH/g	
Orlen Oil	Mogul Diesel DTT Extra	15W-40			X	1) 2)
	Platinum Ultor	15W-40	X			1) 2)
	Platinum Ultor Plus	15W-40			X	1) 2)
Oryx Energies	Enduro 600	15W-40		X		
Panolin AG	Panolin Diesel Synth	10W-40		X		1)
PDVSA CA	PDV Ultradiesel	15W-40		X		1) 2)
PETROBRAS DISTRIBUIDORA S.A.	LUBRAX NAUTICA DIESEL	15W-40		X		1) 2)
	LUBRAX TOP TURBO	15W-40		X		2)
PetroChina Lubricant Company	Tianwei CH-4 15W-40 diesel engine	15W-40	X			2)
Petrogulf Oil Manufacturing LLC	Paramount Extreme Action 15W40 CI-4	15W-40		X		1) 2)
Petrolgal, S.A.	Galp Galaxia LD star	15W-40		X		1)
Petrol Ofisi A.Ş	Petrol Ofisi Maximus Turbo Diesel Extra	15W-40		X		2)
Petron Corporation	Petron Rev-x Premium Multi Grade	15W-40		X		2)
Petronas Lubricants International	Petronas Urania 3000	15W-40		X		2)
	Syntium Diesel 800 15W-40	15W-40		X		1) 2)
	Urania 3000 LS 10W30	10W30	X			
	Petronas Urania LD7	15W-40		X		1)
Petromin Oils Company	Petromin Turbomaster XD	15W-40		X		2)
	Petromin Turbomaster XD 15W40 CI-4	15W-40		X		1) 2)
Phillips 66 Lubricants	Conoco Hydroclear Power D	15W-40			X	1)
Prista Oil Holding EAD	Prista Turbo Diesel	15W-40	X			1)
	Pro Auto HDEO E7 15W-40	15W-40		X		2)
PT Pertamina Lubricants	Meditran SX	15W-40		X		1) 2)
	Meditran SX Plus	15W-40		X		1)
PTT Oil and Retail Business Public Company Limited	Navita Plus	15W-40		X		2)
PTT Public Limited	Navita Plus SAE 15W-40	15W-40	X			1)

TIN-ID: 000019001 - 014

Multi-grade oils – Category 2, SAE grades 10W-30, 10W-40, 15W-40 and 20W-40 for diesel engines						
Manufacturer	Product/Brand name	SAE viscosity grade	TBN			Comments
			8 to 10 mgKOH/g	10 to 12 mgKOH/g	>12 mgKOH/g	
Puma Energy S.A.	Puma HD Plus	15W-40		X		2)
Puma Lubricants	Puma Power Motor Oil	15W-40		X		1) 2)
Qatar Lubricants Company Ltd.	QALCO Topaz HMF	15W-40	X			
Qingdao Copton Technology Co., LTD.	Copton CH-4 Diesel Engine Oil	15W-40	X			1)
Raloy Lubricantes, S.S. de C.V.	Raloy Diesel Power	15W-40		X		2)
Raj Petro Specialities P Ltd.	Zoomol Rforce 3100 RF1	15W-40	X			1) 2)
	Zoomol Rforce 3100 RF4	15W-40		X		1) 2)
RAMOIL SPA	DUGLAS OIL SUPER LIFE 15W-40 SHPDO	15W-40		X		2)
Ravensberger Schmierstoffvertrieb GmbH	RAVENOL Expert SHPD	10W-40		X		1)
	RAVENOL Turbo Plus SHPD	15W-40		X		1)
	RAVENOL Mineralöl Turbo Plus SHPD	15W-40	X			1) 2)
Repsol Lubricantes y Especialidades, S.A.	REPSOL GIANT 7530	15W-40			X	2)
	REPSOL GIANT 7410	15W-40	X			2)
ROLF Lubricants GmbH	Rolf Krafton M5 U 15W-40	15W-40		X		
ROWE Mineralölwerk GmbH	ROWE Hightec Formula GT SAE	10W-40		X		
	ROWE Hightec Formula GT SAE 10W-40 HC	10W-40		X		
	ROWE Hightec Turbo HD 15W-40 Plus	15W-40		X		2)
S.A.E.L.	Gulf Gulfleet Long Road	15W-40	X			1)

Multi-grade oils – Category 2, SAE grades 10W-30, 10W-40, 15W-40 and 20W-40 for diesel engines

Manufacturer	Product/Brand name	SAE viscosity grade	TBN			Comments
			8 to 10 mgKOH/g	10 to 12 mgKOH/g	>12 mgKOH/g	
Shell International Petroleum Company	Shell HD4 CHN	15W-40		X		2)
	Shell Fleet CI-4					
	Shell Rimula MV	15W-40			X	1) 2)
	Shell Rimula R3 MV	15W-40	X			2)
	Shell Rimula R3 X	15W-40		X		1) 2)
	Shell Rimula R4	15W-40		X		2)
	Shell Rimula R4 Multi	15W-40		X		
	Shell Rimula R4 Plus	15W-40		X		2)
	Shell Rimula R4 X	15W-40		X		2)
	Shell Rimula RT4	15W-40		X		1) 2)
	Shell Rimula RT4 X	15W-40		X		2)
	Shell Rimula T3	15W-40		X		1) 2)
	Shell Rimula T4	15W-40		X		2)
	Shell Rotella T2	15W-40		X		1)
	Shell Rotella T Multigrade	15W-40		X		1) 2)
	Shell Sirius S4	15W-40		X		1) 2)
	Eicher Premium Plus Diesel Engine Oil	15W-40		X		2)
Singapore Petroleum Company Limited	SDM 900 SAE 15W40	15W-40		X		
Sinopec Lubricant Co., Ltd.	Sinopec Tulux T500	15W-40		X		2)
SK Lubricants Co. Ltd.	ZIC X5000 10W-40	10W-40		X		1)
	ZIC X5000	15W-40	X			1) 2)
	ZIC X7000 CI-4 10W-40	10W-40		X		1)
	ZIC X7000 CI-4	15W-40	X			1) 2)

TIN-ID: 000019001 - 014

Multi-grade oils – Category 2, SAE grades 10W-30, 10W-40, 15W-40 and 20W-40 for diesel engines						
Manufacturer	Product/Brand name	SAE viscosity grade	TBN			Comments
			8 to 10 mgKOH/g	10 to 12 mgKOH/g	>12 mgKOH/g	
SRS Schmierstoff Vertrieb GmbH	SRS Motorenöl O-236	15W-40	X			2) Enhanced corrosion protection
	SRS Multi-Rekord top	15W-40		X		2)
	SRS Multi Rekord plus	15W-40	X			
	SRS Turbo Rekord	15W-40	X			2)
	SRS Turbo Rekord NG	15W-40		X		2)
	SRS Cargolub TFE	15W-40		X		
	SRS Cargolub TFX	10W-40		X		
Tesla Technoproducts FZE	Denebola Saheli Ultra XS 1120	15W-40		X		1) 2)
Top 1 Oil Products Company	Top 1 Transport	15W-40		X		1) 2)
TotalEnergies Lubrifiant	Caprano TDH 15W-40	15W-40		X		
	Caprano TDI 15W-40	15W-40		X		2)
	RUBIA TIR 7400 SAE 15W-40	15W-40		X		
	Rubia Works 1000 15W-40	15W-40		X		2)
	TP MAX 10W-40	10W-40		X		
	Tractagri HDX 15W-40	15W-40				2)
Total Lubrificants	Total Caprano TDI	15W-40		X		1) 2)
	Caprano TDI FE 10W-30	10W-30		X		
	Rubia Works 1000 FE 10W-30	10W-30		X		
	Total Disola W	15W-40		X		1)
	Hitachi Genuine Engine Oil 15W40 DH-1	15W-40		X		1) 2)
UMW Grantt International Sdn Bhd	GRANTT QUASAR SAE 15W-40 API CI-4	15W-40		X		2)
Unil Opal	Medos 700	15W-40			X	2)

TIN-ID: 000019001 - 014

Multi-grade oils – Category 2, SAE grades 10W-30, 10W-40, 15W-40 and 20W-40 for diesel engines						
Manufacturer	Product/Brand name	SAE viscosity grade	TBN			Comments
			8 to 10 mgKOH/g	10 to 12 mgKOH/g	>12 mgKOH/g	
Valvoline EMEA	All-Fleet Extra SAE 15W-40	15W-40	X			2)
	All-Fleet Plus	15W-40	X			1) 2)
	NextGen All-Fleet extra	15W-40		X		1) 2)
	Premium Blue Classic	15W-40		X		1) 2)
	Valvoline All-Fleet Extra	15W-40		X		2)
	Valvoline Premium Blue 7800 15W-40	15W-40		X		1) 2)
	Valvoline Premium Blue ES 7800 SAE 15W-40	15W-40		X		1)
Veedol International Limited	VEEDOL DIESEL STAR EXTRA15W-40	15W-40		X		1) 2)
Viva Energy Australia	Penske Power Systems Premium	15W-40	X			1) 2)
Wolf Oil Corporation NV.	Wolf Vitaltech 15W40	15W-40		X		2)
Wunsch Öle GmbH	Wunsch Rekord TLM-TU 10W-40	10W-40		X		1)
YPF ZA.	Extravida XV 200	15W40		X		2)

Table 37:

6.5 Multi-grade oils – Category 2.1 (Low SAPS oils), SAE grades 0W-30, 10W-30, 5W-40, 10W-40 and 15W-40 for diesel engines

For details and special properties, see chapter “Lubricants for four-cycle engines” (→ Page 8)

Important

¹⁾ = No longer included in portfolio. Remaining stocks of this product can be used up as long as the shelf life has not expired.

²⁾ Engine oils marked ²⁾ are also approved for Series 60 engines.

Multi-grade oils

Multi-grade oils – Category 2.1 (Low SAPS oils), SAE grades 0W-30, 10W-30, 5W-40, 10W-40 and 15W-40 for diesel engines						
Manufacturer	Product/Brand name	SAE viscosity grade	TBN			Comments
			8 to 10 mgKOH/g	10 to 12 mgKOH/g	>12 mgKOH/g	
Rolls-Royce Solutions America Inc.	Power Guard® SAE 15W-40 Off-Highway Heavy Duty	15W-40	X			5 gallons: 800133 55 gallons: 800134 IBC: 800135 Available from Rolls-Royce Solutions America Inc. ²⁾
Advanced Lubrication Specialties, Inc.	Advantage Premium Plus	15W-40		X		²⁾
	Advantage Ultra Premium Plus	5W-40		X		
Aramco Lubricants and Retail Company	Orizon HD vF 15W-40	15W-40	X			²⁾
	Orizon HD vH 15W-40	15W-40	X			²⁾
BayWa AG	TETROL SUPER TRUCK PLUS XL 1040	10W-40		X		
BP p.l.c.	BP Vanellus Eco	15W-40	X			¹⁾ ²⁾
Calumet Branded Products LLC	Royal Purple Duralec Super 5W-40	5W-40		X		
	Royal Purple Duralec Super 15W-40	15W-40	X			²⁾
	Bel-Ray Hyperion Synthetic Blend	10W-30	X			
	Bel-Ray Hyperion Elite Synthetic 5W-40 CK-4	5W-40		X		
Canroyal Oil Lubricants / Dist.	Canroyal Synthetic Diesel Engine Oil	15W-40	X			²⁾

TIM-ID: 000019003 - 012

Multi-grade oils – Category 2.1 (Low SAPS oils), SAE grades 0W-30, 10W-30, 5W-40, 10W-40 and 15W-40 for diesel engines

Manufacturer	Product/Brand name	SAE viscosity grade	TBN			Comments
			8 to 10 mgKOH/g	10 to 12 mgKOH/g	>12 mgKOH/g	
Castrol Ltd.	Castrol CRB Mining 15W-40	15W-40	X			2)
	Castrol CRB Mining 15W-40 CK-4	15W-40	X			2)
	Castrol CRB Turbo G4 15W-40	15W-40	X			1) 2)
	Castrol RX Super 15W-40 CJ-4/E9	15W-40	X			2)
	Castrol Vecton 15W-40 CK-4/E9	15W-40	X			2)
Champion Chemicals N.V.	Champion OEM specific 15W40 MS	15W-40	X			2)
	Champion OEM specific 15W40 MS Extra	15W-40	X			2)
Chevron Lubricants (Chevron)	Delo 400 LE	15W-40	X			1) 2) Also approved for Series 4000-04 T
	Delo 400 LE Synthetic	5W-40		X		
	Delo 400 MGX	15W-40	X			2)
	Delo 400 SDE	15W-40	X			2)
	Delo 400 SLK	15W-40	X			2)
	Delo 400 XLE	10W-30		X		
	Delo 400 XLE	15W-40		X		1) 2)
Delo 400 XSP	5W-40		X			
Chevron Lubricants (Texaco)	Ursa Ultra LE	15W-40	X			2)

Multi-grade oils – Category 2.1 (Low SAPS oils), SAE grades 0W-30, 10W-30, 5W-40, 10W-40 and 15W-40 for diesel engines

Manufacturer	Product/Brand name	SAE viscosity grade	TBN			Comments
			8 to 10 mgKOH/g	10 to 12 mgKOH/g	>12 mgKOH/g	
ExxonMobil Corporation	Mobil Delvac 1 ESP	0W-30	X			
	Mobil Delvac 1 ESP	5W-40		X		
	Mobil Delvac Extreme	15W-40		X		
	Mobil Fleet	15W-40	X			2)
	Mobil Fleet 15W-40	15W-40	X			1)
	Mobil Delvac HDEO	15W-40	X			2)
	Mobil Delvac MX ESP 10W-40	10W-40	X			
	Mobil Delvac MX ESP V2 15W-40	15W-40	X			2)
	Mobil Delvac Modern 15W-40 Advanced Protection V1	15W-40		X		2)
	Mobil Delvac Modern 15W-40 Advanced Protection Mine	15W-40				
	Mobil Delvac Modern 15W-40 Advanced Protection Mine V2	15W-40		X		2)
	Mobil Delvac Modern 15W-40 Complete Protection	15W-40	X			2)
	Mobil Delvac Modern 15W-40 Extended Performance	15W-40	X			2)
	Mobil Delvac Modern 10W-40 Full Protection	10W-40	X			
	Mobil Delvac Modern 15W-40 Full Protection Mine V1	15W-40	X			2)
	Mobil Delvac Modern 15W-40 Full Protection Mine V2	15W-40		X		2)
	Mobil Delvac Modern 15W-40 Full Protection V2	15W-40	X			
	Mobil Delvac Ultra 5W-40 Extended Performance	5W-40		X		
	Mobil Delvac Ultra 5W-40 Ultimate Protection V1	5W-40		X		
	Mobilgard 1 HSD 5W-40	5W-40		X		
eni S.P.A.	eni i-Sigma top MS	15W-40	X			2)
Finke Mineralölwerke GmbH	AVIATICON Turbo LA Plus	10W-40	X			2)
	AVIATICON Turbo Premium ECO LA 10W-30	10W-30	X			
	AVIATICON Turbo Super Plus	15W-40	X			1) 2)
	AVIATICON Turbo Super Premium 15W-40	15W-40	X			2)

TIN-ID: 000019003 - 012

Multi-grade oils – Category 2.1 (Low SAPS oils), SAE grades 0W-30, 10W-30, 5W-40, 10W-40 and 15W-40 for diesel engines

Manufacturer	Product/Brand name	SAE viscosity grade	TBN			Comments
			8 to 10 mgKOH/g	10 to 12 mgKOH/g	>12 mgKOH/g	
Fuchs Petrolub SE	Fuchs Titan Cargo	10W-40	X			1)
	Fuchs Titan Cargo	10W-30	X			
	Fuchs Titan Cargo	15W-40	X			2)
	Titan Cargo SAE 15W-40	15W-40	X			2)
	FUCHS TITAN CARGO MAXX II SAE 5W-30	5W-30			X	
	TITAN CARGO MAXX II SAE10W-40	10W-40			X	
	TITAN CARGO UHPD SAE 15W-40	15W-40	X			2)
	TITAN UHPD SAE 15W-40	15W-40	X			2)
	TITAN UHPD SAE 10W-30	10W-30	X			
	PENTOTRUCK PRO SAE 15W-40	15W-40	X			2)
Gulf Oil International	Gulf Supreme Duty XLE	15W-40	X			2)
	Gulf Supreme Duty XLE	10W-30	X			
Hitachi Construction Machinery Co, Ltd.	Hitachi Genuine Engine Oil 10W-40 DH-2	10W-40	X			1)
Kuwait Petroleum	Q8 Formula Truck 7000 FE	10W-30	X			
	Q8 T 760	10W-30	X			1)
Liqui Moly GmbH	Liqui Moly Top Tec Truck 4650	10W-30	X			1)
	Liqui Moly Truck Nachfüll-Öl 10W-30	10W-30	X			1)
Lotos Oil	Turdus Powertec 1100	15W-40	X			1) 2)
Morris Lubricants	Versimax HD6	15W-40	X			1) 2)
MPM International Oil Company B.V.	Motor Oil 15W-40 Extra High Performance	15W-40	X			2)
Neste Markkinointi Oy Lubricants	Neste Turbo+ NEX 10W-40	10W-40	X			1)
Panolin AG	Panolin Universal LA-X	15W-40	X			1) 2)
						2)
Petro-Canada	Duron HP	15W-40	X			2)
	Duron HP	15W-40	X			2)
Petronas Lubricants, Italy	Petronas Urania 3000 LS	15W-40	X			1) 2)
Phillips 66 Lubricants	Guardol ECT 10W-30	10W-30	X			
	Guardol ECT 15W-40	15W-40	X			2)
	Kenndall Super-D XA 10W-30	10W-30	X			
	Kenndall Super-D XA 15W-40	15W-40	X			2)

TIN-ID: 000019003-012

Multi-grade oils – Category 2.1 (Low SAPS oils), SAE grades 0W-30, 10W-30, 5W-40, 10W-40 and 15W-40 for diesel engines

Manufacturer	Product/Brand name	SAE viscosity grade	TBN			Comments
			8 to 10 mgKOH/g	10 to 12 mgKOH/g	>12 mgKOH/g	
Repsol Lubricantes Y Especialidades, S.A.	Repsol Diesel Turbo THPD Mid Saps	15W-40	X			1) 2)
	REPSOL GIANT 7630 LS 15W-40	15W-40	X			2)
	REPSOL GIANT 7630 LS-FE 10W-30	10W-30	X			2)
Shell International Petroleum Company	Shell Fleet CK-4	10W-30	X			
	Shell Fleet CK-4	10W-40	X			
	Shell Fleet CK-4	15W-40	X			2)
	Shell Rimula Super	15W-40		X		1) 2)
	Shell Rimula RT4L	15W-40		X		1) 2)
	Shell Rotella T	15W-40		X		1) 2)
	Shell Rotella T3	15W-40		X		1) 2)
	Shell Rotella T3 Fleet	15W-40	X			2)
	Shell Rotella T5	10W-30	X			
	Shell Rotella T5	10W-40	X			1)
	Shell Rotella T6	5W-40		X		1)
	Shell Rimula K4	15W-40	X			2)
	Shell Rimula K6	15W-40	X			2)
	Shell Rimula K8	10W-30	X			
	Shell Rimula K8	10W-40	X			
	Shell Rimula R5 LE	10W-30	X			
	Shell Rimula R5 LE	10W-40	X			
	Shell Rotella T Triple Protection	15W-40		X		1)
	Shell Rotella T4 Triple Protection	15W-40	X			2)
	Shell Rimula R4 MV	15W-40	X			2)
Shell Rimula R4 L	15W-40	X				
Shell Sirius S4L	15W-40	X			2)	
SINOPEC Lubricant Co., Ltd.	Sinopec Tulux T700	15W-40	X			2)

TIN-ID: 000019003 - 012

Multi-grade oils – Category 2.1 (Low SAPS oils), SAE grades 0W-30, 10W-30, 5W-40, 10W-40 and 15W-40 for diesel engines

Manufacturer	Product/Brand name	SAE viscosity grade	TBN			Comments
			8 to 10 mgKOH/g	10 to 12 mgKOH/g	>12 mgKOH/g	
SRS Schmierstoff Vertrieb GmbH	SRS Turbo Rekord plus	15W-40	X			1) 2)
	SRS Turbo Rekord plus FE	10W-40	X			1)
	SRS Turbo Rekord ultra	15W-40	X			2)
	SRS Turbo Rekord ultra V	10W-30	X			
Sunoco Lubricants	Super C	15W-40		X		2)
	Super C Gold	15W-40		X		2)
	Super C Gold Elite	5W-40		X		
The United Oil Company	Duralene Dura-Max 15W-40	15W-40		X		2)
	Duralene Dura-Syn HD	5W-40		X		
TotalEnergies Lubrifiant	Caprano TDK 15W-40	15W-40		X		2)
	Caprano TDK FE 10W-30	10W-30	X			
	Rubia Optima 1100 15W-40	15W-40	X			2)
	Total Rubia Works 2000	10W-40	X			1)
	Total Rubia Works 4000	10W-40	X			1)
	Total Rubia Works 4000	15W-40	X			1) 2)
	Rubia Works 4000 10W-40	10W-40	X			
	Rubia Works 4000 15W-40	15W-40	X			2)
	Rubia Works 4000 FE 10W-30	10W-30	X			
	Total Star Max FE	10W-30	X			1)
	Total Rubia Works 2000 FE 10W-30	10W-30	X			1)
	Trinidad & Tobago National Petroleum Marketing Company Ltd. (NPMC)	Ultra Duty 15W-40 Engine Oil	15W-40	X		
Valvoline EMEA	All Fleet Extra LE SAE 15W-40	15W-40	X			1) 2)
	All-Fleet Extra LE NTI	15W-40	X			1) 2)
	All-Fleet Superior LE-X SAE 10W-40	10W-40	X			1)
	Valvoline All Fleet Superior LE	10W-30	X			1)
	Valvoline All Fleet Superior LE	15W-40	X			1) 2)
	Premium Blue 8100 15W-40	15W-40	X			2)

TIN-ID: 000019003-012

Multi-grade oils – Category 2.1 (Low SAPS oils), SAE grades 0W-30, 10W-30, 5W-40, 10W-40 and 15W-40 for diesel engines						
Manufacturer	Product/Brand name	SAE viscosity grade	TBN			Comments
			8 to 10 mgKOH/g	10 to 12 mgKOH/g	>12 mgKOH/g	
Valvoline LLC	Premium Blue 8600 ES	10W-30		X		1)
	Premium Blue 8600 ES	15W-40		X		1) 2)
Valvoline USA	All Fleet Plus	15W-40	X			1) 2)
Veedol International Limited	VEEDOL MAX-PRO SPECIAL LSP 15W-40	15W-40	X			1) 2)
Verco International	April Superpro RXL 1 Gold Plus	15W-40	X			1) 2)
Wolf Oil Corporation N.V.	Wolf Officialtech 15W40 MS	15W-40	X			2)
	Wolf Officialtech 15W40 MS Extra	15W-40	X			2)

Table 38:

6.6 Multi-grade oils – Category 3, SAE grades 5W-30, 5W-40, 10W-40 and 15W-40 for diesel engines

For details and special properties, see chapter “Lubricants for four-cycle engines” (→ Page 8).

Important

¹⁾ = No longer included in portfolio. Remaining stocks of this product can be used up as long as the shelf life has not expired.

Multi-grade oils

Multi-grade oils – Category 3, SAE grades 5W-30, 5W-40, 10W-40 and 15W-40 for diesel engines						
Manufacturer	Brand name	SAE viscosity grade	TBN			Comments
			8 to 10 mgKOH/g	10 to 12 mgKOH/g	>12 mgKOH/g	
Addinol Lube Oil GmbH	Addinol Commercial 1040 E4	10W-40		X		
	Addinol Ultra Truck MD 0538			X		
	Addinol Ultra Truck MD 0538	5W-30			X	
	Addinol Super Truck MD 1049	10W-40			X	
Aral AG	Aral Mega Turboral	10W-40			X	¹⁾
	Aral Mega Turboral 10W-40	10W-40			X	
	Aral Super Turboral	5W-30			X	¹⁾
	Aral Super Turboral 5W-30	5W-30			X	
Aramco Lubricants and Retail Company	Orizon HD vA	10W-40		X		
Atak Madeni Yağ Pas.San. Tic. Aş	Alpet Turbot FE	10W-40			X	¹⁾
	Alpet Turbot MMS	10W-40			X	¹⁾
Avia AG	Avia Turbosynth HT-E	10W-40			X	¹⁾
	Avia Turbosynth HT-U	5W-30			X	¹⁾
Avista Oil Deutschland GmbH	Avista pure EVO E4	10W-40			X	
	Avista pure EVO SWE	5W-30			X	
	Avista pure EVO SWE	10W-40			X	
Bahrain Petroleum Company B.S.C.	Frontier Turbo LDX	10W-40			X	¹⁾
BayWa AG	Tectrol Super Truck 530	5W-30			X	¹⁾
	Tectrol Super Truck 1040	10W-40			X	¹⁾
BP p.l.c.	BP Energol IC-MT 10W-40	10W-40			X	
	BP Vanellus Max	5W-30			X	¹⁾

T1W-ID: 000019006-012

Multi-grade oils – Category 3, SAE grades 5W-30, 5W-40, 10W-40 and 15W-40 for diesel engines						
Manufacturer	Brand name	SAE viscosity grade	TBN			Comments
			8 to 10 mgKOH/g	10 to 12 mgKOH/g	>12 mgKOH/g	
Castrol Ltd.	Castrol CRB Turbomax 10W-40 E4/E7	10W-40			X	
	Castrol Enduron MT	10W-40			X	¹⁾
	Castrol Enduron Plus	5W-30			X	¹⁾
	Castrol Elixion HD	5W-30			X	¹⁾
	Castrol Vecton 10W-40 E4/E7	10W-40			X	
	Castrol Vecton Long Drain	10W-40			X	
	Castrol Vecton Long Drain 5W-30 E4/E7	5W-30			X	
	Castrol Vecton Long Drain 10W-40 E7	10W-40			X	
	Castrol Vecton Long Drain 10W-40 E4/E7	10W-40			X	¹⁾
	Castrol Vecton 5W-30 Arctic	5W-30			X	¹⁾
	Castrol Vecton Fuel Saver 5W-30	5W-30			X	¹⁾
	Castrol Vecton Fuel Saver E7	5W-30			X	¹⁾
Cepsa	Cepsa Eurotrans SHPD	5W-30			X	¹⁾
	Cepsa Eurotrans SHPD	10W-40	X			¹⁾
Cepsa Comercial Petroleo Limited	Traction Advanced LD	10W-40			X	¹⁾
Champion Chemicals N.V.	Champion New Energy 10W40 Ultra	10W-40			X	
Chemicis Khavremianeh Kohan	Chemicis Excel Plus	10W-40			X	¹⁾
Chevron Lubricants (Caltex)	Delo Gold Ultra T SAE 10W-40	10W-40			X	
	Delo XLD Multigrade	10W-40			X	¹⁾
Chevron Lubricants (Texaco)	Ursa HD	10W-40			X	¹⁾
	Ursa Premium FE	5W-30			X	
	Ursa Super	10W-40	X			¹⁾
	Ursa Super TDX	10W-40			X	¹⁾
	Ursa TDX	10W-40			X	¹⁾
Deutsche Ölwerke Lubmin GmbH	AVENO HC PT Diesel	10W-40			X	
eni S.P.A.	eni i-Sigma top	10W-40			X	
	eni i-Sigma performance E4	10W-40			X	
Enoc Marketing LLC	Enoc Vulcan 770 SLD	10W-40	X			¹⁾
	Enoc Vulcan SLD	10W-40			X	¹⁾
Esso Deutschland GmbH	Mobil Delvac Modern 10W-40 Super Defense V1	10W-40			X	

TIN-ID: 000019506 - 012

Multi-grade oils – Category 3, SAE grades 5W-30, 5W-40, 10W-40 and 15W-40 for diesel engines

Manufacturer	Brand name	SAE viscosity grade	TBN			Comments
			8 to 10 mgKOH/g	10 to 12 mgKOH/g	>12 mgKOH/g	
Exxon Mobil Corporation	Mobil Delvac XHP Extra	10W-40			X	
	Mobil Delvac XHP Ultra 5W-30	5W-30			X	1)
	Mobil Delvac 1 5W-40	5W-40	X			
	Mobil Delvac 1 SHC	5W-40			X	1)
	Mobil Delvac 1 SHC 5W-40	5W-40			X	
	Mobil Delvac Ultra 5W-40 Ultimate Defense	5W-40			X	
	Mobil Delvac Ultra 5W-40 Ultimate Defense Mine	5W-40			X	
Exol Lubricants Ltd.	Taurus Extreme M3	10W-40			X	
Fabrika Maziva, FAM AD	Fenix Ultra Sint	10W-40			X	1)
Finke Mineralölwerk GmbH	AVIATICON Finko Truck LD	10W-40			X	
Fuchs Petrolub SE	Fuchs Titan Cargo SL	5W-30			X	1)
	Fuchs Titan Cargo MC	10W-40			X	1)
	Fuchs Max Way E4	10W-40				1)
	Fuchs Max Way Ultra	5W-30				1)
Fuchs Lubricants France S.A.	Cofran Marathon	10W-40			X	1)
Gulf Oil International	Gulf Fleet Force synth.	5W-30			X	
	Gulf Superfleet ELD	10W-40			X	
	Gulf Superfleet ULD	10W-40			X	
	Gulf Superfleet XLD	10W-40			X	
	Gulf Superfleet Synth ELD	10W-40			X	
High Industrial Lubricants & Liquids Corporation	Fastroil Force Ultra High Performance Diesel (UHPD)	10W-40			X	1)
INA MAZIVA Ltd.	INA Super E7 SAE 10W-40	10W-40			X	
Iranol Oil Co.	Iranol D40000-EIII	10W-40			X	1)
Kuwait Petroleum	Q8 T 860	10W-40		X		1)
	Q8 T 860 10W-40	10W-40			X	
	Q8 T 860 D	10W-40			X	1)
	Q8 T 860 S	10W-40			X	
	Q8 T 905	10W-40	X			1)
Lotos Oil	Turdus Powertec 3000	10W-40			X	1)
	Turdus Powertec Synthetic	5W-30			X	1)
LPC SA	CYCLON GRANIT SYN EURO FLEET 10W40	10W-40			X	1)

TIN-ID: 000019006 - 012

Multi-grade oils – Category 3, SAE grades 5W-30, 5W-40, 10W-40 and 15W-40 for diesel engines						
Manufacturer	Brand name	SAE viscosity grade	TBN			Comments
			8 to 10 mgKOH/g	10 to 12 mgKOH/g	>12 mgKOH/g	
Meguin	Megol Motorenöl Super LL Dimo Premium	10W-40			X	1)
MOL-LUB Ltd.	MOL Synt Diesel	10W-40		X		1)
	MOL Dynamic Synt Diesel E4 10W-40	10W-40			X	1)
Motorex AG	MC Power Plus SAE 10W/40	10W40			X	
Orlen Oil Sp.o.o.	Platinum Ultor Max	5W-30			X	1)
Panolin	Panolin Diesel HTE	10W-40			X	1)
Petrogal, S.A.	Galp Galaxia Extreme	5W-30		X		1)
	Galp Galaxia Ultra XHP	10W-40			X	1)
Petromin Oils Company	Petromin Turbo Master LD	10W-40			X	
Petronas Lubricants International	Urania 5000 10W-40				X	1)
	Urania 5000 F	5W-30			X	1)
PHI OIL GmbH	Motordor Silver 10W40	10W-40			X	1)
Raj Petro Specialities P Ltd.	Zoomol Rforce 8200 RF1	10W-40			X	1)
Ramoil S.p.A.	Duglas Oil Ultra HC 10W-40 UHPDO	10W-40			X	1)
Ravensberger Schmierstoff Vertrieb GmbH	RAVENOL Super Performance Truck	5W-30			X	1)
	RAVENOL Performance Truck	10W-40			X	1)
Repsol Lubricantes y Especialidades S.A.	REPSOL GIANT 9540 LL	10W-40			X	
	REPSOL GIANT 9550 FE-LL	5W-30			X	
	REPSOL GIANT 9530 LL	10W-40			X	
SCT Vertriebs GmbH	Fanfaro TRD E4 UHPD	10W-40		X		
	Mannol TS-6 UHPD Eco	10W-40		X		
	Pemco Diesel G-6 Eco UHPD	10W-40		X		
Shell International Petroleum Company	Shell Rimula R5 M	10W-40			X	
	Shell Rimula R6 M	10W-40			X	
	Shell Rimula R6 ME	5W-30			X	1)
	Shell Rimula R6 MS	10W-40			X	1)
	Shell Rimula Select R6	10W-40			X	
SK Lubricants Co.	ZIC X7000	5W-30			X	1)
SRS Schmierstoff Vertrieb GmbH	SRS Cargolub TFF	10W-40			X	1)
	SRS Cargolub TFL	5W-30			X	1)
	SRS Cargolub TFG	10W-40			X	
	SRS Cargolub TFG plus	10W-40			X	
	SRS Cargolub TFG ultra	10W-40			X	1)

TIN-ID: 000019006 - 012

Multi-grade oils – Category 3, SAE grades 5W-30, 5W-40, 10W-40 and 15W-40 for diesel engines						
Manufacturer	Brand name	SAE viscosity grade	TBN			Comments
			8 to 10 mgKOH/g	10 to 12 mgKOH/g	>12 mgKOH/g	
Tedex SA	Tedex Diesel Truck UHPD (S) Motor Oil	10W-40			X	¹⁾
TotalEnergies Lubrifiant	Cubalub ExtraDiesel	10W-40			X	¹⁾
	RUBIA TIR 8600 10W-40	10W-40			X	
	Total Rubia TIR 9200 FE	5W-30			X	¹⁾
Unil Opal	Unil Opal LCM 800	10W-40			X	¹⁾
Valvoline EMEA	Profleet	10W-40			X	¹⁾
	Valvoline ProFleet M SAE 10W-40	10W-40			X	
Wolf Oil Corporation N.V.	Wolf Vitaltech 10W40 Ultra	10W-40			X	¹⁾

Table 39:

6.7 Multi-grade oils – Category 3.1 (Low SAPS oils), SAE grades 5W-30, 10W-30 and 10W-40 for diesel engines

For details and special properties, see chapter “Lubricants for four-cycle engines” (→ Page 8).

Important

¹⁾ = No longer in portfolio. Remaining stocks of this product can be used up as long as the shelf life has not expired.

Multi-grade oils

Multi-grade oils – Category 3.1 (Low SAPS oils), SAE grades 5W-30, 10W-30 and 10W-40 for diesel engines						
Manufacturer	Brand name	SAE viscosity grade	TBN			Comments / Material number
			8 to 10 mgKOH/g	10 to 12 mgKOH/g	>12 mgKOH/g	
77 Lubricants	Engine Oil Special UHPD 10W-40	10W-40		X		
Addinol Lube Oil	Addinol Extra Truck MD 1049 LE	10W-40	X			¹⁾
Aral AG	Aral Mega Turboral LA	10W-40	X			
	Aral Super Turboral LA	5W-30	X			¹⁾
Atak Madeni Yağ Pas.San.Tic.Aş	Alpet Turbot MMS	10W-40		X		¹⁾
Avia AG	Avia Multi LSP Extra	10W-40		X		
Avista Oil Deutschland GmbH	Avista pure EVO GER	10W-40		X		
	Avista pure EVO CK-4	5W-30	X			
	Avista pure EVO CK-4	10W-30	X			
	Avista pure EVO CK-4	10W-40	X			
	Avista pure EVO PRIME 5W-30	5W-30		X		
BayWa AG	Tectrol Super Truck Plus XL 1040	10W-40	X			¹⁾
Belgin Madeni Yağlar	BELGIN LUBEX ROBUS MASTER LA 10W-40	10W-40		X		¹⁾
BP p.l.c.	BP Vanellus Max Eco 10W-40	10W-40			X	¹⁾
Castrol Ltd.	Castrol Vecton Long Drain 10W-30 E6/E9	10W-30	X			
	Castrol Vecton Long Drain 10W-40 E6/E9	10W-40	X			
	Castrol Vecton Fuel Saver 5W-30 E6/E9	5W-30	X			
Cepsa Comercial Petroleo, S.A.U.	Cepsa Eurotech LS 10W40 Plus	10W-40			X	¹⁾
	Traction Pro LS	10W-40			X	
Champion Chemicals N.V.	Champion OEM Specific 10W40 Ultra MS	10W-40		X		
	Champion OEM Specific 10W40 UHPD	10W-40			X	¹⁾
	Champion OEM Specific 10W40 UHPD Extra	10W-40		X		

TIN-ID: 000019019 - 014

Multi-grade oils – Category 3.1 (Low SAPS oils), SAE grades 5W-30, 10W-30 and 10W-40 for diesel engines

Manufacturer	Brand name	SAE viscosity grade	TBN			Comments / Material number
			8 to 10 mgKOH/g	10 to 12 mgKOH/g	>12 mgKOH/g	
Chevron Lubricants (Chevron)	Delo 400 RDE	10W-30		X		
	Delo 400 RDS	10W-40		X		
	Delo 400 XLE	15W-40	X			
	Delo 400 XLE HD	5W-30			X	
	Delo 400 XLE HD	10W-40			X	
	Delo 400 XLE SYN-HD	10W-40			X	
	Delo 400 XLE Synthetic	5W-30	X			1)
	Delo 400 LE Synthetic	5W-30	X			1)
	Delo 400 XSP	5W-30	X			
	Delo 400 XSP-SD	5W-30	X			
Chevron Lubricants (Texaco)	Ursa Ultra X	10W-30		X		1)
CONDAT Lubrifiants	Vicam Planet 10W40	10W-40			X	1)
Deutsche Ölwerke Lubmin GmbH	AVENO Universal UHPD	10W-40				1)
De Oliebron B.V.	Tor Turbosynth LSP Plus	10W-40			X	1)
Ellis Enterprices B.V.	Valvoline Profleet LA	5W-30	X			1)
	Profleet LA	5W-30	X			1)
eni S.p.a.	eni i-Sigma top MS	10W-40	X			1)
Enoc Marketing L.L.C.	Enoc Vulkan Green	10W-40			X	1)
Esso Deutschland GmbH	Mobil Delvac Modern 5W-30 Advanced Protection V3	5W-30	X			
	Mobil Delvac Modern 10W-40 Full Protection V4	10W-40		X		
Exol Lubricants Ltd.	Taurus Euro	10W-40		X		

Multi-grade oils – Category 3.1 (Low SAPS oils), SAE grades 5W-30, 10W-30 and 10W-40 for diesel engines						
Manufacturer	Brand name	SAE viscosity grade	TBN			Comments / Material number
			8 to 10 mgKOH/g	10 to 12 mgKOH/g	>12 mgKOH/g	
Exxon Mobil Corporation	Mobil Delvac 1 ESP	5W-30		X		
	Mobil Delvac 1 5W-30 Advanced Synthetic	5W-30		X		
	Mobil Delvac 1 LE	5W-30	X			
	Mobil Delvac 1 LE	5W-30			X	
	Mobil Delvac HD	10W-40		X		1)
	Mobil Delvac XHP ESP	10W-40			X	
	Mobil Delvac XHP ESP M	10W-40			X	1)
	Mobil Delvac XHP ESP S	10W-40			X	
	Mobil Delvac XHP ESP 10W-40 V2	10W-40		X		
	Mobil Delvac XHP LE	10W-40			X	55 gallons: 800141
	Mobil Delvac XHP Ultra LE	5W-30		X		
	Mobil Delvac Modern 10W-40 Advanced Protection	10W-40			X	
	Mobil Delvac Modern 10W-40 Extended Protection Plus	10W-40			X	
	Finke Mineralölwerk GmbH	AVIATICON Finko Super Truck LA Plus	10W-40		X	
AVIATICON Premium Truck LA Plus 5W-30		5W-30		X		
Fuchs Lubricants Germany GmbH	Titan Cargo FELX LD 10W-40	10W-40		X		
Fuchs Petrolub SE	Titan Cargo Maxx	5W-30			X	
	Titan Cargo Maxx II	5W-30			X	
	Titan Cargo Maxx	10W-40			X	Enhanced corrosion protection
	Titan Cargo Maxx II	10W-40			X	
	Fuchs Titan Cargo EU6	5W-30	X			1)
	Fuchs Titan Cargo LA	5W-30	X			1)
	Fuchs Titan Cargo LA	10W-40		X		
	Fuchs Titan Cargo LA	10W-40	X			
	PENTOTRUCK ULTRA SAE 10W-30	10W-30	X			

TIM-ID: 000019019 - 014

Multi-grade oils – Category 3.1 (Low SAPS oils), SAE grades 5W-30, 10W-30 and 10W-40 for diesel engines

Manufacturer	Brand name	SAE viscosity grade	TBN			Comments / Material number
			8 to 10 mgKOH/g	10 to 12 mgKOH/g	>12 mgKOH/g	
Gulf Oil International	Gulf Superfleet ULE	10W-40	X			Enhanced corrosion protection
	Gulf Superfleet Synth ULE	5W-30	X			
	Gulf Superfleet XLE	10W-30	X			
	Gulf Superfleet XLE	10W-40	X			
	Gulf Superfleet XLE Plus	10W-40	X			
	Gulf Superfleet Synth XLE	10W-30		X		
	Gulf Superfleet Synth XLE	10W-40	X			1)
	Gulf Superfleet Universal	5W-30			X	
	Gulf Superfleet Universal	10W-40			X	
Helios Lubeoil	Helios Premium KMXX 10W-40	10W-40	X			1)
Huiles Berliet S.A.	RTO Extensia FP	10W-40	X			1)
Igol	PRO 200 X	10W-40	X			1)
IINA Maziva d.o.o.	INA Super 2009 5W-30	5W-30	X			
Kuwait Petroleum Research & Technology	Q8 T 905	10W-40	X			1)
	Q8 T 904	10W-40		X		
	Q8 T 904 FE	10W-30	X			1)
	Q8 T 905	10W-40	X			
	Q8 T 910	5W-30	X			1)
	Q8 Formula Truck 8500	10W-40	X			1)
	Q8 Formula Truck 8500 FE	10W-30	X			1)
	Q8 Formula Truck 8700 FE	5W-30	X			
	Q8 Formula Truck 8900 FE 5W-30	5W-30			X	
LLK Finland Oy	Teboil Super XLD-2	5W-30			X	1)
LPC	Cyclon Granit Syn Euro Maxx 10W-40	10W-40	X			1)
Meguin GmbH & Co. KG	megol Motorenoel Low SAPS	10W-40		X		1)
	megol Motorenoel Low SAPS	10W-40	X			1)
MOL-LUB Ltd.	MOL Dynamic Mistral XT 5W-30	5W-30	X			
	MOL Dynamic Mistral 10W-40	10W-40	X			1)
Morris Lubricants	Ring Free Ultra	10W-40		X		1)
	Fendt Power Grade 10W-40	10W-40		X		1)
	Versimax HD8	10W-40	X			1)

TBM-ID: 0000019019-014

Multi-grade oils – Category 3.1 (Low SAPS oils), SAE grades 5W-30, 10W-30 and 10W-40 for diesel engines						
Manufacturer	Brand name	SAE viscosity grade	TBN			Comments / Material number
			8 to 10 mgKOH/g	10 to 12 mgKOH/g	>12 mgKOH/g	
Motorex AG	Motorex Focus QTM	10W40	X			1)
	Motorex / York Focus QTM	10W40	X			
	Motorex York Nexus FE SAE 5W-30	5W30			X	1)
	Motorex Nexus FE SAE 5W-30	5W30	X			
MPM International Oil Company B.V.	Motor Oil 10w-40 Premium Synthetic Ultra High Performance Diesel	10W-40		X		
Neste Markkinointi Oy Lubricants	Neste Turbo+ LSA 5W-30	5W-30	X			1)
North Sea Lubricants	Tidal Power Special UHPD 10W-40	10W-40		X		
Oel-Brack AG	Midland maxtra	10W-40		X		
OMV Petrol Ofisi A.Ş	Maximus HD-E	5W-30	X			
Orlen Oil	Platinum Ultor Complete	10W-40	X			
	Platinum Ultor Optimo	10W-30	X			1)
	Platinum Ultor Progress	10W-40		X		1)
	Mogul Diesel L-SAPS	10W-40		X		1)
Oscar Lubricants LLC	Oscar Zircon Novus	10W-40	X			1)
Panolin	Panolin Diesel Synth EU-4	10W-40	X			1)
	Panolin Ecomot	5W-30		X		1)
	Panolin Ecomot	10W-30	X			1)
	Panolin Ecomot	10W-40	X			1)
Petro-Canada Lubricants Inc.	Duron SHP E6	10W-40		X		
	Duron UHP 5W30	5W-30	X			
	Duron UHP E6	5W-30			X	
	Duron UHP E6	10W-40			X	
	Duron UHP E6 10W40	10W-40	X			
Petrogal, S.A.	Galp Galaxia Ultra LS	10W-40	X			1)
Petrolube Lubricants	Euromax	10W-40		X		1)
Petronas Lubricants International	Petronas Urania 5000 E	5W-30			X	1)
	Petronas Urania 5000 E	10W-40			X	1)
	Petronas Urania 5000 LS-FX	5W-30		X		1)
	Petronas Urania 5000 LSF 5W-30	5W-30	X			1)
	Petronas Urania 5000 LS 10W-40	10W-40	X			1)
	Petronas Urania FE LS	5W-30			X	1)
PHI OIL GmbH	Motodor LSP Gold 5W30	5W-30			X	1)
	Motodor LSP Silver	10W-40		X		1)

TIN-ID: 000019019 - 014

Multi-grade oils – Category 3.1 (Low SAPS oils), SAE grades 5W-30, 10W-30 and 10W-40 for diesel engines

Manufacturer	Brand name	SAE viscosity grade	TBN			Comments / Material number
			8 to 10 mgKOH/g	10 to 12 mgKOH/g	>12 mgKOH/g	
Prista Oil Ad	Prista UHPD	10W-40	X			1)
Ravensberger Schmierölvertrieb GmbH	Ravenol Euro VI Truck	10W-40	X			1)
	Ravenol Euro VI Truck SAE 10W-40	10W-40		X		1)
Repsol Lubricantes y Especialidades, S.A.	REPSOL GIANT 9630 LS-LL	10W-40	X			
	REPSOL GIANT 9660 LS-FE-LL 5W-30	5W-30			X	
	Repsol DieselTurbo VHPD Mid SAPS	5W-30		X		
Rowe Mineralölwerk GmbH	Rowe Hightec Truckstar SAE 10W-40 HC-LA	10W-40		X		
Shell International Petroleum Company	Shell Fleet Pro CK-4	5W-30		X		1)
	Shell Fleet Pro CK-4	10W-40			X	
	Shell Rimula K10	10W-40			X	Enhanced corrosion protection
	Shell Rimula K15	5W-30		X		
	Shell Rimula R6 LM	10W-40		X		1) Enhanced corrosion protection
	Shell Rimula R6 LME	5W-30		X		
	Shell Rimula R6 LME Plus	5W-30		X		
	Shell Rimula R6 ME Extra	5W-30			X	
	Shell Rimula Ultra	5W-30			X	
	Shell Sirius S6 LM	10W-40			X	
SINOPEC Lubricant Co., Ltd.	SINOPEC TULUX T700 Plus	10W-40		X		
SRS Schmierstoff Vertrieb GmbH	SRS Antikorrol MLA	10W-40		X		1) Enhanced corrosion protection
	SRS Cargolub TLA	10W-40	X			1)
	SRS Cargolub TLA plus	10W-40		X		
	SRS Cargolub TLS	5W-30			X	1)
	SRS Cargolub TLS plus	5W-30		X		
	SRS Cargolub TLS top	5W-30	X			
	SRS Turbo Diesel LA	10W-40	X			1)
	SRS Cargolub Leichtlauf- Motorenöl LA	10W-40		X		
	SRS Turbo-Rekord top FE	10W-40		X		
SRS Turbo-Rekord ultra FE	10W-40	X				

TIN-ID: 000019019-014

Multi-grade oils – Category 3.1 (Low SAPS oils), SAE grades 5W-30, 10W-30 and 10W-40 for diesel engines						
Manufacturer	Brand name	SAE viscosity grade	TBN			Comments / Material number
			8 to 10 mgKOH/g	10 to 12 mgKOH/g	>12 mgKOH/g	
TotalEnergies Lubrifiant	Rubia Optima 3100 10W-40	10W-40		X		
	Rubia Works 3000 FE 5W-30	5W-30			X	
	Rubia Works 5000 FE 5W-30	5W-30			X	
	Rubia Works 5000 FE 10W-30	10W-30		X		
	Rubia Works 5000 10W-40	10W-40		X		
	Star Max Gen 6 FE 10W-30	10W-30		X		
	Total Rubia TIR 8900	10W-40	X			1)
	Total Rubia Works 2500	10W-40	X			1)
	Total Rubia Works 3000	10W-40		X		1)
	Total Rubia Works 3000 FE	5W-30			X	1)
Transnational Blenders B.V.	Engine Oil Special Synthetic UHPD 10W-40	10W-40		X		
Valvoline EMEA	Valvoline ProFleet LS	5W-30			X	1)
	Valvoline ProFleet LS	10W-40	X			1)
	ProFleet LS NTI	10W-40	X			1)
Veedol International Limited	VEEDOL MARATRON EXTRA LSP 10W-40	10W-40		X		1)
Wibo Schmierstoffe GmbH	Wibokraft Ultra AF 10W40	10W-40		X		1)
Wolf Oil Corporation N.V.	Champion OEM Specific 10W-40 UHPD MS	10W-40		X		
	Champion OEM Specific 10W-40 UHPD S	10W-40		X		
	Wolf Officialtech 10W40 Ultra MS	10W-40		X		
	Wolf Officialtech 10W40 UHPD	10W-40			X	1)
	Wolf Officialtech 10W40 UHPD Extra	10W-40		X		
	Wolf Officialtech 10W40 UHPD MS	10W-40		X		
	Wolf Officialtech 10W40 UHPD S	10W-40		X		

Table 40:

TIM-ID: 000019019 - 014

6.8 Lubricating Greases

6.8.1 Lubricating greases for general applications

For details and special features, see chapter "Lubricating greases" (→ Page 17)

Manufacturer	Brand name	Notes
Aral AG	Mehrzweckfett Arallub HL2	
BP p.l.c.	Energrease LS2	
Castrol Ltd.	Spheerol AP2	
Chevron	Multifak EP2	
SRS Schmierstoff Vertrieb GmbH	SRS Wiolub LFK2	
Shell Deutschland GmbH	Shell Gadus S2 V220 2	
Total	Total Multis EP2	
Veedol International	Multipurpose	

Table 41:

6.8.2 Lubricating greases for diesel engine-generator set components

Important		
Mixtures of different greases are not permitted!		
Manufacturer	Brand name	Notes
Exxon Mobil Corporation	Mobil Polyrex EM	High-temperature grease: Lubricity in the range from -30 to 250 °C (-22 to 482 °F) For: <ul style="list-style-type: none"> • Generator bearings of Marathon generators • Generator bearings of Leroy-Somer generators^{*)} • Fan wheel and belt pulley bearing on electrically driven coolant cooler, Series 4000
Shell	GADUS S3 V220C	For generator bearings of Leroy-Somer generators ^{*)}
SKF	Mehrzweckfett LGMT2	For generator bearings of HM generators
ROCOL Limited	Rocol RTD-Compound	For belt tensioner on electrically driven coolant cooler, Series 4000
ASCO Power Technologies	Lubrication Kit 75-100	For automatic transfer switch (ATS) ASCO

^{*)} NOTE: For information about the applicable lubricating greases for Leroy-Somer generators, refer to the nameplate on the generator.

For information about lubricating greases for generators made by other manufacturers, please contact the service partners.

7 Approved Coolants

7.1 Series-based usability of coolant additives

All details are based on the coolant circuit on the engine side, no allowance is made for external add-on components.

For details and special properties, see “General information” (→ Page 25) and “Unsuitable materials in the coolant circuit” (→ Page 25) in the chapter “Coolants”.

Important

In the case of an engine coolant circuit with no light metal elements but with external add-on components containing light metal (e.g. cooling system or preheater), the coolant approvals for cooling systems containing light metal shall apply. If you have any doubts about a coolant application, consult your contact person at Rolls-Royce Solutions.

Any deviant special agreements between the customer and Rolls-Royce Solutions remain valid.

Series	Cooling system containing light metals	Coolant without antifreeze
2000Gx5 2000Gx6	Yes	<ul style="list-style-type: none"> • Concentrates for cooling systems containing light metal, see (→ Page 125) • Ready mixtures for cooling systems containing light metal, see (→ Page 126)
4000Gx3 4000Gx4 4000Gx5	No	<ul style="list-style-type: none"> • Concentrates for cooling systems containing light metal, see (→ Page 127) • Ready mixtures for cooling systems containing light metal, see (→ Page 129)

Series	Cooling system containing light metals	Antifreeze	
2000Gx5 2000Gx6	Yes	<ul style="list-style-type: none"> • Concentrates for cooling systems containing light metal, see (→ Page 130) • Ready mixtures for cooling systems containing light metal, see (→ Page 133) 	<ul style="list-style-type: none"> • Concentrates based on ethylene glycol (suitable for series with and without light metal), see (→ Page 145)
4000Gx3 4000Gx4 4000Gx5	No	<ul style="list-style-type: none"> • Concentrates for cooling systems containing light metal, see (→ Page 138) • Ready mixtures for cooling systems containing light metal, see (→ Page 141) 	<ul style="list-style-type: none"> • Concentrates based on ethylene glycol (suitable for series with and without light metal), see (→ Page 145) • Ready mixture based on propylene glycol for series not containing light metal, see (→ Page 147)

Series	Cooling system containing light metals	Antifreeze for intercoolers (TB)
2000Gx6 with optional inter-cooler (TB)	Yes	<ul style="list-style-type: none"> • Concentrates for cooling systems containing light metal, see (→ Page 136) • Ready mixtures for cooling systems containing light metal (50/50 mixes), see (→ Page 136)

TUM-ID: 0000063206 - 010

7.2 Coolants without antifreeze for cooling systems containing light metal

7.2.1 Coolant without antifreeze – Concentrates for cooling systems containing light metal

For details and special properties, see chapter “Coolants” (→ Page 19).

Important
For Series 1163-03 and 1163-04 marine engines, only coolants marked with an asterisk * in the product/brand name may be used.

Coolants without antifreeze – concentrates

Manufacturer	Product/Brand name	Inhibitors							Runtime Hours/Years	Comments/ Material number
		Organic	Silicon	Nitrite	Phosphate	Molybdate	Borates	2-EHS		
Rolls-Royce Solutions GmbH	Coolant CS100 Corrosion Inhibitor Concentrate*		X					X	6000 / 2	No longer included in portfolio. Remaining stocks of this product can be used up as long as the shelf life has not expired.
Rolls-Royce Solutions America Inc.	Power Cool® Plus 6000 Concentrate*		X					X	6000 / 2	Colored green 23533526 (1 gallon) 23533527 (5 gallons) Available from Rolls-Royce Solutions America Inc.
BASF SE	Glyscorr G93 green*		X					X	6000 / 2	X00054105 (barrel) X00058062 (canister)
CCI Corporation	A 216		X			X			6000 / 2	
CCI Manufacturing IL Corporation	A 216		X			X			6000 / 2	X00051509 (208 l)
Detroit Diesel Corp.	Power Cool Plus 6000		X			X			6000 / 2	Colored red
Drew Marine	Drewgard XTA*		X					X	6000 / 2	
ExxonMobil	Mobil Delvac Extended Life Corrosion Inhibitor		X			X			6000 / 2	
Old World Industries Inc.	Final Charge Extended Life Corrosion Inhibitor (A 216)		X			X			6000 / 2	
Valvoline	ZEREX G-93*		X					X	6000 / 2	
	OEM Advanced 93*		X					X	6000 / 2	
YORK SAS	York 719*		X					X	6000 / 2	

7.2.2 Coolant without antifreeze – Ready mixtures for cooling systems containing light metal

For details and special properties, see chapter “Coolants” (→ Page 19).

Important

For Series 1163-03 and 1163-04 marine engines, only coolants marked with an asterisk * in the product name may be used.

Coolant without antifreeze, ready mixtures

Manufacturer	Product name	Inhibitors							Runtime Hours/Years	Comments/ Material number
		Organic	Silicon	Nitrite	Phosphate	Molybdate	Borates	2-EHS		
Rolls-Royce Solutions GmbH	Coolant CS10/90 Corrosion Inhibitor Premix*		X					X	6000 / 2	No longer included in portfolio. Remaining stocks of this product can be used up as long as the shelf life has not expired.

7.3 Coolants without antifreeze for cooling systems free of light metal

7.3.1 Coolants without antifreeze – Concentrates for cooling systems not containing light metal

For details and special properties, see chapter “Coolants” (→ Page 19).

Coolants without antifreeze – concentrates

Manufacturer	Product/Brand name	Inhibitors						Runtime Hours/Years	Comments/ Material number	
		Organic	Silicon	Nitrite	Phosphate	Molybdate	Borates			2-EHS
Rolls-Royce Solutions GmbH	Coolant CS100 Corrosion Inhibitor Concentrate		X					X	6000 / 2	No longer included in portfolio. Remaining stocks of this product can be used up as long as the shelf life has not expired.
Rolls-Royce Solutions America Inc.	Power Cool® Plus 6000 Concentrate		X					X	6000 / 2	Colored green 23533526 (1 gallon) 23533527 (5 gallons) Available from Rolls-Royce Solutions America Inc.
Arteco NV	Havoline XLI	X						X	6000 / 2	
BASF SE	Glyscorr G93 green		X					X	6000 / 2	X00054105 (barrel) X00058062 (canister)
CCI Corporation	A 216	X				X			6000 / 2	
CCI Manufacturing IL Corporation	A 216	X				X			6000 / 2	X00051509 (208 l)
Chevron	Delo XLI Corrosion Inhibitor - Concentrate	X						X	6000 / 2	
Chiron Chemicals Pty Ltd	PrixMax RCP	X						X	6000 / 2	
Detroit Diesel Corp.	Power Cool Plus 6000	X				X			6000 / 2	Colored red
Drew Marine	Drewgard XTA		X					X	6000 / 2	
ExxonMobil	Mobil Delvac Extended Life Corrosion Inhibitor	X				X			6000 / 2	
ImproChem	COOL-18		X	X				X	6000 / 2	
Nalco Water An Eco-lab Company	Alfloc™ 3477	X						X	6000 / 2	
	Nalcool® 2000		X	X				X	6000 / 2	

TIM-ID: 00001946-014

Manufacturer	Product/Brand name	Inhibitors							Runtime Hours/Years	Comments/ Material number
		Organic	Silicon	Nitrite	Phosphate	Molybdate	Borates	2-EHS		
Old World Industries Inc.	Final Charge Extended Life Corrosion Inhibitor (A 216)	X				X			6000 / 2	
Total Lubrifiants	Total WT Supra	X						X	6000 / 2	
Valvoline	Zerex G-93		X					X	6000 / 2	
	OEM Advanced 93		X					X	6000 / 2	
YORK SAS	York 719		X					X	6000 / 2	

7.3.2 Coolant without antifreeze – Ready mixtures for cooling systems not containing light metal

For details and special properties, see chapter on “Coolants” (→ Page 19)

Coolant without antifreeze, ready mixtures

Manufacturer	Product/Brand name	Inhibitors						Runtime Hours/Years	Comments/ Material number	
		Organic	Silicon	Nitrite	Phosphate	Molybdate	Borates			2-EHS
Rolls-Royce Solutions GmbH	Coolant CS 10/90 Corrosion Inhibitor Premix		X					X	6000 / 2	No longer included in portfolio. Remaining stocks of this product can be used up as long as the shelf life has not expired.
Chiron Chemicals Pty Ltd	PrixMax RCP Premix (8 %)	X						X	6000 / 2	
Nalco Water An Eco-lab Company	Alfloc™ 3443 (7%)	X						X	6000 / 2	

7.4 Antifreezes for cooling systems containing light metal

7.4.1 Antifreeze – Concentrates for cooling systems containing light metal

For details and special properties, see chapter “Coolants” (→ Page 19).

Antifreeze, concentrates

Manufacturer	Product/Brand name	Inhibitors						Runtime Hours/Years	Comments/ Material number	
		Organic	Silicon	Nitrite	Phosphate	Molybdate	Borates			2-EHS
Rolls-Royce Solutions GmbH	Coolant AO 100 Antifreeze Concentrate	X						9000 / 3	No longer included in portfolio. Remaining stocks of this product can be used up as long as the shelf life has not expired.	
	Coolant AH 100 Antifreeze Concentrate	X	X				X	X	9000 / 5	No longer included in portfolio. Remaining stocks of this product can be used up as long as the shelf life has not expired.
Alliance Automotive Service GmbH	NAPA Premium Kühlerschutz N48	X	X				X	X	9000 / 5	
Avia AG	Antifreeze APN - S	X							9000 / 3	
BASF SE	Glysantin G05		X	X			X		9000 / 5	
	Glysantin G48 blue green	X	X				X	X	9000 / 5	X00058054 (25 l) X00058053 (210 l)
	Glysantin G30 pink	X							9000 / 3	X00058072 (canister) X00058071 (barrel)
	Glysantin G30 ECO pink BMB 100	X							9000 / 3	
BayWa AG	Tectrol Coolprotect	X	X				X	X	9000 / 5	
Castrol	Castrol Radicool NF	X	X				X	X	9000 / 5	
CCI Corporation	L 415	X				X			9000 / 3	
COPARTS Autoteile GmbH	CAR 1 Premium Longlife Kühlerschutz C48	X	X				X	X	9000 / 5	
Daimler Trucks North America	Alliance OAT Extended Life Coolant	X				X			9000 / 3	
Detroit Diesel Corp.	Power Cool Plus Coolant	X				X			9000 / 3	
	Power Cool Diesel Engine Coolant		X	X					9000 / 3	
Drew Marine	Drewgard ZX	X							9000 / 3	

TUM-ID: 000019149-014

Manufacturer	Product/Brand name	Inhibitors						Runtime Hours/Years	Comments/ Material number
		Organic	Silicon	Nitrite	Phosphate	Molybdate	Borates		
ExxonMobil	Mobil Delvac Extended Life Coolant	X				X		9000 / 3	
	Mobil Heavy Duty Coolant		X	X				9000 / 3	
	Mobil Mining Coolant		X	X				9000 / 3	
Finke Mineralölwerk GmbH	AVIATICON Finkofreeze F30	X						9000 / 3	
	AVIATICON Finkofreeze F48	X	X			X	X	9000 / 5	
Fuchs SE	Maintain Fricofin	X	X			X	X	9000 / 5	
	Maintain Fricofin G12 Plus	X						9000 / 3	X00058074 (canister) X00058073 (barrel)
	Titan Fricofin	X	X			X	X	9000 / 5	
	Titan Fricofin G12 Plus	X						9000 / 3	
Krafft S.L.U.	Refrigerante ACU 2300		X	X		X		9000 / 3	X00058075 (barrel)
LAEMMLE Chemicals AG	ROXOR ANTI-FROST MT-325	X	X			X	X	9000 / 5	
Mitan Mineralöl GmbH	Alpine C30	X						9000 / 3	
	Alpine C48	X	X			X	X	9000 / 5	
MJL Bangladesht Ltd.	Omera Premium Coolant	X						9000 / 3	
MOFIN Deutschland GmbH & Co KG	MOFIN Kühlerschutz M48 Premium Protect	X	X			X	X	9000 / 5	
Moove Lubricants Limited	Mobil Antifreeze Extra	X	X			X	X	9000 / 5	
Nalco Water An Eco-lab Company	Nalcool NF 48 C	X	X			X	X	9000 / 5	
Navistar Inc.	Fleetrite Nitrite-Free Extended Life Coolant	X				X		9000 / 3	
Old World Industries Inc.	Blue Mountain Heavy Duty Extended Life Coolant	X				X		9000 / 3	
	Fleet Charge SCA Pre-charged Coolant / Antifreeze		X	X				9000 / 3	
	Final Charge Global Extended Life Coolant Antifreeze	X				X		9000 / 3	
	Peak Heavy Duty Coolant		X	X				9000 / 3	
Penske Power Systems	Power Cool - HB500 Coolant Concentrate	X	X			X		9000 / 3	
Raloy Lubricantes	Antifreeze Long Life NF-300 Concentrate	X	X			X	X	9000 / 5	

TIM-ID: 000001949-014

Manufacturer	Product/Brand name	Inhibitors						Runtime Hours/Years	Comments/ Material number
		Organic	Silicon	Nitrite	Phosphate	Molybdate	Borates		
Recochem Inc.	HD Expert™ Endurance	X				X		9000 / 3	
	R542	X	X				X	9000 / 3	
Total Lubrifiants	Glacelf MDX	X	X				X X	9000 / 5	
Valvoline	Zerex G-05		X	X			X	9000 / 5	
	Zerex G-48	X	X				X X	9000 / 5	
	Zerex G-30	X						9000 / 3	
	OEM Advanced 05		X	X			X	9000 / 5	
	OEM Advanced 30	X						9000 / 3	
	OEM Advanced 48	X	X				X X	9000 / 5	
Volvo Trucks	Road Choice Nitrite-Free OAT Extended Life Coolant	X				X		9000 / 3	

Table 42:

7.4.2 Antifreeze – Ready mixtures for cooling systems containing light metals

For details and special properties, see chapter “Coolants” (→ Page 19).

Important

For model type 00 to 07 Series 2000 marine engines, only coolants marked with an asterisk * in the product/brand name may be used.

Ready mixtures for cooling systems containing light metals

Manufacturer	Product/Brand name	Inhibitors							Runtime Hours/Years	Comments/ Material number
		Organic	Silicon	Nitrite	Phosphate	Molybdate	Borates	2-EHS		
Rolls-Royce Solutions GmbH	Coolant AH 35/65 Anti-freeze Premix*	X	X				X	X	9000 / 5	No longer included in portfolio. Remaining stocks of this product can be used up as long as the shelf life has not expired.
	Coolant AH 40/60 Anti-freeze Premix*	X	X				X	X	9000 / 5	No longer included in portfolio. Remaining stocks of this product can be used up as long as the shelf life has not expired.
	Coolant AH 50/50 Anti-freeze Premix	X	X				X	X	9000 / 5	No longer included in portfolio. Remaining stocks of this product can be used up as long as the shelf life has not expired.
Rolls-Royce Solutions America Inc.	Power Cool® Universal 35/65 mix*	X	X				X	X	9000 / 5	800085 (5 gallons) 800086 (55 gallons)
	Power Cool® Universal 50/50 mix	X	X				X	X	9000 / 5	800071 (5 gallons) 800084 (55 gallons)
	Power Cool® Off-Highway Coolant 50/50 Premix		X	X			X		9000 / 5	23533531 (5 gallons) 23533532 (55 gallons)
A. Roth GmbH & Co KG	CRO Coolant Plus -25 °C Ready*	X							9000 / 3	
BayWa AG	Tectrol Coolprotect Mix 3000*	X							9000 / 3	Antifreeze protection down to -24 °C
BASF SE	Glysantin G30 RM/50 ECO pink BMB 100	X							9000 / 3	
Castrol	Castrol Radicool NF Premix (45%)	X	X				X	X	9000 / 5	

Manufacturer	Product/Brand name	Inhibitors						Runtime Hours/Years	Comments/ Material number
		Organic	Silicon	Nitrite	Phosphate	Molybdate	Borates		
CCI Corporation	L 415 (50%)	X				X		9000 / 3	
Cepca Comercial Petróleo S.A.U.	XTAR Super Coolant Hybrid NF 50%	X	X				X	X	9000 / 5
Daimler Trucks North America	Alliance 50/50 Prediluted OAT Extended Life Coolant	X				X			9000 / 3
Detroit Diesel Corp.	Power Cool Plus Prediluted Coolant (50/50)	X				X			9000 / 3
	Power Cool Prediluted 50/50 Diesel Engine Coolant		X	X					9000 / 3
Exxon Mobil	Mobil Delvac Extended Life Prediluted Coolant (50/50)	X				X			9000 / 3
	Mobile Heavy Duty 50/50 Prediluted Coolant		X	X					9000 / 3
	Mobile Mining 50/50 Prediluted Coolant		X	X					9000 / 3
Fast Chemical SRL	Fast Coolant G30 50%	X							9000 / 3
Finke Mineralölwerk GmbH	AVIATICON Finkofreeze F48 RM 50/50	X	X				X	X	9000 / 5
	AVIATICON Finkofreeze F30 RM 40:60 +*	X							9000 / 3
Fuchs SE	Maintain Fricofin 50 (Ready Mix)	X	X				X	X	9000 / 5
	Titan Fricifin 50	X	X				X	X	9000 / 5
Moove Lubricants Limited	Mobil Coolant Extra Ready -36 °C	X	X				X	X	9000 / 5
Navistar Inc.	Fleetrite 50/50 Prediluted Nitrite-Free Life Coolant	X				X			9000 / 3
Old World Industries Inc.	Blue Mountain Heavy Duty Extended Life Prediluted Coolant (50/50)	X				X			9000 / 3
	Final Charge Global Extended Life Prediluted Coolant/Antifreeze (50/50)	X				X			9000 / 3
	Fleet Charge SCA Pre-charged 50/50 Prediluted Coolant		X	X					9000 / 3
Penske Power Systems	Power Cool - HB500 Pre-mix 35/65*	X	X				X		9000 / 3
	Power Cool - HB500 Pre-mix 50/50	X	X				X		9000 / 3

TMM-ID: 0000019156 - 012

Manufacturer	Product/Brand name	Inhibitors						Runtime Hours/Years	Comments/ Material number	
		Organic	Silicon	Nitrite	Phosphate	Molybdate	Borates			2-EHS
Raloy Lubricantes	Antifreez Long Life NF-300 Ready-to-Use (50:50)	X	X				X	X	9000 / 5	
Recochem	HD Expert™ Endurance 50-50 Prediluted	X				X			9000 / 3	
	R 542 35/65*	X	X				X		9000 / 3	
Total Lubrificants	Coollef MDX -26 °C*	X	X				X	X	9000 / 5	
	Coollef MDX -37 °C	X	X				X	X	9000 / 5	
Valvoline	Zerex G-05 50/50 Mix		X	X			X		9000 / 5	
	Zerex G-48 premix 50%	X	X				X	X	9000 / 5	
	OEM Advanced 48 pre-mix 50%	X	X				X	X	9000 / 5	
Volvo Trucks	Road Choice 50/50 Pre-diluted Nitrite-Free OAT Extended Life Coolant	X				X			9000 / 3	
YPF S.A. Argentina	Kriox MTL50	X				X			9000 / 3	

Table 43:

7.4.3 Antifreeze – Approved coolants for Series 2000Gx6 with intercooler option (TB)

For more information, details and special properties, see chapter “Coolants” (→ Page 19)

The external intercooler (TB) is an a water/air charge-air cooler. Concentrates or ready mixtures for use in the charge-air coolant circuit (LT circuit) are described in the following two tables of this chapter.

They must meet the following requirements:

- Antifreeze
- For cooling systems containing light metal
- Silicon-free
- For ready mixtures: 50% by volume application concentration.

Antifreeze – Concentrates for Series 2000Gx6 with intercooler option (TB)

Manufacturer	Product/Brand name	Inhibitors					Runtime Hours/Years	Comments/ Material number
		Organic	Silicon	Nitrite	Phosphate	Molybdate		
Rolls-Royce Solutions GmbH	Coolant AO 100 Antifreeze Concentrate	X					9,000 / 3	Remaining stocks of this product can be used up as long as the shelf life has not expired.
Avia AG	Antifreeze APN - S	X					9,000 / 3	
BASF SE	Glystantin G30 pink	X					9,000 / 3	X00058072 (canister) X00058071 (barrel)
	Glystantin G30 ECO pink BMB 100	X					9,000 / 3	
CCI Corporation	L 415	X				X	9,000 / 3	
Daimler Trucks North America	Alliance OAT Extended Life Coolant	X				X	9,000 / 3	
Detroit Diesel Corp.	Power Cool Plus Coolant	X				X	9,000 / 3	
Drew Marine	Drewgard ZX	X					9,000 / 3	
ExxonMobil	Mobil Delvac Extended Life Coolant	X				X	9,000 / 3	
Finke Mineralölwerk GmbH	AVIATICON Finkofreeze F30	X					9,000 / 3	
Fuchs SE	Maintain Fricofin G12 Plus	X					9,000 / 3	X00058074 (canister) X00058073 (barrel)
	Titan Fricofin G12 Plus	X					9,000 / 3	
Mitan Mineralöl GmbH	Alpine C30	X					9,000 / 3	
MJL Bangladesh Ltd.	Omera Premium Coolant	X					9,000 / 3	
Navistar Inc.	Fleetrite Nitrite-Free Extended Life Coolant	X				X	9,000 / 3	
Old World Industries Inc.	Blue Mountain Heavy Duty Extended Life Coolant	X				X	9,000 / 3	
	Final Charge Global Extended Life Coolant Antifreeze	X				X	9,000 / 3	
Recochem Inc.	HD Expert™ Endurance	X				X	9,000 / 3	

TIM-ID: 0000115108 - 002

Manufacturer	Product/Brand name	Inhibitors					Runtime Hours/Years	Comments/ Material number
		Organic	Silicon	Nitrite	Phosphate	Molybdate		
Valvoline	Zerex G-30	X					9,000 / 3	
	OEM Advanced 30	X					9,000 / 3	
Volvo Trucks	Road Choice Nitrite-Free OAT Extended Life Coolant	X				X	9,000 / 3	

Table 44: Antifreeze – Concentrates for Series 2000Gx6 with intercooler option (TB)

Antifreeze – Ready mixtures for Series 2000Gx6 with intercooler option (TB)

Manufacturer	Product/Brand name	Inhibitors					Runtime Hours/Years	Comments/ Material number
		Organic	Silicon	Nitrite	Phosphate	Molybdate		
BASF SE	Glysantin G30 RM/50 ECO pink BMB 100	X					9,000 / 3	
CCI Corporation	L 415 (50%)	X				X	9,000 / 3	
Daimler Trucks North America	Alliance 50/50 Prediluted OAT Extended Life Coolant	X				X	9,000 / 3	
Detroit Diesel Corp.	Power Cool Plus Prediluted Coolant (50/50)	X				X	9,000 / 3	
Exxon Mobil	Mobil Delvac Extended Life Prediluted Coolant (50/50)	X				X	9,000 / 3	
Fast Chemical SRL	Fast Coolant G30 50 %	X					9,000 / 3	
Navistar Inc.	Fleetrite 50/50 Prediluted Nitrite-Free Life Coolant	X				X	9,000 / 3	
Old World Industries Inc.	Blue Mountain Heavy Duty Extended Life Prediluted Coolant (50/50)	X				X	9,000 / 3	
	Final Charge Global Extended Life Prediluted Coolant/ Antifreeze (50/50)	X				X	9,000 / 3	
Recochem	HD Expert™ Endurance 50-50 Prediluted	X				X	9,000 / 3	
Volvo Trucks	Road Choice 50/50 Prediluted Nitrite-Free OAT Extended Life Coolant	X				X	9,000 / 3	
YPF S.A. Argentina	Kriox MTL50	X				X	9,000 / 3	

Table 45: Antifreeze – Ready mixtures for Series 2000Gx6 with intercooler option (TB)

TIM-ID: 0000115 008 - 002

7.5 Antifreezes for cooling systems free of light metal

7.5.1 Antifreeze – Concentrates for cooling systems free of light metal

For details and special properties, see chapter on “Coolants” (→ Page 19)

Important
For Series 4000-04 (except genset) and 4000-05, only coolants marked with an asterisk * in the product/brand name may be used.

Antifreeze, concentrates

Manufacturer	Product/Brand name	Inhibitors							Runtime Hours/Years	Comments/ Material number
		Organic	Silicon	Nitrite	Phosphate	Molybdate	Borates	2-EHS		
Rolls-Royce Solutions GmbH	Coolant AO 100* Antifreeze Concentrate	X							9000 / 3	No longer included in portfolio. Remaining stocks of this product can be used up as long as the shelf life has not expired.
	Coolant AH 100* Antifreeze Concentrate	X	X				X	X	9000 / 5	No longer included in portfolio. Remaining stocks of this product can be used up as long as the shelf life has not expired.
Alliance Automotive Service GmbH	NAPA Premium Kühlerschutz N48*	X	X				X	X	9000 / 5	
Arteco NV	Havoline XLC (1040112)	X						X	9000 / 3	
Avia AG	Antifreeze APN - S*	X							9000 / 3	
	AVIA Coolant APN-S	X						X	9000 / 3	
BASF SE	Glysantin G05		X	X			X		9000 / 5	
	Glysantin G48 blue green*	X	X				X	X	9000 / 5	X00058054 (25 l) X00058053 (210 l)
	Glysantin G30 pink*	X							9000 / 3	X00058072 (canister) X00058071 (barrel)
	Glysantin G30 ECO pink BMB 100*	X							9000 / 3	
BayWa AG	Tectrol Coolprotect*	X	X				X	X	9000 / 5	
Castrol	Castrol Radicool NF*	X	X				X	X	9000 / 5	
CCI Corporation	L415*	X				X			9000 / 3	
Chevron	Delo XLC Antifreeze/ Coolant-Concentrate	X						X	9000 / 3	
COPARTS Autoteile GmbH	CAR1 Premium Longlife Kühlerschutz C48*	X	X				X	X	9000 / 5	

TIM-ID: 000019158 - 011

Manufacturer	Product/Brand name	Inhibitors							Runtime Hours/Years	Comments/ Material number
		Organic	Silicon	Nitrite	Phosphate	Molybdate	Borates	2-EHS		
Daimler Trucks North America	Alliance OAT Extended Life Coolant*	X				X			9000 / 3	
Detroit Diesel Corp.	Power Cool Plus Coolant*	X				X			9000 / 3	
	Power Cool Diesel Engine Coolant		X	X					9000 / 3	
Drew Marine	Drewgard ZX*	X							9000 / 3	
ExxonMobil	Mobil Delvac Extended Life Coolant*	X				X			9000 / 3	
	Mobil Heavy Duty Coolant		X	X					9000 / 3	
	Mobil Mining Coolant		X	X					9000 / 3	
Finke Mineralölwerk GmbH	AVIATICON Finkofreeze F30*	X							9000 / 3	
	AVIATICON Finkofreeze F48*	X	X				X	X	9000 / 5	
Fuchs SE	Maintain Fricofin*	X	X				X	X	9000 / 5	
	Maintain Fricofin G12 Plus*	X							9000 / 3	X00058074 (canister) X00058073 (barrel)
	Maintain Fricofin HDD [Oilcode T-AF3-1]	X	X	X			X		9000 / 3	
	Maintain Fricofin LL	X						X	9000 / 3	
	Pentofrost HD [Oilcode T-AF3-1]	X	X	X			X		9000 / 3	
	Titan Fricofin*	X	X				X	X	9000 / 5	
	Titan Fricofin G12 Plus*	X							9000 / 3	
	Titan Fricofin LL	X						X	9000 / 3	
Krafft S.L.U	Refrigerante ACU 2300		X	X			X		9000 / 3	X00058075 (barrel)
Kuwait Petroleum Research & Technology BV	Q8 Mahler Cool	X						X	9000 / 3	
	Roloil Rol-ICE SNF	X						X	9000 / 3	
LAEMMLE Chemicals AG	ROXOR ANTI-FROST MT-325*	X	X				X	X	9000 / 5	
Mitan Mineralöl GmbH	Alpine C30*	X							9000 / 3	
	Alpine C48*	X	X				X	X	9000 / 5	
MJL Bangladesh	Omera Premium Coolant*	X							9000 / 3	
MOFIN Deutschland GmbH & Co KG	MOFIN Kühlerschutz M48 Premium Protect*	X	X				X	X	9000 / 5	
Moove Lubricants Limited	Mobil Antifreeze Extra*	X	X				X	X	9000 / 5	
Nalco Water An Eco-lab Company	Nalcool NF 48 C*	X	X				X	X	9000 / 5	

Manufacturer	Product/Brand name	Inhibitors						Runtime Hours/Years	Comments/ Material number
		Organic	Silicon	Nitrite	Phosphate	Molybdate	Borates		
Navistar Inc.	Fleetrite Nitrite-Free Extended Life Coolant*	X				X		9000 / 3	
Old World Industries Inc.	Blue Mountain Heavy Duty Extended Life Coolant*	X				X		9000 / 3	
	Fleetcharge SCA Pre-charged Coolant / Antifreeze		X	X				9000 / 3	
	Final Charge Global Extended Life Coolant Antifreeze*	X				X		9000 / 3	
	Peak Heavy Duty Coolant		X	X				9000 / 3	
Penske Power Systems	Power Cool - HB500	X	X				X	9000 / 3	
	Power Cool - HB800	X	X	X			X	9000 / 3	
Puma Energy International S.A.	Puma HD XLC Coolant	X					X	9000 / 3	
Raloy Lubricantes	Antifreeze Long Life NF-300 Concentrate*	X	X				X	X	9000 / 5
Recochem Inc.	HD Expert™ Endurance*	X				X			9000 / 3
	R542	X	X				X		9000 / 3
	R824M	X	X	X			X		9000 / 3
Total Lubrifiants	Glacelf Auto Supra	X					X		9000 / 3
	Glacelf MDX*	X	X				X	X	9000 / 5
	Glacelf Supra	X					X		9000 / 3
Valvoline	Zerex G-05		X	X			X		9000 / 5
	Zerex G-30*	X							9000 / 3
	Zerex G-48*	X	X				X	X	9000 / 5
	OEM Advanced 05		X	X			X		9000 / 5
	OEM Advanced G 30*	X							9000 / 3
	OEM Advanced G 48*	X	X				X	X	9000 / 5
Volvo Trucks	Road Choice Nitrite-Free OAT Extended Life Coolant*	X				X			9000 / 3

Table 46:

7.5.2 Antifreeze – Ready mixtures for cooling systems free of light metals

For details and special properties, see chapter on “Coolants” (→ Page 19)

Important

For Series 4000-04 (except genset) and 4000-05, only coolants marked with an asterisk * in the product/brand name may be used.

Ready mixtures for light metal-free cooling systems

Manufacturer	Brand name	Inhibitors						Runtime Hours/Years	Comments/ Material number	
		Organic	Silicon	Nitrite	Phosphate	Molybdate	Borates			2-EHS
Rolls-Royce Solutions GmbH	Coolant AH 35/65 Anti-freeze Premix*	X	X				X	X	9000 / 5	No longer included in portfolio. Remaining stocks of this product can be used up as long as the shelf life has not expired.
	Coolant AH 40/60 Anti-freeze Premix*	X	X				X	X	9000 / 5	No longer included in portfolio. Remaining stocks of this product can be used up as long as the shelf life has not expired.
	Coolant AH 50/50 Anti-freeze Premix*	X	X				X	X	9000 / 5	No longer included in portfolio. Remaining stocks of this product can be used up as long as the shelf life has not expired.
Rolls-Royce Solutions America Inc.	Power Cool® Universal 35/65 mix*	X	X				X	X	9000 / 5	800085 (5 gallons) 800086 (55 gallons)
	Power Cool® Universal 50/50 mix*	X	X				X	X	9000 / 5	800071 (5 gallons) 800084 (55 gallons)
	Power Cool® Off-Highway Coolant 50/50 Premix		X	X			X		9000 / 5	23533531 (5 gallons) 23533532 (55 gallons)
A. Roth GmbH & Co KG	CRO Coolant Plus -25 °C Ready*	X							9000 / 3	

TIM-ID: 0000019-059-012

Manufacturer	Brand name	Inhibitors						Runtime Hours/Years	Comments/ Material number
		Organic	Silicon	Nitrite	Phosphate	Molybdate	Borates		
Arteco NV	Halvoline XLC Pre-mixed 50/50 (1033073)	X					X	9000 / 3	
	Halvoline XLC Pre-mixed 40/60 (1033069)	X					X	9000 / 3	
	Halvoline XLC + B2 35/65 (OF13) (2000214)	X					X	9000 / 3	
BASF SE	Glysantin G30 RM/50 ECO pink BMB 100*	X						9000 / 3	
BayWa AG	Tectrol Coolprotect Mix 3000*	X						9000 / 3	Antifreeze protection down to -24 °C
Castrol	Castrol Radicool NF Pre-mix (45 %)*	X	X				X X	9000 / 5	
CCI Corporation	L 415 (50 %)*	X				X		9000 / 3	
Cepsa Comercial Petróleo S.A.U.	Xtar Super Coolant Hybrid NF 50%*	X	X				X X	9000 / 5	
Daimler Trucks North America	Alliance 50/50 Prediluted OAT Extended Life Coolant*	X				X		9000 / 3	
Detroit Diesel Corp.	Power Cool Plus Prediluted Coolant (50/50)*	X				X		9000 / 3	
	Power Cool Prediluted 50/50 Diesel Engine Coolant		X	X				9000 / 3	
ExxonMobil	Mobil Delvac Extended Life Prediluted Coolant (50/50)*	X				X		9000 / 3	
	Mobile Heavy Duty 50/50 Prediluted Coolant		X	X				9000 / 3	
	Mobile Mining 50/50 Prediluted Coolant		X	X				9000 / 3	
Fast Chemical SRL	Fast Coolant G30 50%*	X						9000 / 3	
Finke Mineralölwerk GmbH	AVIATICON Finkofreeze F48 RM 50/50*	X	X				X X	9000 / 5	
	AVIATICON Finkofreeze F30 RM 40:60 +*	X						9000 / 3	
Fuchs SE	Maintain Fricofin 50 (Ready Mix)*	X	X				X X	9000 / 5	
	Maintain Fricofin HDD 50 [Oilcode T-AF3-2]	X	X	X			X	9000 / 3	
	Maintain Fricofin LL 50	X					X	9000 / 3	
	Titan Fricofin 50	X	X				X X	9000 / 5	
	Titan Fricofin LL 50	X					X	9000 / 3	

TUM-ID: 0000019159-012

Manufacturer	Brand name	Inhibitors						Runtime Hours/Years	Comments/ Material number	
		Organic	Silicon	Nitrite	Phosphate	Molybdate	Borates			2-EHS
Kuwait Petroleum Research & Technology BV	Q8 Mahler Cool premixed 4060	X					X	9000 / 3		
	Roloil Rol-ICE SNF 4060	X					X	9000 / 3		
Moove Lubricants Limited	Mobil Coolant Extra Ready Mixed -36 °C	X	X				X	X	9000 / 5	
Navistar Inc.	Fleetrite 50/50 Prediluted Nitrite-Free Extended Life Coolant*	X				X			9000 / 3	
Old World Industries Inc.	Blue Mountain Heavy Duty Extended Life Prediluted Coolant (50/50)*	X				X			9000 / 3	
	Final Charge Global Extended Life Prediluted Coolant / Antifreeze (50/50)*	X				X			9000 / 3	
	Fleet Charge SCA Pre-charged 50/50 Prediluted Coolant		X	X					9000 / 3	
Penske Power Systems	Power Cool - HB500 Premix 50/50	X	X				X		9000 / 3	
	Power Cool - HB500 35/65	X	X				X		9000 / 3	
	Power Cool - HB800 Premix 50/50	X	X	X			X		9000 / 3	
	Power Cool - HB800 35/65	X	X	X			X		9000 / 3	
Puma Energy International S.A.	Puma HD XLP Coolant	X					X		9000 / 3	50% premix
Raloy Lubricantes	Antifreeze Long Life NF-300 Ready-to-Use (50:50)*	X	X				X	X	9000 / 5	
Recochem	HD Expert™ Endurance 50-50 Prediluted*	X				X			9000 / 3	
	R542 35/65	X	X				X		9000 / 3	
	Turbo Power R824 M 35/65	X	X	X			X		9000 / 3	

TIM-ID: 0000019-059-012

Manufacturer	Brand name	Inhibitors							Runtime Hours/Years	Comments/ Material number	
		Organic	Silicon	Nitrite	Phosphate	Molybdate	Borates	2-EHS			
Total Lubrificants	Coollef Auto Supra -26 °C	X						X	9000 / 3	40/60 premix	
	Coollef MDX -26 °C*	X	X					X	X	9000 / 5	
	Coollef Auto Supra -37 °C							X	9000 / 3	50/50 premix	
	Coollef MDX -37 °C*	X	X					X	X	9000 / 5	
	Coollef Supra (40%)	X						X	9000 / 3		
	Coollef Supra GF NP (50 %)	X						X	9000 / 3		
Valvoline	Zerex G-05 50/50 Mix		X	X				X	9000 / 5		
	Zerex G-48 premix 50%*	X	X					X	X	9000 / 5	
	OEM Advanced 48 pre-mix 50%*	X	X					X	X	9000 / 5	
Volvo Trucks	Road Choice 50/50 Pre-diluted Nitrite-Free OAT Extended Life Coolant*	X				X			9000 / 3		
YPF S.A. Argentina	Kriox MTL50*	X				X			9000 / 3		

Table 47:

7.6 Coolant Additives with Limited Series Approval

7.6.1 Antifreeze – Concentrates and ready mixtures on ethylene-glycol basis for engines with and without light metal

Important

The antifreezes listed below can be used at an application concentration of 40 – 50% by volume.

Exception:

- For model type 00 to 07 Series 2000 marine engines no more than 40% by volume is admissible.

Antifreeze, concentrates

Manufacturer	Brand name	Inhibitors						Runtime Hours/Years	Comments/ Material number
		Organic	Silicon	Nitrite	Phosphate	Molybdate	Borates		
Rolls-Royce Solutions GmbH	Coolant AS 100 Antifreeze Concentrate	X	X					9000 / 3	No longer included in portfolio. Remaining stocks of this product can be used up as long as the shelf life has not expired.
BASF SE	Glysantin®G40 pink (concentrate)	X	X					9000 / 3	X00066724 (20 l) X00066725 (210 l)
	Glysantin®G40 ECO pink BMB 100	X	X					9000 / 3	
Finke Mineralölwerk GmbH	AVIATICON Finkofreeze F40	X	X					9000 / 3	
Fuchs SE	Maintain Fricofin DP	X	X					9000 / 3	
	Titan Fricofin DP	X	X					9000 / 3	
LAEMMLE Chemicals AG	Roxor Anti-Frost MT-650	X	X					9000 / 3	
MOFIN Deutschland GmbH & Co KG	MOFIN Kühlerschutz M40 Extra	X	X					9000 / 3	
Puma Energy International S.A.	Puma HD Hybrid Coolant	X	X					9000 / 3	
Valvoline	ZEREX G40 (concentrate)	X	X					9000 / 3	Material number (USA): 800180 (Drum)
	OEM Advanced 40	X	X					9000 / 3	

Table 48:

Antifreeze, ready mixtures

Manufacturer	Brand name	Inhibitors						Runtime Hours/Years	Comments/ Material number
		Organic	Silicon	Nitrite	Phosphate	Molybdate	Borates		
BASF SE	Glysantin®G40 RM/50 ECO pink BMB 100	X	X					9000 / 3	(50% by vol.)
Fuchs SE	Maintain Fricofin DP 50	X	X					9000 / 3	(50% by vol.)
	Titan Fricofin DP 50	X	X					9000 / 5	
Puma Energy International S.A.	Puma HD Hybrid Coolant 5050	X	X					9000 / 3	(50% by vol.)

Table 49:

7.6.2 Antifreeze – Ready mixtures based on propylene glycol for engine series not containing light metal

Important

Propylene glycol based coolants (→ Page 147) are approved for Series 4000 model types 01 to 05 used in genset applications.

Restrictions apply to the use of propylene glycol based coolants for various model types in all other Series 4000 applications. See (→ Page 124)

For Series 4000C01 to C03 and 4000R01 to R03 only an application concentration of 40% is admissible. A 50/50 mixture must not be used.

Antifreeze, ready mixture

Manufacturer	Brand name	Inhibitors						Runtime Hours/Years	Comments/ Material number
		Organic	Silicon	Nitrite	Phosphate	Molybdate	Borates		
Fleetguard	PG XL (40%) ready mixture	X	X	X	X	X	X	9000 / 3	
	ES Compleat PG Premix 50/50	X	X	X	X	X	X	9000 / 3	

Table 50:

8 Flushing and Cleaning Specifications for Engine Coolant Circuits

8.1 General information

Over time, sludge deposits from aging coolant additives can accumulate in the coolant circuits. Reduced cooling capacity, clogged vent lines and drain points, and dirty coolant level sight glasses can result.

Inadequate water quality or incorrect coolant preparation can also heavily contaminate the cooling circuit.

If such conditions occur, the coolant circuit must be flushed out with freshwater, repeatedly if necessary.

If these flushing processes are insufficient or if the system is too heavily contaminated, the coolant circuit and all affected assemblies must be cleaned.

Only clean freshwater (no river or seawater) must be used for flushing.

Only products approved by Rolls-Royce Solutions or equivalent products at the specified concentrations may be used for cleaning, see (→ Page 150). The specified cleaning procedure is mandatory.

Immediately after flushing or cleaning, fill the coolant circuits with prepared engine coolant as stipulated in the current Fluids and Lubricants Specifications. Otherwise there is a danger of corrosion!

Important

Fluids and lubricants (e.g. treated engine coolant), used flushing water, cleaning agents, and cleaning solutions can be hazardous materials. Certain regulations must be observed when handling, storing and disposing of these substances.

These regulations are contained in the manufacturer's instructions, statutory requirements, and technical guidelines valid in the individual countries. Considerable differences can apply from country to country so that no generally valid statement on the applicable regulations for fluids and lubricants etc. can be made in this publication.

Users of the products named in these specifications are therefore obliged to inform themselves of the locally applicable regulations. Rolls-Royce Solutions accepts no liability whatsoever for improper or illegal use of the fluids and lubricants/cleaning agents which it has approved.

Important

Oil heat exchangers from engines with bearing or piston seizures or friction damage must be scrapped!

Test equipment, auxiliary materials, and fluids and lubricants

Test kit or electrical pH meter

Important

Rolls-Royce Solutions recommends the diesel engine test kit from CMT-Technologie GmbH ([/https://www.cmttechnologies.de](https://www.cmttechnologies.de)).

Required auxiliary materials:

- Compressed air
- Superheated steam

Required fluids and lubricants:

- Freshwater
- Prepared engine coolant

8.2 Freshwater requirements for cleaning solutions and flushing water

Important

Only clean, clear water with values in accordance with those in the following table must be used for preparing cleaning solutions. If the limit values for the water are exceeded, hardness or mineral content can be decreased by adding demineralized water.

The cleaning agent concentrates used for the preparation of the cleaning solution must not contain more than 100 mg/l chloride and/or 100 mg/l sulfate.

Item	Minimum	Maximum
Total earth alkalines ¹⁾ (water hardness)	0 mmol/l 0°d	2.7 mmol/l 15° d
pH value at 20 °C	5.5	8.0
Chloride ions		100 mg/l
Sulphate ions		100 mg/l
Total chloride + sulfate ions		200 mg/l
Bacteria		10 ³ CFU (colony forming unit)/ml
Fungi, yeasts	Not permitted!	

Table 51: Values for freshwater

¹⁾ = Common designations for water hardness in various countries: 1 mmol/l = 5.6°d = 100 mg/kg CaCO₃

- 1°d = 17.9 mg/kg CaCO₃, USA hardness
- 1°d = 1.79° French hardness
- 1°d = 1.25° English hardness

8.3 Approved cleaning agents

Manufacturer	Product name	Working concentration		Order no.
For coolant systems:				
Kluthe	Hakutex 111 ^{1,5)}	2% by volume	Liquid	X00065751
	Decorrdal 20-1 ⁸⁾	10% by volume	Liquid	⁷⁾
	Hakupur 50-706-3 ⁴⁾	2% by volume	Liquid	X00055629
For cooling circuit assemblies:				
Henkel	Bonderite C-AK FD ²⁾	1 to 10% by weight	Powder	⁷⁾
	Bonderite C-MC 11120 ³⁾	2 to 10% by weight	Powder	⁷⁾
Kluthe	Hakutex 60 mtu ⁹⁾	100% by volume	Liquid	X00070585 (25 kg)
For coolant circuits contaminated with bacteria, fungi or yeast:				
Thor	Acticide MV14 ⁶⁾	0.01% by volume	Liquid	X00079756 (20 l)
Thor	Acticide MV ¹⁰⁾	0.1% by volume	Liquid	X00088729 (5 l)

Table 52: Approved cleaning agents

¹⁾ For light lime deposits, light corrosion

²⁾ For lime deposits containing oil and grease

³⁾ Preferred for heavy lime deposits

⁴⁾ For oily and greasy residues. Not suitable for galvanized surfaces

⁵⁾ Bacteria contamination up to 10^4

⁶⁾ Bacteria contamination up to $> 10^4$, contamination with fungi and yeast
Note application cases (→ Page 155).

⁷⁾ Not stocked by Rolls-Royce Solutions.

⁸⁾ With serious corrosion; not permitted for aluminum materials

⁹⁾ Solvent cold cleaner for oily and greasy residues

¹⁰⁾ For use in the field. The smaller canister is easier to handle.
Note application cases (→ Page 155).

Important

The technical data sheets and safety data sheets of the product must be observed!

The cleaning agents are available world-wide through the branches of the manufacturers or their trading partners.

8.4 Engine coolant circuits – Flushing

1. Drain engine coolant.
2. Measure pH value of the freshwater using the mtu test kit (→ Table 53) or electrical pH meter.

Important

Rolls-Royce Solutions recommends the diesel engine test kit from CMT-Technologie GmbH (<https://www.cmttechnologies.de>).

Table 53:

3. Fill coolant circuit with freshwater.

Important

Do not pour cold water into a hot engine!
Refer to the Operating Instructions of the engine for additional information.

4. Preheat, start, and run engine until warm.
5. Run engine for approx. 30 minutes at increased speed.
6. Stop engine.
7. Take flushing water sample at engine-coolant-sample extraction cock.
8. Drain flushing water.
9. Measure pH value of flushing water sample using the mtu test kit (→ Table 53) or electrical pH meter and compare with the pH value of the freshwater.
 - a) pH value difference < 1: Fill system with treated coolant and start engine.
 - b) pH value difference > 1: Fill system with fresh flushing water and repeat flushing process.
 - c) If the pH value difference is still > 1 after 4 to 5 flushing operations: Clean the coolant circuit, see (→ Page 152). The assemblies may also have to be cleaned, see (→ Page 154).

8.5 Engine coolant circuits – Cleaning

1. Mix cleaner to the specified concentration with freshwater. Use warm freshwater (45 °C) if the engine is warm.
2. Cleaning agents for coolant circuits are prepared in warm freshwater as a concentrated solution, see (→ Page 150).
3. In the case of powdered products, stir until the cleaning agent is completely dissolved and without sediment.
4. Pour solution together with freshwater into coolant circuit.
5. Start engine and run until warm.
6. Select temperature and duration of reaction time according to the specifications in the technical data sheets of the manufacturer.
7. Stop engine.
8. Drain off cleaning agents and flush the engine coolant circuit with fresh water.
9. Take flushing water sample at engine-coolant-sample extraction cock.
10. Measure pH value of flushing water sample using the mtu test kit (→ Table 54) or electrical pH meter and compare with the pH value of the freshwater.
 - a) pH value difference < 1: Fill system with treated coolant and start engine.
 - b) pH value difference > 1: Clean assemblies, see (→ Page 154).

Important

Rolls-Royce Solutions recommends the diesel engine test kit from CMT-Technologie GmbH ([/https://www.cmttechnologies.de](https://www.cmttechnologies.de)).

Refer to the Operating Instructions of the engine for additional information.

Table 54:

8.6 Removal of heavy corrosion in coolant circuits using Decorrda 20-1

1. Drain all coolant from engine coolant circuit.
2. Fill engine coolant circuit with fresh water and flush the cooling system.
3. Drain flush water completely.
4. Fill coolant circuit completely with a water solution containing 10% Decorrda 20-1.
5. Start engine and run to operating temperature, 20 minutes.
6. Perform cleaning cycle with the engine running, with circulating Decorrda 20-1, duration: 4 hours.
7. Vent the coolant circuit several times while running the cleaning cycle to ensure complete filling.
8. Allow the engine to cool down to approx. 45 °C.
9. When the temperature reaches 45 °C, drain Decorrda 20-1.
10. First flushing cycle: Fill the coolant circuit with 10% Glysacorr P113 solution in water immediately after draining the cleaning solution.
11. Operate the engine for 30 minutes, vent the coolant circuit several times.
12. Allow the engine to cool down to 45 °C.
13. Drain the Glysacorr P113 flushing solution completely.
14. Second flushing cycle: Fill coolant circuit again with a fresh water solution containing 10% Glysacorr P113.
15. Operate the engine for 30 minutes, vent the coolant circuit several times.
16. Allow the engine to cool down to 35 °C.
17. Drain the Glysacorr P113 flushing solution completely.
18. Fill engine with coolant.
19. Rust removal is complete.
20. Put engine into operation.

Important

The engine coolant circuit must always be vented properly to ensure complete filling. This applies when filling the engine with water, cleaning agent, corrosion inhibitor and coolant as well as in engine operation with one of the mentioned media.

In zones where air is present, neither rust removal nor preservation take place, and corrosion occurs again. All crankcase openings, hose connection openings, etc. must be closed immediately if no longer required. There is a risk of corrosion in the area of the openings.

8.7 Cleaning engine coolant circuit assemblies

1. Remove, disassemble and clean assemblies in the engine coolant circuit that are exposed to heavy sludge deposits e.g. expansion tanks, preheating units, heat exchangers (coolant cooler, oil heat-exchanger, charge-air cooler, charge-air preheater, fuel preheater etc.) and lower sections of pipework.
2. Before cleaning, examine degree of contamination on water sides.
3. In case of lime deposits that contain oil and grease, degrease the water side first.
4. Deposits in charge-air coolers caused by oil mist can be removed using Kluthe Hakutex 60.
5. Remove hard lime deposits with a decalcifying product. In the event of stubborn lime deposits, if necessary a 10% inhibited hydrochloric acid solution may have to be used.
6. Dissolve deposits on and in heat-exchanger elements in a heated cleaning bath. Observe the manufacturer's specifications and use only approved detergents in the permissible concentration, see (→ Page 150)

Important

Deposits on the oil side can also be dissolved in a kerosene bath.
The dwell time in the cleaning bath depends on the type and degree of contamination, as well as the temperature and activity of the bath.

7. Clean individual components such as housings, covers, pipes, sight glasses, heat-exchanger elements with superheated steam, a nylon brush (soft) and a powerful water jet.

Important

In order to avoid damage:
Do not use hard or sharp-edged tools (steel brushes, scrapers, etc.) (oxide protective layer).
The pressure of the water jet must not be ≤ 60 bar (to avoid damage, e.g. of the cooler fins).

8. After cleaning, blow through the heat exchanger elements with low-pressure steam in the direction opposite to operational flow, rinse with clear water (until pH-value difference is < 1) and blow dry with compressed or hot air.
9. Check that all components are in perfect condition, repair or replace as necessary.
10. Flush oil and engine coolant sides of heat-exchanger elements with corrosion-inhibiting oil. This step may be omitted if the heat exchanger is installed and taken into service immediately after cleaning.
11. After installing all assemblies, flush engine coolant circuit once, see (→ Page 151).
12. Check coolant system for leaks during initial operation of engine.

Important

For further information, see the Maintenance Manual for the engine in question.

8.8 Coolant circuits contaminated with bacteria, fungi or yeast

Disinfection and prevention

Microbiologically contaminated systems:

The disinfecting agent is added to the contaminated coolant.

The prerequisite for effective disinfection of the engine coolant system is that the disinfecting agent has a sufficiently long reaction time and can reach all areas of the cooling system. All external storage tanks and pipes must also be reached by the disinfecting agent.

Dwell time: Not less than 12 hours

Temperature: Maximum temperature 55 °C (higher temperatures destroy the disinfecting agent)

Prevention:

If an engine is to be shutdown for a long period, disinfecting agent can be added as a preventive measure. Before the engine is put back into operation, always ensure that the coolant is still in good condition. During return to operation, the coolant containing disinfecting agent can remain in the system and be reused.

The dosing (→ Page 150) and work safety specifications must be strictly observed.

Flushing

When the coolant is drained, the cooling circuit must be flushed with freshwater. The coolant circuit must be flushed as long as visible contamination can be detected and the flushing water has the same pH value as the fresh water used (maximum deviation of pH value < 1).

Refill

Before refilling with coolant, ensure that the cooling system is free of contaminants.

Refilling must be performed directly after flushing to avoid the risk of corrosion!

9 Cleaning the Product Externally

9.1 General information

If, in the course of time, contaminants such as oil deposits and leaves have accumulated on the engine, it can be necessary to clean it. Clean the engine only superficially and with great care.

Wash-cleaning the engine can – at the worst – have the opposite effect if carried out incorrectly.

To prevent damage, observe the following before starting work and applying cleaning agents:

- Protect electrical components (battery-charging generator, plug connections, ignition cables, etc.) and the intake area from undesirable water ingress in plug connections or the combustion chamber,

Only clean freshwater (no river or seawater) must be used for spray-washing.

Check all plug connections and, if necessary, blow out with compressed air after cleaning to avoid misfiring and other electrical issues.

Only products approved by Rolls-Royce Solutions GmbH in the specified concentrations can be used for cleaning. The specified cleaning procedure is mandatory.

Important

Cleaning must be carried out with pressure washers at an operating pressure of ≤ 60 bar to avoid damaging the cooler and the engine. High-pressure cleaners with an operating pressure > 60 bar are not permitted. After washing, the equipment must be thoroughly rinsed with freshwater. The specifications in chapter 9.2 “Freshwater requirements for cleaning solutions and flushing water” apply (→ Page 149).

The technical data sheets and safety data sheets of the product must be observed!

Fluids and lubricants (e.g. treated engine coolant), used flushing water, cleaning agents, and cleaning solutions can be hazardous materials. Certain regulations must be observed when handling, storing, and disposing of these substances.

These regulations are contained in the manufacturer's instructions, statutory requirements, and technical guidelines valid in the individual countries. Great differences can apply from country to country, and a generally valid statement on applicable regulations is therefore not possible within these flushing and cleaning specifications.

Users of the products named in these specifications are therefore obliged to inform themselves of the locally applicable regulations. Rolls-Royce Solutions GmbH accepts no liability whatsoever for improper or illegal use of the fluids and lubricants / cleaning agents which it has approved.

Test equipment, auxiliary materials, and fluids and lubricants

Important

Rolls-Royce Solutions recommends the diesel engine test kit from CMT-Technologie GmbH ([/https://www.cmttechnologies.de](https://www.cmttechnologies.de)).

Table 55:

Test kit (→ Table 55) or electrical pH meter

- Freshwater
- Superheated steam
- Compressed air

9.2 Approved cleaning agents

Manufacturer	Product name	Working concentration		Order no.
For remote cooler on air side:				
Kluthe GmbH	Hakupur 50 K ¹⁾	0.5% by volume - 5% by volume	Liquid	X00070940 ²⁾
For cleaning painted, contaminated surfaces externally:				
Kluthe GmbH	Hakupur 449 ³⁾	1% by volume	Liquid	X00071179 ²⁾

Table 56: Approved cleaning agents

¹⁾ Cleaning agent for cleaning with pressure cleaner (parameters: Pressure: ≤ 60 bar, gentle spray jet, distance from nozzle to object at least 25 cm, cleaning agent temperature: 80 °C).

²⁾ Not stocked by Rolls-Royce Solutions.

³⁾ The cleaner is unsuitable for components made of aluminum materials (e.g. Al coolers) and must not be used.

Important

The technical data sheets and safety data sheets of the product must be observed!

The cleaning agents are available world-wide through the branches of the manufacturers or their trading partners.

10 Revision Overview

10.1 Revision overview from version A001064/13 to version A001064/14

Seq. no.	Chapter	Subject	Page	Action
1	1.1	General information	(→ Page 5)	Revised
2	2.1	Engine oils – General information	(→ Page 8)	Revised
3	2.4	Fluorescent dyestuffs for detecting leakage in the lube oil circuit	(→ Page 16)	Revised
4	2.3	Lubricating greases	(→ Page 17)	Updated
5	3.1	Coolants – General information	(→ Page 19)	Revised
6	3.7	Operational monitoring	(→ Page 31)	Revised
7	3.9	Coolant concentrates – Storage stability	(→ Page 36)	Updated
8	4.1	Diesel fuels – General information	(→ Page 40)	Revised
9	4.2.2	British Standard 2869	(→ Page 49)	Revised
10	4.2.8	Paraffinic diesel fuel in accordance with EN 15940	(→ Page 60)	Revised
11	4.6	Fuel additives	(→ Page 74)	Updated
12	4.7	Unsuitable materials in the diesel fuel circuit	(→ Page 78)	Revised
13	6.1	Single-grade oils – Category 1, SAE grades 30 and 40 for diesel engines	(→ Page 83)	Updated
14	6.2	Multi-grade oils – Category 1, SAE grade 15W-40 for diesel engines	(→ Page 85)	Updated
15	6.3	Single-grade oils – Category 2, SAE grades 30 and 40 for diesel engines	(→ Page 86)	Updated
16	6.4	Multi-grade oils – Category 2, SAE grades 10W-30, 10W-40, 15W-40 and 20W-40 for diesel engines	(→ Page 90)	Updated
17	6.5	Multi-grade oils – Category 2.1 (low SAPS oils), SAE grades 0W-30, 10W-30, 5W-40, 10W-40 and 15W-40 for diesel engines	(→ Page 103)	Updated
18	6.6	Multi-grade oils – Category 3, SAE grades 5W-30, 5W-40, 10W-40 and 15W-40 for diesel engines	(→ Page 110)	Updated
19	6.7	Multi-grade oils – Category 3.1 (low SAPS oils), SAE grades 5W-30, 10W-30 and 10W-40 for diesel engines	(→ Page 115)	Updated
20	7.2.1	Coolant without antifreeze – Concentrates for cooling systems containing light metal	(→ Page 125)	Updated
21	7.2.2	Coolant without antifreeze – Ready mixtures for cooling systems containing light metal	(→ Page 126)	Updated
22	7.3.1	Coolants without antifreeze – Concentrates for cooling systems free of light metal	(→ Page 127)	Updated
23	7.3.2	Coolant without antifreeze – Ready mixtures for cooling systems free of light metal	(→ Page 129)	Updated
24	7.4.1	Antifreeze – Concentrates for cooling systems containing light metal	(→ Page 130)	Updated

Seq. no.	Chapter	Subject	Page	Action
25	7.4.2	Antifreeze – Ready mixtures for cooling systems containing light metal	(→ Page 133)	Updated
26	7.4.3	Antifreeze – Approved coolants for Series 2000Gx6 with intercooler option (TB)	(→ Page 136)	Updated
27	7.5.1	Antifreeze – Concentrates for cooling systems free of light metal	(→ Page 138)	Updated
28	7.5.2	Antifreeze – Ready mixtures for cooling systems free of light metal	(→ Page 141)	Updated
29	7.6.1	Antifreeze – Concentrates and ready mixtures on ethylene-glycol basis for engines with and without light metal	(→ Page 145)	Updated
30	8.1	Flushing and cleaning specifications for engine coolant circuits: General information	(→ Page 148)	Updated
31	8.4	Engine coolant circuits – Flushing	(→ Page 151)	Revised
32	8.5	Engine coolant circuits – Cleaning	(→ Page 152)	Revised
33	9.1	Cleaning the product externally: General information	(→ Page 156)	Revised
34	9.2	Approved cleaning agents	(→ Page 157)	Updated

11 Index

11.1 Index

A

Additives

- Biocide 74
- Supplementary fuel additives 74
- Wear protection 74

Approved diesel fuels

- ASTM D975 46
- Aviation turbine fuels 55
- British Standard 2869 49
- Chinese distillate fuels 50
- EN 590 46
- Heating oil 52
- Marine distillate fuels 53
- NATO diesel fuels 56

B

Biodiesel 68

C

Cleaning

- General information 156

Cleaning agents 150, 157

- System cleaners 155

Cleaning specifications

- Assemblies 154
- Engine coolant circuit 148, 152, 153
- System cleaners 155

Color additive

- Coolant circuit 37

Coolant

- Test kit 148
 - Antifreeze 28
 - Concentrates for cooling systems containing light metal 130, 136
 - Concentrates for cooling systems free of light metal 138
 - Ready mixtures for cooling systems containing light metals 133
 - Ready mixtures for cooling systems free of light metal 141
 - Antifreeze, limited approval for engine series
 - Concentrates and ready mixtures on ethylene-glycol basis 145
 - Antifreeze, limited series approval
 - Ready mixtures based on propylene glycol 147
 - Approved coolants
 - Series-based overview 124
 - Coolant without antifreeze
 - Concentrates for cooling systems containing light metal 125
 - Concentrates for cooling systems not containing light metal 127
 - Ready mixtures for cooling systems containing light metal 126
 - Ready mixtures for cooling systems not containing light metal 129
 - Cooling system 124
 - Corrosion protection 19
 - Emulsifiable corrosion-inhibiting oil 27
 - Fresh water requirements 26
 - Limit values 35
 - Operational monitoring 31
 - pH value 35
 - Storage capability 36
 - Test kit 31
 - Test package for North America 38
 - Treatment 26
 - Usability 124
- #### Coolant circuit
- Assembly cleaning 154
 - Cleaning 148, 152, 153
 - Cleaning agents 150, 157
 - Flushing 151
 - Leakage 37
 - Materials 25

Coolant without antifreeze

- Antifreeze 30

Coolants

- Coolants 19

Cooling system

- Damage prevention 19
- Preservation 19

D

Diesel fuel 74

- Approved diesel fuels
 - ASTM D975 46
 - Aviation turbine fuels 55
 - British Standard 2869 49
 - Chinese distillate fuels 50
 - EN 590 46
 - Heating oil 52
 - Marine distillate fuels 53
 - NATO diesel fuels 56
- B20 63
- Biodiesel 68
- Heating oil EL 73
- Quality 40
- Requirement 40
- Supplementary fuel additives 74
- Test package for North America 79

Disposal 5

Dye additives

- Lube oil circuit 16

E

EN 15940

- Paraffinic diesel fuel 60

Engine coolant circuit

- Assembly cleaning 154
- Cleaning 152, 153
- Cleaning agents 150
- Contamination 148

Engine coolant circuits

- Flushing 151

Engine oil

- Analysis 8
- Approved engine oils
 - Series-based overview 15
- Low SAPS
 - Category 3.1 115
- Low SAPS oils
 - Caterogy 2.1 103
- Multi-grade oil
 - Category 1 85
 - Category 2 90
 - Category 2.1 (Low SAPS oils) 103
 - Category 3 110
 - Category 3.1 (Low SAPS oil) 115
- Oil category 8, 15
- Oil change interval 8
- Requirements 8
- Single-grade oil
 - Category 1 83
 - Category 2 86
- Test kit 8
- Test package for North America 18
- Usability 15
- Viscosity 8

Engine wash-cleaning procedure

- Cleaning agents 157

F

FAME 68

Flushing specifications

- Assemblies 154
- Coolant circuits contaminated with bacteria, fungi or yeast 155
- Engine coolant circuit 148
- Engine coolant circuits 151

Fresh water

- Limit values 26
- Requirements 26

Fuel system

- Materials 78

Fuel, see diesel fuel 40

Fuels

- Diesel fuels 71

H

Heating oil EL 73

L

Leakage

- Coolant circuit 37
- Lube oil circuit 16

Lube oil circuit

- Leakage 16

Lubricating grease

- ATS 123
- Coolant cooler 123
- General application 17, 122
- Generator 123
- Requirements 17
- Special application 17

m

mtu Advanced Fluid Management System

- Coolant 38
- Diesel fuel 79
- Engine oil 18

M

Materials

- Coolant circuit 25
- Fuel system 78

N

NOx reducing agent AUS 32/AUS 40 for SCR systems

- General information 81

O

Oil change interval

- Biodiesel operation 68
- Overview 8

Operational monitoring

- Coolant 31
- Diesel fuel 40
- Engine oil 8

P

Preservation 5

R

Requirements

- Coolant circuit 25
- Fuel system 78

Revision overview 158

S

Storage

- Coolant 36

T

Test kit

- Coolant 148
- Engine oil 8

Test package for North America

- Coolant 38
- Diesel fuel 79
- Engine oil 18

U

User instructions 5

V

Versioning of this publication 5