



Fluids and Lubricants Specifications

Diesel engine-generator sets
with mtu Series 1600 engines

A001068/04E



Rolls-Royce Solutions refers to Rolls-Royce Solutions GmbH or an affiliated company pursuant to §15 AktG (German Stock Corporation Act) or a controlled company (joint venture), and Rolls-Royce Solutions Ruhstorf GmbH.

© Copyright Rolls-Royce Solutions

This publication is protected by copyright and may not be used in any way, whether in whole or in part, without the prior written consent of Rolls-Royce Solutions. This particularly applies to its reproduction, distribution, editing, translation, microfilming and storage and/or processing in electronic systems including databases and online services.

All information in this publication was the latest information available at the time of going to print. Rolls-Royce Solutions reserves the right to change, delete or supplement the information provided as and when required.

Table of Contents

1	Preface		6	Approved Engine Oils and Lubricating Greases		
1.1	General information	4		6.1	Multi-grade oils – Category 2 of SAE grades 10W-40, 15W-40 and 20W-40 for diesel engines	41
2	Engine Oils			6.2	Multi-grade oils – Category 2.1 (Low SAPS oils), SAE grades 0W-30, 10W-30, 5W-40, 10W-40 and 15W-40	50
2.1	Requirements and oil change intervals	6		6.3	Multi-grade oils – Category 3, SAE grades 5W-30, 5W-40, 10W-40 and 15W-40 for diesel engines	54
2.2	Viscosity grades	8		6.4	Multi-grade oils – Category 3.1 (Low SAPS oils), SAE grades 5W-30, 10W-30 and 10W-40 for diesel engines	59
2.3	Series-dependent usability of engine oils	9		6.5	Lubricating greases for diesel engine-generator set components	65
2.4	Used-oil analysis	10		7	Approved Coolants	
2.5	mtu Advanced Fluid Management System for engine oils – Test package for North America	12		7.1	Antifreeze concentrates on ethylene glycol basis	66
3	Coolants			7.2	Antifreeze ready mixtures on ethylene glycol basis	69
3.1	Coolant – General	13		8	Flushing and Cleaning Specifications for Engine Coolant Circuits	
3.2	Unsuitable materials in the coolant circuit	15		8.1	General information	71
3.3	Requirements imposed on freshwater	16		8.2	Approved cleaning agents	72
3.4	Operational checks	17		8.3	Engine coolant circuits – Flushing	73
3.5	Storage capability of coolant concentrates	18		8.4	Engine coolant circuits – Cleaning	74
3.6	Color additives to detect leakage in the coolant circuit	19		8.5	Cleaning engine coolant circuit assemblies	75
3.7	Series-dependent usability of coolant additives	20		8.6	Coolant circuits contaminated with bacteria, fungi or yeast	76
3.8	mtu Advanced Fluid Management System for coolant – Test package for North America	21		9	Cleaning	
4	Liquid Fuels			9.1	General information	77
4.1	Diesel fuels – General information	23		9.2	Approved cleaning agents	78
4.2	Biodiesel - biodiesel admixture	27		10	Revision Overview	
4.3	Heating oil EL	28		10.1	Revision overview from version A001068/03 to version A001068/04	79
4.4	Supplementary fuel additives	29		11	Index	
4.5	Series-dependent approval of diesel fuel grades for mtu engines	31		11.1	Index	80
4.6	Unsuitable materials in the diesel fuel circuit	36				
4.7	Measures prior to engine out-of-service periods >1 month	37				
4.8	mtu Advanced Fluid Management System for fuels – Test package for North America	38				
5	NOx Reducing Agent AUS 32 / AUS 40 for SCR Exhaust Gas Aftertreatment Systems					
5.1	General information and storage	40				

1 Preface

1.1 General information

Used symbols and means of representation

The following instructions are highlighted in the text and must be observed:

Important

This field contains product information which is important or useful for the user. It refers to instructions, work and activities that have to be observed to prevent damage or destruction to the material.

Note:

A note provides special instructions that must be observed when performing a task.

Fluids and lubricants

The operational life, operational reliability and function of the drive systems are largely dependent on the fluids and lubricants employed. The correct selection and treatment of these fluids and lubricants are therefore extremely important.

Test standard	Designation
DIN	Federal German Standards Institute
EN	European Standards
ISO	International Standards Organization
ASTM	American Society for Testing and Materials
IP	Institute of Petroleum
DVGW	German Gas and Water Industry Association

Table 1: Test standards for fluids and lubricants

Applicability of this document

These Fluids and Lubricants Specifications apply to fluids and lubricants for diesel engine-generator sets with the following mtu engines:

- Series 1600Gx0

Note: References to other engine series in this document should be disregarded.

Applicability of this publication

The Fluids and Lubricants Specifications will be amended or supplemented as necessary. Before using them, make sure you have the latest version (publication number A00 1068/..). The latest version is available at: <http://www.mtu-solutions.com>.

If you have any questions, your contact person will be happy to help you.

Warranty

Use of the approved fluids and lubricants, either under the brand name or in accordance with the specifications given in this publication, constitutes part of the warranty conditions.

The supplier of the fluids and lubricants is responsible for the worldwide standard quality of the named products.

Important

Fluids and lubricants for diesel engine-generator sets can be hazardous materials. Certain regulations must be obeyed when handling, storing and disposing of these substances.

These regulations are contained in the manufacturers' instructions, legal requirements and technical guidelines valid in the individual countries. Great differences can apply from country to country and a generally valid guide to applicable regulations for fluids and lubricants is therefore not possible within this publication.

Users of the products named in these specifications are therefore obliged to inform themselves of the locally valid regulations. Rolls-Royce Solutions accepts no liability whatsoever for improper or illegal use of the fluids and lubricants which it has approved.

Rolls-Royce Solutions recommends consultation with the suppliers of all fluids and lubricants to request the relevant safety data sheets prior to storing, handling and using these fluids and lubricants.

Safe disposal

Important

To prevent environmental pollution and infringements of statutory requirements, used fluids and lubricants must be disposed of in accordance with local regulations.

Never dispose of or burn the used oil in the fuel tank.

The regulations for the disposal of fluids and lubricants differs from place to place. Environmental protection is one of the fundamental corporate objectives of Rolls-Royce Solutions. We therefore recommend the recycling of fluids and lubricants wherever possible. If recycling is not available, Rolls-Royce Solutions recommends contacting the local waste disposal authority, before disposing of any fluids and lubricants to determine the best option. Users of the products named in these specifications are therefore obliged to inform themselves of the locally valid regulations. Rolls-Royce Solutions accepts no liability whatsoever for improper or illegal use of the fluids and lubricants which it has approved.

Registered trademarks

All brand names are registered trademarks of the manufacturer concerned.

Preservation

All information on preservation, represervation and depreservation including the approved preservatives is available in the Preservation and Represervation Specifications (publication number A001070/...). The most recent version can be consulted under:

<http://www.mtu-solutions.com>

2 Engine Oils

2.1 Requirements and oil change intervals

Important

Dispose of used fluids and lubricants in accordance with local regulations.
Used oil must never be disposed of via the fuel tank!

Requirements for the approval of engine oils

The conditions for the approval of engine oils for diesel engines are specified in the delivery standard MTL 5044, which can be ordered under this reference number.

Manufacturers of engine oils are notified in writing if their product is approved.

Diesel engine oils approved for Series 1600 engines are divided into the following quality categories:

- Oil category 2: Higher quality oils / multi-grade oils
- Oil category 2.1: Multi-grade oils with a low ash-forming additive content (low SAPS oils)
- Oil category 3: Highest quality / Multi-grade oils
- Oil category 3.1: Multi-grade oils with a low ash-forming additive content (low SAPS oils)

Low SAPS oils are oils with a low sulfur and phosphor content and an ash-forming additive content of $\leq 1\%$. They are only approved if the sulfur content in the fuel does not exceed 50 mg/kg. Depending on the exhaust gas aftertreatment used, the use of low-ash oils is prescribed (→ Page 9).

Selection of a suitable engine oil is based on fuel quality, projected oil drain interval and on-site climatic conditions. At present there is no international industrial standard which alone takes into account all these criteria.

Important

The use of engine oils not approved by Rolls-Royce Solutions can result in increased wear and can mean that statutory emission limits can no longer be observed. This can be a punishable offense.

Special features of Rolls-Royce Solutions diesel engine oils

The following multi-grade oils are available depending on the relevant region.

Multi-grade oils from Rolls-Royce Solutions

Manufacturer & sales region	Product name	SAE grade	Oil category	Material no.
Rolls-Royce Solutions GmbH Europe Middle East Africa	Diesel Engine Oil DEO SAE 15W-40	15W-40	2	20 l canister: X00070830 210 l barrel: X00070832 IBC: X00070833 Loose items: X00070835 (only on request)
Rolls-Royce Solutions America Inc. Americas	Power Guard® SAE 15W-40 Off Highway Heavy Duty	15W-40	2.1	5 gallons: 800133 55 gallons: 800134 IBC: 800135
Rolls-Royce Solutions Asia Pte. Ltd. Asia	Diesel Engine Oil DEO SAE 15-W40	15W-40	2	18 l canister: 64247/P 200 l barrel: 65151/D

TIM-ID: 0000010717 - 007

Manufacturer & sales region	Product name	SAE grade	Oil category	Material no.
Rolls-Royce Solutions Suzhou Co. Ltd. China	Diesel Engine Oil - DEO 15W-40	15W-40	2	20 l canister: 64242/P 205 l barrel: 65151/D
	Diesel Engine Oil - DEO 10W-40	10W-40	2	20 l canister: 60606/P
	Diesel Engine Oil - DEO 5W-30	5W-30	3	20 l canister: 60808/P
Rolls-Royce Solutions Asia Pte. Ltd. Indonesia	Diesel Engine Oil - DEO 15W-40	15W-40	2	20 l canister: 64242/P 205 l barrel: 65151/D
mtu India Pvt. Ltd. India	Diesel Engine Oil - DEO 15W-40	15W-40	2	20 l canister: 63333/P 205 l barrel: 65151/P

Oil change interval

Important

The oil change interval is 1,000 operating hours or max. 1 year under the condition that engine oils of oil category 3 and 3.1 and approved fuels (→ Page 23) are used.

The oil change interval is 500 operating hours or max. 1 year under the condition that engine oils of oil category 2 and 2.1 and approved fuels (→ Page 23) are used.

If fuels which have not been approved are used, shorter oil change intervals are to be expected.

Prior to using non-approved fuels, contact Rolls-Royce Solutions to determine the applicable oil change intervals.

Important

Mixing different engine oils is strictly prohibited!

If, in exceptional cases, the engine oil filled in the engine is not available, top up with another mineral or synthetic engine oil. Ensure that it is approved for mtu products (→ Page 9).

Note the following:

- If you top up an engine oil of lower quality, the maintenance interval corresponding to the lower quality (oil category) must apply. The maintenance interval is reduced.
- If you use an engine with a higher quality, the maintenance interval remains as it is. Observe the specifications in the maintenance booklet.

Changing to another approved oil grade can be done together with an oil change. The remaining oil quantity in the engine oil system is not critical in this regard. This procedure also applies to the genuine Rolls-Royce Solutions engine oil grades in the regions Europe, Middle East, Africa, America and Asia.

Important

When changing to an engine oil of Category 3, note that the improved cleaning effect of these engine oils can result in the loosening of engine contaminants (e.g. carbon deposits).

It may be necessary therefore to reduce the oil change interval and oil filter service life (one time during change).

2.2 Viscosity grades

Selection of the viscosity grade is based primarily on the ambient temperature at which the engine is to be started and operated. Figure (→ Figure 1) contains guideline values for the temperature limits of the individual viscosity grades.

The temperature specifications of the SAE grade are always based on fresh oils. During operation, engine oil ages due to soot and fuel residue. This results in significant deterioration of the properties of the engine oil particularly at low outside temperatures. At outside temperatures below -20 °C, Rolls-Royce Solutions strongly recommends the use of engine oil of SAE grade 5W-30 or - if approved - 0W-30.

If the prevailing temperature is too low, the engine oil must be preheated.

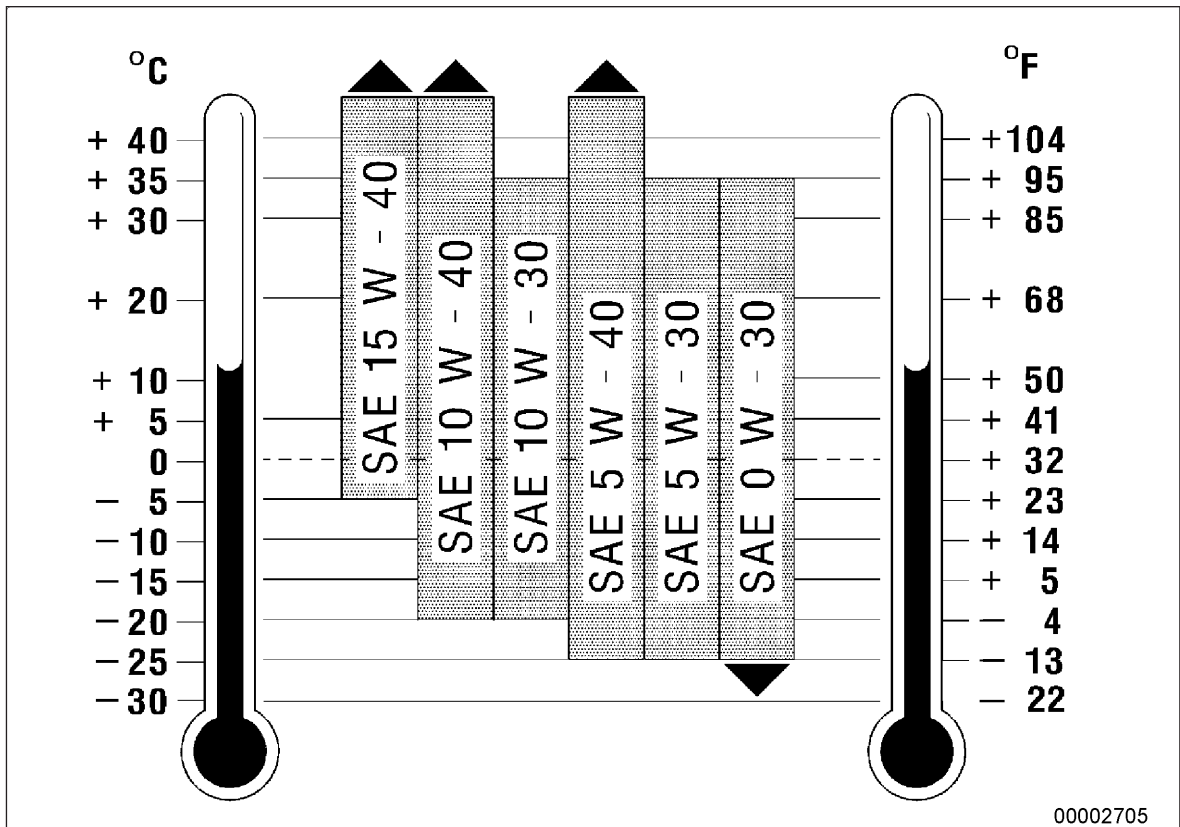

Figure 1: Viscosity grades

2.3 Series-dependent usability of engine oils

Series-dependent usability of engine oils by oil categories

Series	Approved engine oils	
	Oil categories 2 and 2.1 (Low SAPS)	Oil categories 3 and 3.1 (Low SAPS)
1600Gx0	<ul style="list-style-type: none">• Multi-grade oils (→ Page 41)• Multi-grade oils (Low SAPS) (→ Page 50)	<ul style="list-style-type: none">• Multi-grade oils (→ Page 54)• Multi-grade oils (Low SAPS) (→ Page 59)

2.4 Used-oil analysis

In order to check the used oil, it is recommended that regular oil analyses be carried out. Oil samples should be taken and analyzed at least once per year and during each oil change and under certain conditions, depending on application and the engine's operating conditions, sampling / analysis should take place more frequently.

The specified test methods and limit values (Analytical Limit Values for Used Diesel Engine Oils) (→ Table 2) indicate when the results of an individual oil sample analysis are to be regarded as abnormal.

An abnormal result requires immediate investigation and remedy of the abnormality.

The limit values relate to individual oil samples. When these limit values are reached or exceeded, an immediate oil change is necessary. The results of the oil analysis do not necessarily give an indication of the wear status of particular components.

In addition to the analytical limit values, the engine condition, its operating condition and any operational faults are decisive factors with regard to oil changes.

Some of the signs of oil deterioration are:

- Abnormally heavy deposits or precipitates in the engine or engine-mounted parts such as oil filters, centrifugal oil filters or separators, especially in comparison with the previous analysis.
- Abnormal discoloration of components.

Analytical limit values for used diesel engine oils

	Test method	Limit values	
Viscosity at 100 °C max. mm ² /s	ASTM D445 DIN 51562 DIN 51569-1	SAE 5W-30	15.0
		SAE 10W-30	
min. mm ² /s		SAE 5W-40	19.0
		SAE 10W-40	
		SAE 15W-40	
		SAE 20W-40	
		SAE 5W-30	9.0
		SAE 10W-30	
		SAE 5W-40	10.5
		SAE 10W-40	
		SAE 15W-40	
		SAE 20W-40	
Flashpoint °C (COC)	ASTM D92 DIN EN ISO 2592	Min. 190	
Flashpoint °C (PM)	ASTM D93 DIN EN ISO 2719	Min. 140	
Soot content (by weight %)	DIN 51452 CEC-L-82-97	Max. 3.5	
Total base number (mg KOH/g)	ASTM D2896 ISO 3771 DIN 51639	Min. 50% of new-oil value	
Proportion of water (vol. %)	ASTM D6304 EN 12937 ISO 6296	Max. 2000 mg/kg	
Oxidation (A/cm) ¹⁾	DIN 51453 ¹⁾	Max. 25	

	Test method	Limit values
Ethylene glycol (mg/kg)	ASTM D2982	max. difference between new-oil value and used-oil value 100
Additive element contents	DIN 5 1399-1 DIN 5 1399-2 ASTM D5158	To confirm that the new oil is identical with the oil grade of the used oils

Table 2:

¹⁾ = only possible if there are no ester compounds

2.5 mtu Advanced Fluid Management System for engine oils – Test package for North America

A sophisticated system for diagnostics and preventive maintenance is available in North America. This system allows the following:

- Optimized oil change intervals
- Extended engine service life
- Detection of minor problems before they become major problems
- Maximization of diesel engine-generator set's reliability
- Higher resale value of diesel engine-generator set

For full information on the mtu Advanced Fluid Management System available in North America, please contact an authorized Rolls-Royce Solutions service partner.

The following test packages from mtu Advanced Fluid Management System can be ordered from authorized Rolls-Royce Solutions service partners in North America:

- BMP32
Extended test – monitoring of wear and contamination
- AMP51R
Extended Test Plus – extension of the oil change intervals

The following engine oil parameters can be determined:

Engine oil parameters	BMP32	AMP51R
24 elementary metals *	✓	✓
percent water *	✓	✓
Viscosity at 40 °C for ISO engine oils	✓	✓
Viscosity at 100 °C for SAE engine oils	✓	✓
Percent fuel dilution **	✓	✓
Percent soot **	✓	✓
Oxidation/nitration	-	✓
Total base number **	-	✓
Total acid number	-	✓

* Samples of non-engine oils submitted with Order No. BMP32, are only examined spectrometrically for metals and the proportion of water and viscosity are determined.

** Samples of non-engine oils submitted with Order No. AMP51R are not examined for fuel dilution, soot content and base number.

The mtu Advanced Fluid Management System with trend analysis provides information for maximizing system reliability. The following guidelines must be followed to obtain the best results.

Samples must be taken:

- While the engine is operating under normal conditions or immediately after stopping the engine while the engine is still at operating temperature
- Every 250 hours at the same point
- By means of suction pump via dipstick tube or sampling cock in filter return

Note: The software offered by Rolls-Royce Solutions for online reporting with trend analyses shows the procedure for optimizing evaluation of the gathered information after completion of the analysis.

Note: The mtu Advanced Fluid Management System works together with independent test laboratories accredited according to ISO 17025 A2LA. This accreditation is the highest level of quality obtainable by a test laboratory in North America.

3 Coolants

3.1 Coolant – General

Definition of coolant

Coolant = coolant additive (concentrate) + freshwater to predefined mixing ratio
Ready for use in engine

Coolants must be prepared from suitable freshwater and a coolant additive approved by Rolls-Royce Solutions.

Important

Conditioning of the coolant takes place outside the engine.
Mixing of different coolant additives and supplementary additives is prohibited!

Important

Ready mixtures are coolants ready for direct use in the engine. They must not be diluted with freshwater.

Important

Flush with freshwater before changing from a silicon-containing antifreeze product (ready mixture or concentrate) to a silicon-free product! The same applies when changing from a silicon-free corrosion-inhibiting antifreeze to a product containing silicon.

The approval conditions for coolant additives are defined in the delivery standard MTL 5048 "Coolant Additives; Corrosion-inhibiting Antifreezes".

Emulsifiable corrosion inhibitor oils and water-soluble corrosion inhibitors are not permitted for Series 1600.

Coolant manufacturers are informed in writing if their product is approved.

Permissible application concentrations of engine coolants

Concentration for use	Coolant additive	Freshwater	Antifreeze protection ¹⁾ up to approx.
Minimum	40% by volume	60% by volume	-27 °C
	50% by volume	50% by volume	-37 °C
Maximum	55% by volume	45% by volume	-45 °C

Table 3:

¹⁾ = Antifreeze specifications determined as per ASTM D 1177

The coolant concentration used mainly depends on the antifreeze protection requirements.

Note:

The application concentration of a coolant or a ready mixture must be specified such that the share of coolant additives is always named first.

Example:

Coolant concentration 40% by volume = 40% by volume coolant additive + 60% by volume Freshwater

For ready mixtures, the proportion of coolant additive (concentrate) is always named first.

Example:

Power Cool®Universal 50/50 mix = 50% by volume coolant additive / 50% by volume Freshwater

Rolls-Royce Solutions engine coolant or coolant additives

The following engine coolants/coolant additives are available in the framework of mtu ValueCare.

Manufacturer & sales region	Product name	Type
Rolls-Royce Solutions GmbH, Rolls-Royce Solutions Asia Pte. Ltd. Europe Middle East Africa Asia	Coolant AH 100 Antifreeze Con- centrate	Antifreeze concentrate
	Coolant AH 50/50 Antifreeze Pre- mix	Antifreeze, ready mixture
	Coolant AH 40/60 Antifreeze Pre- mix	Antifreeze, ready mixture
Rolls-Royce Solutions America Inc. America	Power Cool®Universal 50/50 mix	Antifreeze, ready mixture

Table 4:

Avoiding damage in the coolant system

- When topping up (following loss of coolant) it must be ensured that not only water but also concentrate is added. The specified antifreeze and/or corrosion inhibitor concentration must be maintained.
- Flushing with water is required at every change to a different coolant product. See flushing and cleaning specifications for engine coolant circuits (→ Page 71).
- Do not exceed an antifreeze concentration of 55% by volume (max. antifreeze protection). Concentrations in excess of this reduce antifreeze protection and heat dissipation.
- The coolant must not contain any oil or copper residue (in solid or dissolved form).
- The corrosion-inhibiting effect of coolant is only ensured with the coolant circuit fully filled. Apart from that, only the corrosion inhibitors approved for internal preservation of the coolant circuit provide proper corrosion protection when the medium was drained. This means that after draining the coolant the cooling circuit must be preserved if no more coolant is to be filled. For the preservation procedure, refer to the Rolls-Royce Solutions Preservation and Represervation Specifications A001070/.. of the engine.
- A coolant circuit can usually not be drained completely, i.e. residual quantities of used coolant or freshwater from a flushing procedure remain in the engine. These residual quantities can result in the dilution of a coolant to be filled (mixed from a concentrate or use of a ready mixture). This dilution effect is higher the more add-on components there are on the engine. Check the coolant concentration in the coolant circuit and adapt it if necessary.

Important

All coolants approved in these Fluids and Lubricants Specifications generally relate only to the coolant circuit of mtu engines. In the case of complete drive systems, the fluids and lubricants approvals of the component manufacturer must be observed!

Important

For corrosion-related reasons, it is not permissible to operate an engine with pure water without the addition of an approved corrosion inhibitor!

3.2 Unsuitable materials in the coolant circuit

Components made of copper, zinc and brass materials

Unless various preconditions are observed, components made of copper, zinc and brass materials in the coolant circuit can cause an electrochemical reaction in conjunction with base metals (e.g. aluminum). As a result, components made of base metals are subject to corrosion or even corrosive pitting. The coolant circuit becomes leaky at these points.

Requirements

Based on current knowledge, the following materials and coatings must not be used in an engine coolant circuit because negative mutual reactions can occur even with approved coolant additives.

Metallic materials

- No galvanized surfaces
The entire cooling system must be free of zinc components. This also applies to coolant supply and drain lines as well as to storage containers
- Do not use components containing brass in the coolant circuit (e.g. coolers made of CuZn30) if exposed to ammoniacal solutions (e.g. amines, ammonium, ...) and solutions containing nitrite or sulfate. Stress-corrosion cracking is possible in the presence of tensile stress and a critical potential area. "Solutions" refer to cleaning agents, coolants and similar substances.
- Avoid copper materials wherever possible or keep their effective surface area to the bare minimum. Use coolants with purely organic inhibitors if copper alloys are involved. The coolant used must therefore only be marked with a cross in the "Organic" column in chapter 6.2 (→ Page 20).

Non-metallic materials

- Do not use EPDM or silicone elastomers if emulsifiable corrosion inhibitor oils are used or other oils are introduced to the coolant circuit.

Coolant filter / filter downstream of plant components

- If such filters are used, only products that do not contain additives may be used. Supplementary additives such as silicates, nitrites etc. can diminish the protective effect or service life of a coolant and, possibly, attack the materials installed in the coolant circuit.

Information:

Consult the relevant Rolls-Royce Solutions specialist department in case of doubt about the use of materials on the engine / externally mounted components in coolant circuits.

3.3 Requirements imposed on freshwater

Only clean, clear water with values in accordance with those in the following table must be used for preparing the coolant. If the limit values of the water are exceeded, demineralized water can be added to reduce the hardness or mineral content.

Freshwater requirements for coolant treatment

	Minimum	Maximum
Sum of alkaline earth metals *) (Water hardness)	0 mmol/l 0°d	2.7 mmol/l 15°d
pH value at 20 °C	5.5	8.0
Chloride ions + fluoride ions		100 mg/l
Sulfate ions		100 mg/l
Bacteria		10 ³ CFU (colony forming unit)/ml
Fungi, yeasts	are not permitted!	

*) Common designations for water hardness in various countries:

1 mmol/l = 5.6°d = 100 mg/kg CaCO₃

- 1°d = 17.9 mg/kg CaCO₃, USA hardness
- 1°d = 1.79° French hardness
- 1°d = 1.25° English hardness

3.4 Operational checks

Inspection of the freshwater and continuous monitoring of the coolant are essential for trouble-free engine operation. Freshwater and coolant should be checked at least once per year and with each fill-up. Inspections can be carried out using the mtu test kit, or by an authorized laboratory. The mtu test kit contains the necessary equipment, chemicals and instructions for use.

Minimum requirements and methodology for coolant monitoring

Analysis	Method for on-site checks (mtu test kit)	Method for lab analysis
Determination of the water hardness	Titration	Determination of the Ca and Mg content by means of ICP and calculation of the hardness in °dH or mmol/l
Determination of the pH value	Litmus paper strips for an appropriate measuring range	ASTM D 1287
Determination of the chloride content	Titration	IC
Determination of the sulfate content	-	IC
Determination of the silicon content	-	ICP
Determination of antifreeze concentration	Glycol refractometer, concentration in % by volume can be read off directly	Refractometer method DIN 5 1423, calculation through refraction index or product-specific factor

Table 5:

Orders for freshwater and coolant analysis may be placed with Rolls-Royce Solutions. In particular cases, operational monitoring can cover more checks than those listed in table (→ Table 5). Please contact your Rolls-Royce Solutions partner if necessary.

Coolant requirements

Value	Minimum	Maximum
pH value with antifreeze	7.5	9.0
Silicon (valid for coolants containing Si)	25 mg/l	

Table 6:

The coolant must be changed in case of non-compliance with the above specifications.

Note:

For a holistic appraisal of a coolant function, apart from the above-mentioned limit values the respective coolant-specific characteristic data and the fresh water quality used must be taken into consideration.

3.5 Storage capability of coolant concentrates

The storage capability specifications refer to coolant concentrates in original, hermetically sealed packing with storage temperatures up to max. 30 °C.

Storage capability

Coolant concentrate	Limit value	Brand name / Remarks
Antifreeze	Approx. 3 years	Observe manufacturer's specifications

Table 7:

Important
For reasons of corrosion protection, do not store in galvanized containers. Take this requirement into account when coolant must be transferred. Store containers in hermetically sealed condition in a cool and dry place. Ensure proper antifreeze protection during the cold season. Further information can be obtained from the product and safety data sheets for the individual coolants.

3.6 Color additives to detect leakage in the coolant circuit

The fluorescent dye listed below is approved as an additive for coolant without antifreeze and antifreeze to detect leakages.

¹⁾ = Based on original and hermetically sealed containers in frost-free storage (> 5 °C)

Approved color additives

Manufacturer	Product name	Material no.	Container size	Storage stability ¹⁾
Chromatech Inc. Chromatech Europe B.V.	D11014 Chromatint Uranine Conc	X00066947	20 kg	2 years

Table 8:

Application:

Add approx. 40 g of dye per 180 l of coolant.

This is a generous amount of dye which is not to be exceeded.

Fluorescence (yellow hue) is clearly visible in daylight. UV light with a wavelength of 365 nm can be used in darker rooms.

3.7 Series-dependent usability of coolant additives

Series	Coolant system containing light metal parts	Approval of water-soluble corrosion inhibitors
1600Gx0	Yes	Water-soluble corrosion inhibitors are not approved for this engine series

Table 9: Water-soluble corrosion inhibitors

Series	Coolant system containing light metal parts	Approved antifreeze
1600Gx0	Yes	<ul style="list-style-type: none"> • For concentrates based on ethylene glycol, see (→ Page 66) • For ready mixtures based on ethylene glycol, see (→ Page 69)

Table 10: Antifreeze

3.8 mtu Advanced Fluid Management System for coolant – Test package for North America

A sophisticated system for diagnostics and preventive maintenance is available in North America. This system allows the following:

- Optimization of the coolant change intervals
- Evaluation of metal migration
- Evaluation of the coolant's corrosive properties
- Detection of the causes of problems in the cooling system in connection with blown cylinder-head gaskets, electrical ground problems, localized overheating and contaminants within and outside the system

For full information on the mtu Advanced Fluid Management System available in North America, please contact an authorized Rolls-Royce Solutions service partner.

The following test packages from mtu Advanced Fluid Management System can be ordered from authorized Rolls-Royce Solutions service partners in North America:

- C-P92
Basic test – For monitoring the corrosivity of the coolant and for detecting metal migration
- C-P94
Extended test – Identification of the causes of leaks in the combustion system, grounding problems and contamination in the plant
- C-P93
Extended Test Plus – Monitoring of corrosivity and metal migration plus HPLC analysis and IC analysis for confirmation of the determined contamination of the corrosion inhibitor

The following coolant parameters can be determined:

Coolant parameters	C-P92	C-P94	C-P93
15 elementary metals	✓	✓	✓
Glycol percentage	✓	✓	✓
Freezing point	✓	✓	✓
Boiling point	✓	✓	✓
pH value	✓	✓	✓
Total hardness	✓	✓	✓
SCA number	✓	✓	✓
Nitrite	✓	✓	✓
Specific conductivity	✓	✓	✓
Carboxylic acid	✓	✓	✓
Sensory parameters (color, oil, fuel, magnetic precipitation, amagnetic precipitation, odor and foam)	✓	✓	✓
Contamination and corrosion inhibitor through IC (chloride, sulfate, nitrite, nitrate, phosphate and glycolate)	-	✓	✓
HPCL	-	-	✓

The mtu Advanced Fluid Management System with trend analysis provides information for maximizing system reliability. The following guidelines must be followed to obtain the best results.

Samples must be taken:

- While the engine is operating under normal conditions or immediately after stopping the engine while the engine is still at operating temperature
- Every 250 hours at the same point

Note: The software offered by Rolls-Royce Solutions for online reporting with trend analyses shows the procedure for optimizing evaluation of the gathered information after completion of the analysis.

Note: The mtu Advanced Fluid Management System works together with independent test laboratories accredited according to ISO 17025 A2LA. This accreditation is the highest level of quality obtainable by a test laboratory in North America.

4 Liquid Fuels

4.1 Diesel fuels – General information

Important

Dispose of used fluids and lubricants in accordance with local regulations.

Selecting a suitable diesel fuel

The quality of the fuel has an influence on the engine power, engine lifetime and exhaust gas emissions.

Important

Diesel fuels are not available worldwide in the quality required.
The fuel properties depend on many factors, in particular, region, time of year and storage.

Important

The use of non-approved fuels can result in

- significant deviations in engine performance and serious engine damage.
- failure to comply with statutory exhaust gas emissions.
- shorter oil change intervals.

Consult Rolls-Royce Solutions before using non-approved fuels and to agree the oil change intervals!

Important

Dispose of used fluids and lubricants in accordance with local regulations.

Unsuitable fuel usually leads to a reduced operational life of engine components and can also cause engine damage. Furthermore, there is a risk that the statutory exhaust gas emissions are no longer observed.

Further details on fuel qualities, tank care and filtration are available in the publication “Useful information on fuels, tank systems and filtration” (publication number A060631/..).

In order to achieve optimum engine performance and satisfactory service life for the entire fuel and injection system, the limit values for water, total contamination (undissolved solids content) and particle size distribution must be complied with in the vehicle tank for all approved fuel qualities.

Fuel specifications to be complied with

		Test method		Limit values
		ASTM		
Composition				The diesel fuel must be free of inorganic acids, visible water, solid foreign matter and chlorous compounds
Total contamination (= elements insoluble in fuel)	max.	D6217	EN 12662	24 mg/kg
Density at 15 °C	min.	D1298	EN ISO 3675	0.820 g/ml
	max.	D4052	EN ISO 12185	0.860 g/ml
API gravity at 60 °F	min.	D287		41
	max.			33
Viscosity at 40 °C	min.	D445	EN ISO 3104	1.5 mm ² /s
	max.			4.5 mm ² /s
Flashpoint (closed crucible)	min.	D93	EN ISO 2719	55 °C (60 °C for SOLAS) ¹⁾

		Test method		Limit values
		ASTM		
Boiling curve:		D86	EN ISO 3405	
- Initial boiling point				160 to 220 °C
- Volume share at 250 °C	max.			65% by volume
Recovery at 350 °C	min.			85% by volume
- Residue and loss	max.			3% by volume
Fatty acid methyl ester (FAME) content ("Biodiesel")	max.		EN 14078 Internal mtu procedure	7.0% by volume
Water content: (absolute, no free water)	max.	D6304	EN ISO 12937	200 mg/kg
Carbon residue from 10% distillation residue	max.	D189	EN ISO 10370	0.30% by weight
Oxide ash: ²⁾		D482	EN ISO 6245	
- Engines without exhaust gas after-treatment or recirculation	max.			0.01% by weight (100 mg/kg)
- Engines with exhaust gas after-treatment or recirculation	max.			0.001 % by weight (10 mg/kg)
Sulfur content: ²⁾		D5453, D2622	EN ISO 20846 EN ISO 20884	
- Engines without exhaust gas after-treatment or recirculation	max.			0.05% by weight (500 mg/kg) ²⁾
- Engines with exhaust gas after-treatment or recirculation	max.			0.0015% by weight (15 mg/kg)
Cetane number	min.	D613	EN ISO 5165, EN ISO 15195	45
	max.			78 ³⁾
Cetane index	min.	D976	EN ISO 4264	42
Copper corrosion 3 hrs. at 50 °C	Max. degree of corrosion	D130	EN ISO 2160	1 a
Oxidation stability (Rancimat)	min.		EN 15751	20 hours
Oxidation stability	max.	D2274	EN ISO 12205	25 g/m ³
Lubricity at 60 °C (HFRR value)	max.	D6079	EN ISO 12156-1	520 µm
Cold filter plugging point (CFPP)		D6371	DIN EN 116	See Note ⁴⁾
Particle distribution for fuel between last tank before engine and prefilter (see Fig. 4 item 6)		D7619	Coding of number of particles as per ISO 4406	Common rail: max. ISO Code 18/17/14 for 4/6/14 µm particle size
Cloud point		D2500	DIN EN 23015	See Note ⁵⁾
Neutralization number	max.	D974		0.2 mgKOH/g
Total aromatic compounds [% (M/M)]	max.		EN 12916 SIS 155116	37 ³⁾

Table 11:

¹⁾ For marine applications, a min. flashpoint of 60 °C (SOLAS = Safety of life at sea) applies.

²⁾ Note: 1 % by weight = 10000 mg/kg = 10000 ppm

³⁾ Limit value applies to 12V1600 Rx1 EUV only

⁴⁾ Filter plugging point or Cold Filter Plugging Point (CFPP) denotes the temperature at which a test filter is blocked under defined conditions by precipitated paraffins. This characteristic is used for diesel fuels as per DIN EN 590 to describe the climatic requirements (e.g. summer and winter diesel).

⁵⁾ The cloud point is the temperature at which a liquid product becomes turbid in the test glass due to precipitation of paraffin. This must not be higher than the ambient temperature.

It is the fuel supplier's responsibility to provide a fuel that will assure correct engine operation at the expected minimum temperatures and under the given geographical and other local conditions.

The operating company must ensure that there is always sufficient fuel to meet the corresponding climatic requirements.

Note:

For safe and efficient engine operation, the specified limit values, in particular for water, total contamination, must be observed for all permissible fuel grades at the interface marked in Fig. 4 item 6, at the latest.

For plants without a prefilter, this refers to the feed between the last tank and the scope of supply of Rolls-Royce Solutions. For the analysis of the fuel quality, an interface (sample extraction cock) must be provided for sample extraction during operation.

For existing plants without an accessible feed, a sample extraction point in the last tank before the scope of supply of Rolls-Royce Solutions is permissible.

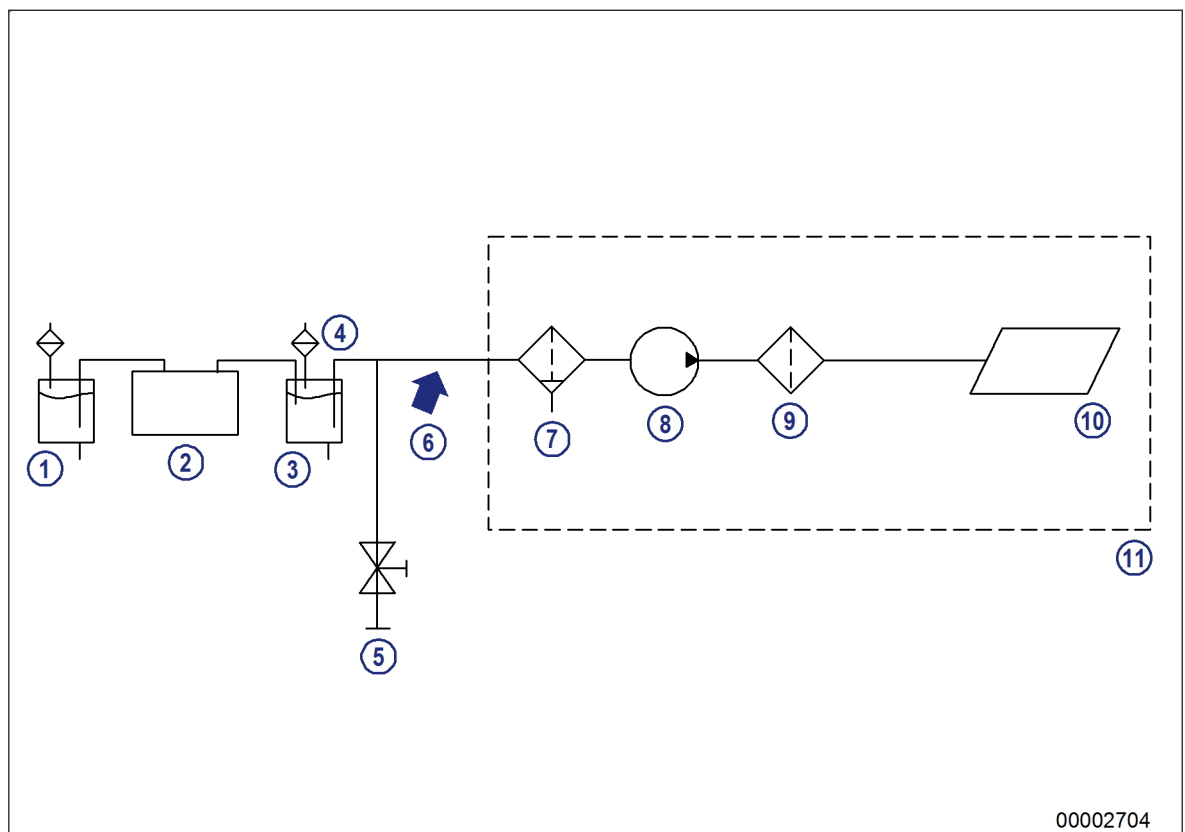

Figure 2: Fuel system diagram

- | | | |
|------------------------------|---------------------------------------|---------------------------|
| 1 Fuel tank | 5 Sample extraction
18/17/14 | 9 Main filter |
| 2 Fuel conditioning (option) | 6 Interface for fuel specification | 10 Injection system |
| 3 Last tank before engine | 7 Fuel prefilter with water separator | 11 Engine scope of supply |
| 4 Tank ventilation filter | 8 LP fuel pump | |

Note:

With poorer particle distribution, it is necessary to integrate further / more-optimized filter stages in the fuel system to achieve the operational life of fuel filters and components of the injection system.

For the limit values named for the interface, it has been validated that prefilters approved by Rolls-Royce Solutions provide sufficient filtration.

Warranty provided by Rolls-Royce Solutions shall not cover damage and harm to engines due to the use of fuel qualities not approved by Rolls-Royce Solutions.

Series-based injection / and exhaust aftertreatment systems

Overview of Series 1600 injection / and exhaust aftertreatment systems

Series	Diesel accumulator injection system (Common rail)	Exhaust aftertreatment system	Exhaust gas recirculation
1600 R70, R70L, R80, R80L	Yes	SCR	No
1600 R71, R71L, R81L, R91	Yes	DOC, DPF, SCR	No

Table 12:

Laboratory analysis

An order for fuel analysis can be placed with Rolls-Royce Solutions.

The following data is required:

- Fuel specifications
- Sampling point
- Sampling date
- Serial number of engine from which fuel sample was taken
- Laboratory examinations to be carried out
- Customer/contact person

Submit the following:

- 1 liter of fuel
- 2 liters of fuel (with additional determination of cetane number)

Winter operation

At low outdoor temperatures, the diesel fuel's fluidity can be inadequate on account of paraffin precipitation. In order to prevent operational problems (e.g. clogged filters) during the winter months, diesel fuel with suitable cold-flow characteristics should be used.

4.2 Biodiesel - biodiesel admixture

The standardized general term "FAME" (fatty acid methyl ester) is used here to designate biodiesel fuels.

General notes

- We can make no comment with regard to the level of FAME resistance of the fuel system, which is not part of our scope of supply.
- FAME is an extremely effective solvent. Any contact with paint, for example, must therefore be avoided.
- The characteristic smell of FAME exhaust, especially during long periods of idling, may be perceived as unpleasant. The nuisance caused by smell can be reduced by an oxidation catalyst which may be installed by the vehicle / equipment manufacturers at their own risk.

Important

Our company accepts no responsibility for and provides no warranty in respect of any fault or damage connected in any way with the use of FAME of a lower quality or resulting from noncompliance with our specifications on operation using FAME. All resultant irregularities and consequential damage lie outside our responsibility.

Important

Series 1600 engines are not approved for operation with 100% FAME according to DIN EN 14214:2019-05.

Important

Diesel fuel with a FAME content of max. 7% in according to DIN EN 590:2017-10 may be used. Such fuel may also be used in engines which have not been approved for operation with FAME, without affecting oil drain intervals.

For diesel fuels with a FAME content >7%, a customer-specific approval can be requested depending on the model type. For model type-based approvals, refer to chapter (→ Page 31). The use of diesel fuels with a FAME content >7% can result in changes to the maintenance and oil change intervals.

Engine oil and servicing

- A certain amount of fuel always finds its way into the engine oil via the pistons and cylinders. Its high boiling point means that FAME does not evaporate but remains in the engine oil in its entirety. Under certain conditions chemical reactions may take place between FAME and the engine oil. This can lead to engine damage.
- In case of FAME-diesel mixed operation, therefore, the change intervals for engine oil and oil filters must be reduced.

Engine standstill

- Prior to any extended period out of operation, the fuel system must be flushed out in order to prevent congestion. For flushing, the engine must be operated for at least 30 minutes on FAME-free diesel fuel.

Use of B20 fuels - only for R1600GX0 and V1600GX0

Information on the use of B20 fuels is provided in the publication A060632/...

4.3 Heating oil EL

Heating oil differs from diesel fuel mainly because of the following non-specified characteristics:

- Cetane number
- Sulfur content
- Oxidation stability
- Corrosion effect on copper
- Lubricity
- Low temperature behavior

If the heating requirements comply with the specifications of the diesel fuel DIN EN 590:2019-05 (summer and winter quality), there are no technical reasons why it can not be used in the diesel engine

4.4 Supplementary fuel additives

Supplementary fuel additives

The engines are designed such that satisfactory operation with normal, commercially available diesel fuels is ensured. Many of these fuels already contain performance-enhancing additives.

The additives are added by the supplier as the party responsible for product quality.

Biocides are an exception.

Important

Attention is drawn to the fact that the use of diesel fuels or additives other than those stipulated in these Fluids and Lubricants Specifications is always the responsibility of the operator.

Approved biocides

Biocides should have a pure hydrocarbon structure, i.e. should only consist of the following components:

- Carbon
- Hydrogen
- Oxygen
- Nitrogen

They must not contain inorganic substances because they can cause damage to the engine. The use of halogenated biocides is prohibited due to their effects on the engine system and the environment.

A release for biocides that meet the above requirements is possible upon request.

Manufacturer	Brand name	Concentration for use
ISP Biochema Schwaben GmbH Ashland Specialty Ingredients Luitpoldstrasse 32 87700 Memmingen Tel. +49 (0)8331 9580 0 Fax. +49 (0)8331 9580 51	Bakzid	100 ml / 100 l
Maintenance Technologies Paddy's Pad 1056 CC t/a Maintenance Technologies Tel. +27 21 786 4980 Cell +27 82 598 6830	Diesel Cure Fuel decontaminant	1 : 1200 (833 mg/kg)
Adolf Würth GmbH & Co. KG Reinhold Würth-Straße 12-17 74653 Künzelsau Tel. +49 (0)7940 15-2248	Diesel Cure Fuel decontaminant	1 : 1200 (833 mg/kg)
Vink Chemicals GmbH & Co.KG 21255 Kakenstorf Tel. +49 (0)4186 88797-0 Fax. +49 (0)418688797-10	grotamar 71 grotamar 82 StabiCor 71	0.5 l / ton 1.0 l / 1000 l 0.5 l / ton

Manufacturer	Brand name	Concentration for use
Supafuel Marketing CC PO Box 1167 Allens Nek 1737 Johannesburg South Africa Tel. +27 83 6010 846 Fax. +27 86 6357 577	Dieselfix / Supafuel	1:1200 (833 mg/kg)
Wilhelmsen Ships Service AS Willem Barentszstraat 50 3165 AB Rotterdam-Albrtand- swaard Tel. +31 10 487 7777 Fax. +31 10 487 7888 Netherlands	DieselPower Biocontrol	333 ml / ton

Table 13:

Flow improvers

Flow improvers can not prevent paraffin precipitation but they do influence the size of the crystals and thus allow the diesel fuel to pass through the filter.

The effectiveness of the flow improvers is not guaranteed for every fuel. Certainty is only assured after laboratory testing of the filtering capability. Required quantities and mixing procedures must be carried out according to the manufacturer's instructions.

4.5 Series-dependent approval of diesel fuel grades for mtu engines

Commercially available diesel fuels meeting the following specifications are approved for use:

Distillate fuels

DIN EN 590 and ASTM D975

Fuels Fuel specifications	Series 1600Gx0
DIN EN 590: 2017-10 <ul style="list-style-type: none"> • Summer and winter quality • Particle distribution for fuel between tank and filtration system: max. ISO Code 18/17/14 	Approved
ASTM D975-18a <ul style="list-style-type: none"> • Grade 1-D • S 15, S 500 and S 5000 • Water content: max. 200 mg/kg • Total contamination: max. 24 mg/kg • Particle distribution for fuel between tank and filtration system: max. ISO Code 18/17/14 	Approved for S 15 and S 500
ASTM D975-18a <ul style="list-style-type: none"> • Grade 2-D • S 15, S 500 and S 5000 • Water content: max. 200 mg/kg • Total contamination: max. 24 mg/kg • Particle distribution for fuel between tank and filtration system: max. ISO Code 18/17/14 	Approved for S 15 and S 500
Low-sulfur diesel fuels (Smax. 50 mg/kg) whose properties correspond to fuels in acc. with DIN EN 590 2014-04 <ul style="list-style-type: none"> • Particle distribution for fuel between tank and filtration system: max. ISO Code 18/17/14 	Approved

Table 14: Fuel specifications for diesel fuel: DIN EN 590, ASTM D975 and other low-sulfur diesel fuel qualities

Heating oil

Fuels	Series
Fuel specifications	1600Gx0
DIN 51603-1:2017-03, heating oil EL Standard <ul style="list-style-type: none"> • Cetane number min. 45 or cetane index min. 42 • Lubricity max. 520 µm • With exhaust gas aftertreatment: Sulfur content max. 15 mg/kg • Particle distribution for fuel between tank and filtration system: max. ISO Code 18/17/14 	Approved for non-emission-certified engines ¹⁾
DIN 51603-1:2017-03, heating oil EL low-sulfur <ul style="list-style-type: none"> • Cetane number min. 45 or cetane index min. 42 • Lubricity max. 520 µm • With exhaust gas aftertreatment: Sulfur content max. 15 mg/kg • Particle distribution for fuel between tank and filtration system: max. ISO Code 18/17/14 	Approved for non-emission-certified engines ¹⁾
DIN 51603-6:2017-03, heating oil EL alternative	Not approved

Table 15: Fuel specifications for heating oil

¹⁾ = The operating company is responsible for the correct tax-related treatment of the heating oil utilization as well as the certification for operation with heating oil.

Marine distillate fuels in accordance with ISO 8217:2017-03

Fuels	Series
Fuel specifications	1600Gx0
Marine distillate fuel in accordance with DIN ISO 8217:2017-03 <ul style="list-style-type: none"> • DMX, DMA and DMZ • Max. sulfur content 500 ppm • Water content: 200 mg/kg • Total contamination: max. 24 mg/kg • Particle distribution for fuel between tank and filtration system: max. ISO Code 18/17/14 • Lubricity at 60 °C max. 520 µm • Oxidation stability 25 [g/m³] • With exhaust gas aftertreatment: Sulfur content max. 15 mg/kg 	Not approved
Marine distillate fuel in accordance with DIN ISO 8217:2017-03, DMB	Not approved

Table 16: Fuel specifications for marine distillate fuels in accordance with ISO 8217:2017-03

Aviation turbine fuels

Fuels	Series
Fuel specifications	1600Gx0
F-34/F-35, JP-8 <ul style="list-style-type: none"> • Max. sulfur content 500 ppm • Water content: 200 mg/kg • Particle distribution for fuel between tank and filtration system: max. ISO Code 18/17/14 • Lubricity at 60 °C max. 520 µm • Oxidation stability max. 25 [g/m³] • Flashpoint min. 60 °C in acc. with SOLAS • Cetane number min. 45 • Viscosity 1.5 to 4.5 mm²/s at 40 °C • Carbon residue max. 0.3 [% by weight] • Oxide ash max. 0.01 [% by weight] 	Not approved
F-44, JP-5 <ul style="list-style-type: none"> • Max. sulfur content 500 ppm • Water content: 200 mg/kg • Total contamination max. 24 mg/kg • Particle distribution for fuel between tank and filtration system: max. ISO Code 18/17/14 • Lubricity at 60 °C max. 520 µm • Oxidation stability max. 25 [g/m³] • Flashpoint min. 60 °C in acc. with SOLAS • Cetane number min. 45 • Viscosity 1.5 to 4.5 mm²/s at 40 °C • Carbon residue max. 0.3 [% by weight] • Oxide ash max. 0.01 [% by weight] 	Not approved
F-63, in accordance with DCSEA 108/A <ul style="list-style-type: none"> • Max. sulfur content 500 ppm • Water content: 200 mg/kg • Total contamination max. 24 mg/kg • Particle distribution for fuel between tank and filtration system: max. ISO Code 18/17/14 • Lubricity at 60 °C max. 520 µm • Oxidation stability max. 25 [g/m³] • Flashpoint min. 60 °C in acc. with SOLAS • Cetane number min. 45 • Viscosity 1.5 to 4.5 mm²/s at 40 °C • Carbon residue max. 0.3 [% by weight] • Oxide ash max. 0.01 [% by weight] 	Not approved

Table 17: Fuel specifications for aviation turbine fuels

NATO diesel fuels

Diesel fuel NATO Code F-75

Fuels	Series
Fuel specifications	1600Gx0
NATO Code F-75, TL 9140-0003 <ul style="list-style-type: none"> • - max. sulfur content 500 mg/kg • - water content: max. 200 mg/kg • - total contamination max. 24 mg/kg • - particle distribution for fuel between tank and filter system: max. ISO Code 18/17/14 • - lubricity at 60 °C max. 460 µm • - oxidation stability max. 15 [g/m³] • - flashpoint min. 61 °C • - cetane number min. 50 	Not approved
NATO Code F-75, STANAG 1385 <ul style="list-style-type: none"> • - sulfur content max. 500 ppm • - water content: max. 200 mg/kg • - total contamination: max. 24 mg/kg • - particle distribution for fuel between tank and filter system: max. ISO Code 18/17/14 • - lubricity at 60 °C max. 520 µm • - oxidation stability max. 25 [g/m³] • - flashpoint min. 60 °C • 	Not approved

Table 18: Fuel specifications for diesel fuel NATO Code F-75

Diesel fuel NATO Code F-76

Fuels	Series
Fuel specifications	1600Gx0
NATO Code F-76, STANAG 1385, Edition 6 <ul style="list-style-type: none"> • - sulfur content max. 500 ppm • - water content: max. 200 mg/kg • - total contamination: max. 24 mg/kg • - particle distribution for fuel between tank and filter system: max. ISO Code 18/17/14 • - lubricity at 60 °C max. 520 µm • - oxidation stability max. 25 [g/m³] • - cetane number min. 45 	Not approved
NATO Code F-76, DEF-STAN 91-4, Issue 8 <ul style="list-style-type: none"> • - sulfur content max. 500 ppm • - water content: max. 200 mg/kg • - total contamination: max. 24 mg/kg • - particle distribution for fuel between tank and filter system: max. ISO Code 18/17/14 • - lubricity at 60 °C max. 520 µm • - oxidation stability max. 25 [g/m³] • - cetane number min. 45 	Not approved
NATO Code F-76, MIL-DTL-16884N <ul style="list-style-type: none"> • - sulfur content max. 500 ppm • - water content: max. 200 mg/kg • - total contamination: max. 24 mg/kg • - particle distribution for fuel between tank and filter system: max. ISO Code 18/17/14 • - lubricity at 60 °C max. 520 µm • - oxidation stability max. 25 [g/m³] • - cetane number min. 45 	Not approved

Table 19: Fuel specifications for diesel fuel NATO Code F-76

4.6 Unsuitable materials in the diesel fuel circuit

Components made of copper and zinc materials

Even small amounts of zinc, lead and copper may leave deposits in diesel fuel injection systems, particularly in modern, state-of-the-art injection systems. For this reason, levels of zinc, lead or copper in tanks, fuel lines and filter elements shall not exceed the manufacturer's validated specifications.

Avoid using materials containing these metals as this may initiate catalytic reactions in the fuel leading to undesirable deposits in the injection system.

Requirements

Based on current knowledge, the following materials and coatings must not be used in a diesel fuel circuit because negative mutual reactions can occur even with approved coolant additives.

Metallic materials

- Zinc, also as surface protection
- Zinc-based alloys
- Copper
- Copper-based alloys with the exception of CuNi10 and CuNi30 (e.g. seawater cooler)
- Tin, also as surface protection
- Magnesium-based alloys

Non-metallic materials

- Elastomers: Nitrile butadiene rubber, natural rubber, chloroprene rubber, butyl rubber, EPDM
- Silicone elastomer
- Fluorosilicone elastomer
- Polyurethane
- Polyvinyl

Information:

Consult the relevant Rolls-Royce Solutions specialist department in case of doubt about the use of materials on the engine / externally mounted components in fuel circuits.

4.7 Measures prior to engine out-of-service periods >1 month

General information

Diesel fuel according to EN 590 is currently permitted biodiesel shares of the 1st generation (FAME) of up to 7%. In case of long engine standstill, these biodiesel shares result in deposits. These deposits can cause problems when the engine is put back into operation; damage to components in the fuel circuit is possible.

To prevent deposits and resultant damage to the fuel system due to the 7% biodiesel share in the diesel fuel, the following measures are therefore required if the engine is to be taken out of service for a period of up to 6 months:

- The engine must be operated once a month for approx. 15 mins, at approx. 900 rpm with cut-in auxiliary consumers to reliably flush the fuel system.
- Prior to this, it is essential to check the perfect operation of the engine, in particular, with regard to the coolant and oil level. If the fuel systems have water separators, they must be drained prior to engine start. During engine start and engine operation, the operating parameters must be monitored carefully.
- Before putting engines that were placed in storage with B7 fuel back into operation, testing of the fuel is necessary to check its usability and quality (as per EN 590). If fuels do not comply with EN 590, they must be replaced.

Note:

Systems on the vehicle side with fuel supply can also be damaged due to deposits from the biodiesel shares. Adequate flushing is also required for these systems.

The monthly engine start can be omitted if the engine was flushed for at least 30 mins. prior to shutdown with FAME-free fuel (B0 fuel). For this purpose, the commercially available EN 590 fuel with 7% FAME is removed from the tank and then B0 fuel without FAME is filled. Ensure that all fuel-carrying parts of the engine system take part in the flushing procedure.

Fuels that currently meet the requirements of the die B0 specifications are, for example, ARAL Ultimate Diesel and BP Ultimate Diesel.

Note:

The bio share in the fuel is highly hygroscopic, which means that the bio share dehydrates the surrounding area and binds the water. This also results in an increased proportion of water in the tank during long out-of-service periods and the associated problems such as a coating formation, bacterial attack or corrosion which can cause damage to the vehicle/engine and fuel filtration system when the engine is put back into operation.

4.8 mtu Advanced Fluid Management System for fuels – Test package for North America

A sophisticated system for diagnostics and preventive maintenance is available in North America. This system allows the following:

For full information on the mtu Advanced Fluid Management System available in North America, please contact an authorized Rolls-Royce Solutions service partner.

The following test packages from mtu Advanced Fluid Management System can be ordered from authorized Rolls-Royce Solutions service partners in North America:

- F-PDFM1
Basic test – For checking the degree of contamination of the diesel fuel.
The test determines existing metallic elements and examines the proportion of water and contamination with bacteria and particles.
- F-PDFM2
Extended test – Includes the basic test plus an examination for determination of the degree of contamination, any possible filter contamination and ignition behavior of the engine.
- F-PDFM3
Extended Test Plus – Includes the extended text plus a lubricity analysis.
Maintenance of the correct lubricity has a positive effect on the service life of the components of the engine fuel system.

The following fuel parameters can be determined:

Fuel parameter	F-PDFM1	F-PDFM2	F-PDFM3
24 elementary metals	✓	✓	✓
Viscosity at 40 °C	-	✓	✓
Percent sulfur	-	✓	✓
Water and sediment	✓	✓	✓
Pour point	✓	✓	✓
Thermal stability	✓	✓	✓
Bacteria, fungi and mildew	✓	✓	✓
Flashpoint according to Pensky-Marten	-	✓	✓
Calculated centane index	-	✓	✓
Distillation	-	✓	✓
Cloud point	-	✓	✓
Percentage of water according to Karl Fischer	✓	✓	✓
Particle content	✓	✓	✓
Density according to API	-	✓	✓
Lubricity	-	-	✓

The mtu Advanced Fluid Management System with trend analysis provides information for maximizing system reliability. The following guidelines must be followed to obtain the best results.

Samples must be taken:

- While the engine is operating under normal conditions or immediately after stopping the engine while the engine is still at operating temperature
- Every 250 hours at the same point

Note: The software offered by Rolls-Royce Solutions for online reporting with trend analyses shows the procedure for optimizing evaluation of the gathered information after completion of the analysis.

Note: The mtu Advanced Fluid Management System works together with independent test laboratories accredited according to ISO 17025 A2LA. This accreditation is the highest level of quality obtainable by a test laboratory in North America.

5 NO_x Reducing Agent AUS 32 / AUS 40 for SCR Exhaust Gas Aftertreatment Systems

5.1 General information and storage

General information

SCR (Selective Catalytic Reduction) catalysts can be used for NO_x emission reduction. The reducing agent (aqueous urea solution (reducing agent with 32.5% urea share)) in such catalysts reduces the nitrogen oxide emissions.

In addition to ensuring compliance with exhaust emissions, reducing agents are used to safeguard the functionality of the exhaust gas aftertreatment system throughout its useful life. The reason for this is that the reducing agent is used to cool some of the component parts of the exhaust gas aftertreatment system (e.g. the reducing agent dosing units). Furthermore, some of the component parts of the exhaust gas aftertreatment system (e.g. the reducing agent supply units) may become clogged and damaged as a result of crystallization. Basically, the exhaust gas aftertreatment system may only be operated with a sufficient quantity of reducing agent filled in the reducing agent tank. To avoid damaging the system, only downtimes lasting less than < 24 h are acceptable from a technical point of view. Longer downtimes > 24 h without using reducing agent will damage the component parts of the exhaust gas aftertreatment system.

To ensure efficient operation of the exhaust gas aftertreatment system, compliance of the reducing agent with the quality requirements stipulated in DIN 70070 / ISO 222 41-1 is mandatory.

In Europe, this reducing agent is often offered under the brand name “AdBlue”.

The test methods to determine the quality and characteristics of the reducing agent are specified in the standards DIN 70071 / ISO 222 41-2.

Important

SCR systems from Rolls-Royce Solutions are designed for a concentration of 32.5% urea. The use of NO_x reducing agents with other concentrations of urea (AUS 40, AUS 48) is not approved!

Important

The use of antifreeze additives for AUS 32, or winter urea, is generally not approved.

Storage of reducing agent

For instructions on storage, packing and transport, refer to the ISO 222 41-3 standard . The instructions of the manufacturer must be observed.

The reducing agent crystallizes at -11 °C.

Avoid direct sunlight because it promotes the occurrence of microorganisms and the decomposition of the reducing agent.

6 Approved Engine Oils and Lubricating Greases

6.1 Multi-grade oils – Category 2 of SAE grades 10W-40, 15W-40 and 20W-40 for diesel engines

For details and special features, see chapter "Lubricants for four-cycle engines" (→ Page 6)

Multi-grade oils

Manufacturer	Brand name	SAE viscosity class	TBN			Remarks
			8 to 10 mgKOH/g	10 to 12 mgKOH/g	>12 mgKOH/g	
Rolls-Royce Solutions GmbH	Diesel Engine Oil DEO SAE 15W-40	15W-40		X		20 l container: X00070830 210 l container: X00070832 IBC: X00070833 Loose items: X00070835 (only on request)
Rolls-Royce Solutions Asia PTE. Ltd.	Diesel Engine Oil - DEO 15W-40	15W-40		X		20 l container: 64242/P 200 l container: 65151/D
Rolls-Royce Solutions Asia Pte. Ltd. China	Diesel Engine Oil - DEO SAE 15W-40	15W-40		X		20 l canister: 64242/P 205 l barrel: 65151/D
	Diesel Engine Oil - DEO SAE 10W-40	10W-40		X		20 l canister: 60606/P
mtu India Pvt. Ltd.	Diesel Engine Oil - DEO 15W-40	15W-40		X		20 l canister: 63333/P 205 l barrel: 65151/D Sale only intended in Indian market
Adnoc Distribution	Adnoc	15W-40		X		
Aegean Oil S.A.	Vigor Turbo SD 15W-40	15W-40	X			
Addinol Lube Oil	Addinol Super Longlife MD1047	10W-40		X		
	Addinol Diesel Longlife MD1548	15W-40		X		
Anomina Petroli Italiana	IP Tarus	15W-40	X			
	IP Tarus Turbo	15W-40	X			
	IP Tarus Turbo Plus	15W-40	X			
Arabi Enertech KSC	Burgan Ultra Diesel CH-4	15W-40		X		
Aral AG	Aral Turboral 10W-40	10W-40		X		
	Aral Turboral 15W-40	15W-40		X		
Atak Madeni Yag Lubricants	Alpet Turbot Fleetmax 1540	15W-40		X		
Auto-Teile-Ring GmbH	Cartechnic Motorenöl SAE 15W-40	15W-40	X			

Manufacturer	Brand name	SAE viscosity class	TBN			Remarks
			8 to 10 mgKOH/g	10 to 12 mgKOH/g	>12 mgKOH/g	
Avista Oil Refining & Trading Deutschland GmbH	Avista Advantage SHPD	15W-40	X			
	Avista Advantage UHPD	15W-40	X			
	Pennasol Turbo Super	15W-40		X		
	MOTOR GOLD Turbotec	15W-40		X		
Bahrain Petroleum Company B.S.C.	Frontier Megatek	10W-40	X			
	Frontier Super Plus	15W-40		X		
	Frontier Turbo	15W-40		X		
	Frontier Turbo LD	10W-40		X		
BayWa AG	Tectrol Turbo 4000	10W-40		X		
Belgin Madeni Yaglar	Lubex Marine M	15W-40		X		
BP p.l.c.	BP Vanellus C6 Global Plus	10W-40		X		
	BP Vanellus Multi-Fleet	15W-40			X	
	BP Multi Mine	15W-40	X			
	BP Mine Multi 15W-40	15W-40		X		
	BP Vanellus Longdrain	15W-40		X		
	BP Vanellus Multi A	10W-40		X		
	BP Vanellus Agri	10W-40		X		
	BP Vanellus Multi A	15W-40		X		
	BP Vanellus Agri	15W-40	X			
	BP Vanellus Max Extra	15W-40			X	
Castrol Ltd.	Castrol CRB Multi 10W-40 CI-4/E7	10W-40		X		
	Castrol CRB Multi 15W-40 CI-4/E7	15W-40		X		
	Castrol CRB Turbo 15W-40 CH-4/E7	15W-40	X			
	Castrol CRB Turbomax 15W-40 CI-4/SL/E7	15W-40		X		
	Castrol Rivermax CRB 15W-40 CI-4/E7	15W-40		X		
	Castrol Rivermax RX+ 15W-40	15W-40	X			
	Castrol Vecton 15W-40 DH-1	15W-40			X	
	Castrol RX Diesel	15W-40	X			
	Castrol RX Diesel 15W-40 CI-4/E7	15W-40		X		
	Castrol Vecton	10W-40		X		
	Castrol Vecton 15W-40 CI-4/E7	15W-40		X		
	Castrol Vecton 15W-40 CI-4/E7	15W-40			X	
	Castrol Vecton 15W-40 CI-4 Plus/SL/E7				X	
Cepsa	Cepsa Euromax SHPD	15W-40		X		

Manufacturer	Brand name	SAE viscosity class	TBN			Remarks
			8 to 10 mgKOH/g	10 to 12 mgKOH/g	>12 mgKOH/g	
Champion Chemicals N.V.	Champion New Energy	15W-40		X		
Chevron Lubricants (Caltex)	Delo SHP Multigrade	15W-40		X		
	Delo Gold Multigrade	15W-40	X			
	Delo Gold Ultra	15W-40		X		
	Delo Gold Ultra E	10W-40		X		
	Delo Gold Ultra E	15W-40	X			
	Delo 400 Multigrade	15W-40			X	
	OEC SAE 15W-40	15W-40		X		
Chevron Lubricants (Texaco)	Ursa Super TD	15W-40		X		
	Ursa Premium TDX	15W-40		X		
	Ursa Premium TDX Plus	15W-40		X		
	Ursa Heavy Duty	15W-40	X			
CPC Corporation, Taiwan	CPC Superfleet CG4 Motor Oil	15W-40	X			
Cubalub	Cubalub Extra Diesel MX	15W-40			X	
	Cubalub Extra Diesel	15W-40	X			
Cyclon Hellas	Cyclon D Super	15W-40	X			
Delek	Delkol Super Diesel	15W-40	X			
Delek Industries Ltd.	Super Diesel	15W-40		X		
Dunwell Petro-Chemical Co., Ltd.	Apex Super Motor Oil SL/CI-4, 15W-40	15W-40		X		
EKO A.B.E.E.	Eko Forza plus	15W-40	X			
Engen Petroleum Ltd.	Engen Dieselube 600 Super	15W-40	X			
	Engen Dieselube 700 Super	15W-40		X		
eni S.p.A.	Agip Blitum T	15W-40	X			
	eni i-Sigma super fleet	15W-40		X		
	eni i-Sigma performance E3	15W-40	X			
	eni i-Sigma performance E7	15W-40		X		
	eni i-Sigma performance E7	15W-40	X			
Exol Lubricants Ltd.	Taurus Extreme M	15W-40	X			
	Taurus Extreme HST	15W-40		X		

TIM-ID: 0000085107 - 005

Manufacturer	Brand name	SAE viscosity class	TBN			Remarks
			8 to 10 mgKOH/g	10 to 12 mgKOH/g	>12 mgKOH/g	
Exxon Mobil Corporation	Mobilgard 1 SHC	20W-40			X	
	Mobil Delvac Super 1300 C	15W-40	X			
	Mobil Delvac Super 1400	15W-40	X			
	Mobil Delvac MX	15W-40		X		
	Mobil Delvac MX Extra	15W-40		X		
	Mobil Delvac Advanced City Logistics	15W-40	X			
	Mobil Delvac Legend 15W-40 Flet CH-4	15W-40	X			
Finke Mineralölwerk GmbH	AVIATICON Turbo Super Plus	15W-40	X			
Fuchs Europe Schmierstoffe GmbH	Fuchs Titan Truck Plus	15W-40		X		
	Titan Unimax Ultra MC	10W-40		X		
	Titan Formel Plus	15W-40		X		
	Fuchs Titan Truck	15W-40	X			
	Titan Unimax Plus MC	10W-40		X		
	Fuchs Titan Universal HD	15W-40	X			
Fuchs Lubrifiants France	Cofran Plura Super	15W-40		X		
Fuchs Petrolub SE	Fuchs Max Way	15W-40		X		
	Fuchs Titan Truck Plus	10W-30		X		
	Fuchs Titan Truck Plus	15W-40		X		
Gazpromneft Lubricants Ltd.	G-Profi MSI 10W-40	10W-40		X		
	G-Profi MSI 15W-40	15W-40		X		
	G-Profi MSH 15W-40	15W-40		X		
	G-Profi MSI Plus	15W-40		X		
	Gazpromneft Diesel Premium	15W-40	X			
German Mirror Lubricants and Greases Co. FZE	Mirr Turbo Plus Diesel Engine Oil API CI-4 SAE 10W-40	10W-40		X		
	Mirr Turbo Plus Diesel Engine Oil API CI-4 SAE 15W-40	15W-40	X			
	Mirr Turbo Diesel Engine Oil API CH-4 SAE 15W-40	15W-40	X			
Ginouves Georges SAS	York 849	15W-40		X		
GS Caltex India Private Limited	Kixx Dynamic Gold	15W-40		X		
GS Caltex Corporation	Kixx HD 1	10W-40		X		
	Kixx HD 1	15W-40		X		

Manufacturer	Brand name	SAE viscosity class	TBN			Remarks
			8 to 10 mgKOH/g	10 to 12 mgKOH/g	>12 mgKOH/g	
Gulf Oil International	Gulf Super Duty VLE	15W-40	X			
	Gulf Superfleet LE	10W-40		X		
	Gulf Superfleet LE	15W-40	X			
	Gulf Superfleet Supreme	10W-40		X		
	Gulf Superfleet Supreme	15W-40		X		
	Gulf Superfleet Plus	15W-40	X			
Gulf Western Oil, Australia	TOP DOG XDO	15W-40	X			
HAFA France	Stradex 1800	10W-40		X		
Hessol Lubrication GmbH	Hessol Turbo Diesel	15W-40		X		
	Hessol Super Longlife	10W-40		X		
High Industrial Lubricants & Liquids Corporation (HILL)	Fastroil Force F300 Diesel	15W-40		X		
	Fastroil Force F500 Diesel	15W-40		X		
	Fastroil Force F700 Diesel Pro	10W-40		X		
Hitachi Construction Machinery CO., Ltd.	Hitachi Premium Orange	15-W40	X			
Huiles Berliet S.A.	RTO Maxima RD	15W-40	X			
	RTO Maxima RLD	15W-40		X		
Hyrax Oil	Hyrax Admiral 15W-40	15W-40	X			
INA Maziva Ltd.	INA Super Max	15W-40		X		
Indian Oil Corporation	Servo Premium (N)	15W-40		X		
Ipiranga Produtos des Petróleo S.A.	Ipiranga Brutus Alta Performance	15W-40		X		
Kuwait National Lube Oil MfgCo (KNLOC)	Burgan Ultra Diesel CH-4	15W-40		X		
Kuwait Petroleum	Q8 T 750	15W-40	X			
	Q8 T 800	10W-40	X			
Kocak Petrol Ürünleri San	Speedol SHPD Tirot 15W-40	15W-40		X		
Liqui Moly	Liqui Moly Marine 4T Motor Oil	15W-40		X		
	Liqui Moly Touring High Tech SHPD	15W-40	X			
Lotos Oil	Turdus Powertec CI-4 15W-40	15W-40		X		
	Turdus Powertec 1000	15W-40		X		
LPC S.A.	Cyclon Granit Maximum	15W-40		X		
Lubricantes de América	Generac Aceite	15W-40		X		
	Lubral Nano Diesel	15W-40		X		
Lubrisa	Gulf Superfleet Supreme	15W-40		X		

Manufacturer	Brand name	SAE viscosity class	TBN			Remarks
			8 to 10 mgKOH/g	10 to 12 mgKOH/g	>12 mgKOH/g	
Lukoil Lubricants Europe Oy	Teboil Power Plus	15W-40	X			
	Tepoil Super HPD	15W-40		X		
	Tepoil Super HPD C	10W-40		X		
Mabanol GmbH & Co. KG	Mabanol Argon Fleet	15W-40	X			
Mega Lube Marketers cc.	Megalube Diesel Engine Oil	15W-40		X		
Meguín GmbH	megol Motorenoel SHPD	15W-40	X			
Modriča Oil Refinery	Maxima Turbo	15W-40		X		
MOL-LUB Kft..	MOL Dynamic MK9	15W-40		X		
	MOL Mk-9	15W-40		X		
	Mol Dynamic Super Diesel	15W-40	X			
	Mol Dynamic Transit	10W-40		X		
	Mol Dynamic Transit	15W-40		X		
	MOL Super Diesel	15W-40	X			
Morris Lubricants Limited	Versimax HD4	15W-40		X		
Motorex AG	Motorex Universal	10W-40		X		
Motor Oil, Hellas	EMO SHPD Plus	15W-40		X		
MPM International Oil Company B.V.	Motor Oil 15W-40 Super High Performance	15W-40		X		
NetLube Iran	Max Turbo	15W-40		X		
NSL OilChem Trading Pte Ltd	Liquid Gold D-Flo X4	15W-40		X		
Oman Oil Marketing Company SAOG	Omanoil Maximo Super 15W40 CH-4	15W-40	X			
Orlen Oil	Mogul Diesel DTT Extra	15W-40			X	
	Platinum Ultor	15W-40	X			
	Platinum Ultor Plus	15W-40			X	
OOO "LLK-International"	Lukoil Avantgarde Extra	15W-40	X			
	Lukoil Avantgarde Ultra	15W-40		X		
	Lukoil Avantgarde NP	15W-40		X		
	Lukoil Avantgarde Ultra Plus	10W-40		X		
Oryx Energies	Enduro 600	15W-40		X		
Panolin AG	Panolin Universal SFE	10W-40		X		
	Panolin Diesel Synth	10W-40		X		
PDVSA CA	PDV Ultradiesel	15W-40		X		
Petrobras Colombia Combustibles	Petrobras Top Turbo T2	15W-40	X			
Petrobras Distribuidora S.A.	Lubrax Nautica Diesel	15W-40		X		

Manufacturer	Brand name	SAE viscosity class	TBN			Remarks
			8 to 10 mgKOH/g	10 to 12 mgKOH/g	>12 mgKOH/g	
Petro-Canada Lubricants	Duron	15W-40	X			
	Duron XL	15W-40	X			
Petrogulf Oil Manufacturing LLC	Paramount Extreme Action 15W40 CI-4	15W-40	X			
Petrogal, S.A.	Galp Galaxia LD star	15W-40	X			
Petron Corporation	Petron Rev-x Premium Multi Grade	15W-40	X			
Petronas Lubricants International	Petronas Urania 3000	15W-40	X			
	Petronas Urania LD7	15W-40	X			
	Petronas Urania LD 7	10W-40	X			
	Petronas Urania Supremo CI-4	10W-40	X			
	Petronas Urania Supremo CI-4	15W-40	X			
Petromin Corporation	Petromin Turbomaster XD	15W-40	X			
	Petromin Turbomaster XD 15W40 CI-4	15W-40	X			
Phillips 66 Lubricants	Conoco Hydroclear Power D	15W-40		X		
Prista Oil Holding EAD	Prista Turbo Diesel	15W-40	X			
	Pro Auto HDEO E7 15W-40	15W-40	X			
PT Pertamina Lubricants	Meditran SX	15W-40	X			
	Meditran SX Plus	15W-40	X			
PTT Public Limited	Navita Plus SAE 15W-40	15W-40	X			
Qatar Lubricants Company Ltd.	QALCO Topaz HMF	15W-40	X			
Qingdao Copton Technology Co., LTD.	Copton CH-4 Diesel Engine Oil	15W-40	X			
Raloy Lubricantes, S.S. de C.V.	Raloy Diesel Power	15W-40	X			
Raj Petro Specialities P Ltd.	Zoomol Rforce 3100 RF1	15W-40	X			
	Zoomol Rforce 3100 RF4	15W-40	X			
Ravensberger Schmierstoffvertrieb GmbH	RAVENOL Expert SHPD	10W-40	X			
	RAVENOL Mineralöl Turbo Plus SHPD	15W-40	X			
Repsol Lubricantes y Especialidades, S.A.	Repsol Diesel Super Turbo SHPD	15W-40	X			
	Repsol Neptuno S-Turbomar	15W-40	X			
RN-Lubricants, LLC	Rosneft Revolux D2	15W-40	X			
	Rosneft Revolux D3	15W-40	X			
	Rosneft Revolux D5	15W-40	X			
ROWE Mineralölwerk GmbH	ROWE Hightec Formula GT SAE 10W-40 HC	10W-40	X			
S.A.E.L.	Gulf Gulfleet Long Road	15W-40	X			

TIM-ID: 0000085107 - 005

Manufacturer	Brand name	SAE viscosity class	TBN			Remarks
			8 to 10 mgKOH/g	10 to 12 mgKOH/g	>12 mgKOH/g	
Shell International Petroleum Company	Shell Rimula MV	15W-40	X			
	Shell Rimula R3 MV	15W-40	X			
	Shell Rimula R3 X	15W-40		X		
	Shell Rimula R4	15W-40		X		
	Shell Rimula R4 X	15W-40		X		
	Shell Rimula RT4	15W-40		X		
	Shell Rimula RT4 X	15W-40		X		
	Shell Rimula T3	15W-40		X		
	Shell Rimula T4	15W-40		X		
	Shell Rimula X	15W-40		X		
	Shell Rotella T2	15W-40		X		
	Shell Rotella T Multigrade	15W-40		X		
	Shell Sirius S4	15W-40		X		
	Eicher Premium Plus Diesel Engine Oil	15W-40		X		
Shanghai HIRI Lubricants R & D Centre	HIRI	15W-40	X			
Singapore Petroleum Company Limited	SDM 900 SAE 15W40	15W-40		X		
Sinopec Lubricant Co., Ltd.	Sinopec Tulux T500	15W-40		X		
SK Lubricants Co. Ltd.	ZIC X5000 10W-40	10W-40		X		
	ZIC X5000	15W-40	X			
	ZIC X7000 CI-4 10W-40	10W-40		X		
	ZIC X7000 CI-4	15W-40	X			
SRS Schmierstoff Vertrieb GmbH	SRS Motorenöl O-236	15W-40	X			Erhöhter Korrosionsschutz
	SRS Multi-Rekord top	15W-40		X		
	SRS Multi Rekord plus	15W-40	X			
	SRS Turbo Rekord	15W-40	X			
	SRS Cargolub TFX	10W-40		X		
Tesla Technoproducts FZE	Denebola Saheli Ultra XS 1120	15W-40		X		
Top 1 Oil Products Company	Top 1 Transport	15W-40		X		

Manufacturer	Brand name	SAE viscosity class	TBN			Remarks
			8 to 10 mgKOH/g	10 to 12 mgKOH/g	>12 mgKOH/g	
Total Lubrifiants	Total Caprano Energy FE	15W-30		X		
	Total Caprano TDH	15W-40		X		
	Total Caprano TDI	15W-40		X		
	Total Disola W	15W-40		X		
	Total Genlub TDX	15W-40	X			
	Total Rubia TIR 6400	15W-40	X			
	Total Rubia Works 1000	15W-40		X		
	Hitachi Genuine Engine Oil 15W40 DH-1	15W-40		X		
Unil Opal	Medos 700	15W-40	X			
Valvoline EMEA	All-Fleet Extra SAE 15W-40	15W-40	X			
	All-Fleet Plus	15W-40	X			
	NextGen All-Fleet extra	15W-40		X		
	Premium Blue Classic	15W-40		X		
	Valvoline Premium Blue 7800	15W-40		X		
Viscolube	Revivoil - Re Refined High-Tech HD Motoroil	15W-40	X			
Viva Energy Australia	Penske Power Systems Premium	15W-40	X			
Wolf Oil Corporation NV.	Wolf Vitaltech 15W40	15W-40		X		
Wunsch Öle GmbH	Wunsch Rekord TLM-TU 10W-40	10W-40		X		

Table 20:

6.2 Multi-grade oils – Category 2.1 (Low SAPS oils), SAE grades 0W-30, 10W-30, 5W-40, 10W-40 and 15W-40

For details and special features, see chapter "Lubricants for four-cycle engines" (→ Page 6)

Multi-grade oils

Manufacturer	Brand name	SAE viscosity class	TBN			Remarks
			8 to 10 mgKOH/g	10 to 12 mgKOH/g	>12 mgKOH/g	
Rolls-Royce Solutions America Inc.	Power Guard® SAE 15W-40 Off-Highway Heavy Duty	15W-40	X			5 gallons: 800133 55 gallons: 800134 IBC: 800135 Available through Rolls-Royce Solutions America Inc.
Advanced Lubrication Specialties, Inc.	Advantage Premium Plus	15W-40		X		
	Advantage Ultra Premium Plus	5W-40		X		
BP p.l.c.	BP Vanellus Eco	15W-40	X			
Canroyal Oil Lubricants / Dist.	Canroyal Synthetic Diesel Engine Oil	15W-40	X			
Castrol Ltd.	Castrol CRB Mining 15W-40	15W-40	X			
	Castrol CRB Mining 15W-40 CK-4		X			
	Castrol CRB Turbo G4 15W-40	15W-40	X			
	Castrol Hypuron	10W-30		X		
	Castrol RX Super 15W-40 CJ-4/E9	15W-40	X			
Champion Chemicals N.V.	Champion OEM Specific 15W40 MS	15W-40	X			
Chevron Lubricants (Chevron)	Delo 400 LE	15W-40	X			
	Delo 400 MGX	15W-40	X			
	Delo 400 SDE	15W-40	X			
	Delo 400 XLE	10W-30		X		
	Delo 400 XLE	15W-40		X		
Chevron Lubricants (Texaco)	Ursa Ultra LE	15W-40	X			
ExxonMobil Corporation	Mobil Delvac 1 ESP	0W-40	X			
	Mobil Delvac 1 ESP	5W-40		X		
	Mobil Delvac 1300 Super F2	15W-40	X			
	Mobil Fleet 15W-40	15W-40	X			
eni S.P.A.	eni i-Sigma top MS	15W-40	X			
Finke Mineralölwerk GmbH	AVIATICON Turbo Premium ECO LA 10W-30	10W-30	X			
Fuchs Europe	Fuchs Titan Cargo	15W-40	X			

Manufacturer	Brand name	SAE viscosity class	TBN			Remarks
			8 to 10 mgKOH/g	10 to 12 mgKOH/g	>12 mgKOH/g	
Fuchs Petrolub SE	Fuchs Titan Cargo	10W-30	X			
	Fuchs Titan Cargo	15W-40	X			
Gulf Oil International	Gulf Supreme Duty XLE	15W-40	X			
	Gulf Supreme Duty XLE	10W-30	X			
Hitachi	Hitachi Genuine Engine Oil 10W-40 DH-2	10W-40	X			
Kuwait Petroleum	Q8 T 760	10W-30	X			
Lotos Oil	Turdus Powertec 1100	15W-40	X			
Morris Lubricants	Versimax HD6	15W-40	X			
Motorex AG	Motorex Focus CF	15W-40	X			
MPM International Oil Company B.V.	Motor Oil 15W-40 Extra High Performance	15W-40	X			
Neste Markkinointi Oy Lubricants	Neste Turbo+ NEX 10W-40	10W-40	X			
OOO "LLK-International"	Lukoil Avantgarde Professional LA	10W-30	X			
	Lukoil Avantgarde Professional LA	10W-40	X			
	Lukoil Avantgarde Professional LA	15W-40	X			
Panolin AG	Panolin Universal LA-X	15W-40	X			
Pennzoil Products	Pennzoil Long-Life Gold	15W-40		X		
Petro-Canada	Duron -E	15W-40	X			
Phillips 66 Lubricants	Fleet Supreme EC	15W-40	X			
	Guardol ECT	15W-40	X			
	Kenndall Super-D XA	15W-40	X			
Prolube Lubricants	Prolube Ultraplus	15W-40	X			
Repsol Lubricantes Y Especialidades, S.A.	Repsol Diesel Turbo THPD Mid Saps	15W-40	X			

Manufacturer	Brand name	SAE viscosity class	TBN			Remarks
			8 to 10 mgKOH/g	10 to 12 mgKOH/g	>12 mgKOH/g	
Shell International Petroleum Company	Shell Rimula Super	15W-40		X		
	Shell Rimula RT4L	15W-40		X		
	Shell Rotella T	15W-40		X		
	Shell Rotella T3	15W-40		X		
	Shell Rotella T3 Fleet	15W-40	X			
	Shell Rotella T5	10W-30	X			
	Shell Rotella T5	10W-40	X			
	Shell Rotella T6	5W-40		X		
	Shell Rimula R5 LE	10W-30	X			
	Shell Rimula R5 LE	10W-40	X			
	Shell Rotella T Triple Protection	15W-40		X		
	Shell Rimula R4 MV	15W-40	X			
	Shell Rimula R4 L	15W-40	X			
	Shell Sirius S4 L	15W-40	X			
SRS Schmierstoff Vertrieb GmbH	SRS Turbo Rekord plus	15W-40	X			
	SRS Turbo Rekord plus FE	10W-40	X			
Sunoco Lubricants	Super C	15W-40		X		
	Super C Gold	15W-40		X		
	Super C Gold Elite	5W-40		X		
The United Oil Company	Duralene Dura-Max 15W-40	15W-40		X		
	Duralene Dura-Syn HD	5W-40		X		
Total Lubrifiants	Hitachi Genuine Engine Oil 10W-40 DH-2	10W-40	X			
	Total Rubia TIR 7900	15W-40	X			
	Total Rubia Works 2000	10W-40	X			
	Total Star Max FE	10W-30	X			
	Total Rubia Works 2000 FE 10W-30	10W-30	X			
Trinidad & Tobago National Petroleum Marketing Company Ltd. (NPMC)	Ultra Duty 15W-40 Engine Oil	15W-40	X			
Valvoline Europe	All Fleet Superior LE-X SAE 10W-40	10W-40	X			
	All Fleet Extra SAE LE 15W-40	15W-40	X			
Valvoline EMEA	Valvoline All Fleet Extra LE SAE	15W-40	X			
	All-Fleet Extra LE NTI	15W-40	X			
	Premium Blue 8100 15W-40	15W-40	X			

TIM-ID: 0000085108 - 005

Manufacturer	Brand name	SAE viscosity class	TBN			Remarks
			8 to 10 mgKOH/g	10 to 12 mgKOH/g	>12 mgKOH/g	
Valvoline USA	All Fleet Plus	15W-40	X			
Verco International	April Superpro RXL 1 Gold Plus	15W-40	X			

Table 21:

6.3 Multi-grade oils – Category 3, SAE grades 5W-30, 5W-40, 10W-40 and 15W-40 for diesel engines

For details and special features, see chapter “Lubricants for four-stroke cycle engines” (→ Page 6)

Multi-grade oils

Multi-grade oils – Category 3, SAE grades 5W-30, 5W-40, 10W-40 and 15W-40 for diesel engines						
Manufacturer	Brand name	SAE viscosity class	TBN			Remarks
			8 to 10 mgKOH/g	10 to 12 mgKOH/g	>12 mgKOH/g	
Addinol Lube Oil GmbH	Addinol Commercial 1040 E4	10W-40		X		
	Addinol Ultra Truck MD 0538	5W-30			X	
	Addinol Super Truck MD 1049	10W-40			X	
Aral AG	Aral Mega Turboral	10W-40			X	
	Aral Mega Turboral 10W-40	10W-40			X	
	Aral Super Turboral	5W-30			X	
	Aral Super Turboral 5W-30	5W-30			X	
Aramco Lubricants and Retail Company	Orizon HD vA	10W-40		X		
Atak Madeni Yağ Pas.San. Tic. Aş	Alpet Turbot FE	10W-40			X	
	Alpet Turbot MMS	10W-40			X	
Avia AG	Avia Turbosynth HT-E	10W-40			X	
	Avia Turbosynth HT-U	5W-30			X	
Avista Oil Deutschland GmbH	Avista pure EVO E4	10W-40			X	
	Avista pure EVO SWE	5W-30			X	
	Avista pure EVO SWE	10W-40			X	
Bahrain Petroleum Company B.S.C.	Frontier Turbo LDX	10W-40			X	
BayWa AG	Tectrol Super Truck 530	5W-30			X	
	Tectrol Super Truck 1040	10W-40		X		
BP p.l.c.	BP Energol IC-MT 10W-40	10W-40			X	
	BP Vanellus Max	5W-30			X	

Multi-grade oils – Category 3, SAE grades 5W-30, 5W-40, 10W-40 and 15W-40 for diesel engines

Manufacturer	Brand name	SAE viscosity class	TBN			Remarks
			8 to 10 mgKOH/g	10 to 12 mgKOH/g	>12 mgKOH/g	
Castrol Ltd.	Castrol CRB Turbomax 10W-40 E4/E7	10W-40			X	
	Castrol Enduron MT	10W-40			X	
	Castrol Enduron Plus	5W-30			X	
	Castrol Elixion HD	5W-30			X	
	Castrol Vecton 10W-40 E4/E7	10W-40			X	
	Castrol Vecton Long Drain	10W-40			X	
	Castrol Vecton Long Drain 5W-30 E4/E7	5W-30			X	
	Castrol Vecton Long Drain 10W-40 E7				X	
	Castrol Vecton Long Drain 10W-40 E4/E7	10W-40			X	
	Castrol Vecton 5W-30 Arctic	5W-30			X	
	Castrol Vecton Fuel Saver 5W-30	5W-30			X	
	Castrol Vecton Fuel Saver E7	5W-30			X	
Cepsa	Cepsa Eurotrans SHPD	5W-30			X	
	Cepsa Eurotrans SHPD	10W-40		X		
Cepsa Comercial Petroleo Limited	Traction Advanced LD	10W-40			X	
Champion Chemicals N.V.	Champion New Energy 10W40 Ultra	10W-40			X	
Chemcis Khavremianeh Kohan	Chemcis Excel Plus	10W-40			X	
Chevron Lubricants (Caltex)	Delo Gold Ultra T SAE 10W-40	10W-40			X	
	Delo XLD Multigrade	10W-40			X	
Chevron Lubricants (Texaco)	Ursa HD	10W-40			X	
	Ursa Premium FE	5W-30			X	
	Ursa Super	10W-40		X		
	Ursa Super TDX	10W-40			X	
	Ursa TDX	10W-40			X	
Deutsche Ölwerke Lubmin GmbH	AVENO HC PT Diesel	10W-40			X	
eni S.P.A.	eni i-Sigma top	10W-40			X	
	eni i-Sigma performance E4	10W-40			X	
Enoc Marketing LLC	Enoc Vulcan 770 SLD	10W-40		X		
	Enoc Vulcan SLD	10W-40			X	

TIM-ID: 0000019006 - 009

Multi-grade oils – Category 3, SAE grades 5W-30, 5W-40, 10W-40 and 15W-40 for diesel engines

Manufacturer	Brand name	SAE viscosity class	TBN			Remarks
			8 to 10 mgKOH/g	10 to 12 mgKOH/g	>12 mgKOH/g	
Exxon Mobil Corporation	Mobil Delvac XHP Extra	10W-40			X	
	Mobil Delvac XHP Ultra 5W-30	5W-30			X	
	Mobil Delvac 1 SHC	5W-40			X	
	Mobil Delvac 1 SHC 5W-40	5W-40			X	
Exol Lubricants Ltd.	Taurus Extreme M3	10W-40			X	
Fabrika Maziva, FAM AD	Fenix Ultra Sint	10W-40			X	
Finke Mineralölwerk GmbH	AVIATICON Finko Truck LD	10W-40			X	
Fuchs Petrolub SE	Fuchs Titan Cargo SL	5W-30			X	
	Fuchs Titan Cargo MC	10W-40			X	
	Fuchs Max Way E4	10W-40				
	Fuchs Max Way Ultra	5W-30				
Fuchs Lubricants France S.A.	Cofran Marathon	10W-40			X	
Gazpromneft Lubricants Ltd,	G-Profi GTS	5W-30			X	
	G-Profi GT	10W-40			X	
	Gazprom Diesel Ultra Plus 10W-40	10W-40			X	
	Gazprom Diesel Ultra 15W-40	15W-40			X	
Gulf Oil International	Gulf Fleet Force synth.	5W-30			X	
	Gulf Superfleet ELD	10W-40			X	
	Gulf Superfleet XLD	10W-40			X	
	Gulf Superfleet Synth ELD	10W-40			X	
High Industrial Lubricants & Liquids Corporation	Fastroil Force Ultra High Performance Diesel (UHPD)	10W-40			X	
Huiles Berliet S.A.	RTO Extensia RXD ECO	5W-30			X	
Iranol Oil Co.	Iranol D40000-EIII	10W-40			X	
Kuwait Petroleum	Q8 T 860	10W-40		X		
	Q8 T 860 10W-40	10W-40			X	
	Q8 T 860 D	10W-40			X	
	Q8 T 860 S	10W-40			X	
	Q8 T 905	10W-40	X			
Lotos Oil	Turdus Powertec 3000	10W-40			X	
	Turdus Powertec Synthetic	5W-30			X	
Lukoil Lubricants Europe Oy	Teboil Super XLD-2	5W-30			X	
	Teboil Super XKD RW 10W-40	10W-40			X	
Meguin	Megol Motorenöl Super LL Dimo Premium	10W-40			X	

Multi-grade oils – Category 3, SAE grades 5W-30, 5W-40, 10W-40 and 15W-40 for diesel engines

Manufacturer	Brand name	SAE viscosity class	TBN			Remarks
			8 to 10 mgKOH/g	10 to 12 mgKOH/g	>12 mgKOH/g	
MOL-LUB Kft	MOL Synt Diesel	10W-40	X			
	MOL Dynamic Synt Diesel E4	10W-40		X		
Motorex AG	MC Power Plus SAE 10W/40	10W-40		X		
Orlen Oil Sp.o.o.	Platinum Ultor Max	5W-30		X		
OOO LLK International	Lukoil Avantgarde Professional	5W-30		X		
	Lukoil Avantgarde Professional	10W-40		X		
	Lukoil Avantgarde Professional M5	10W-40		X		
	Lukoil Avantgarde Professional M6	5W-30		X		
	Lukoil Avantgarde Professional M6	10W-40		X		
	Lukoil Avantgarde Ultra M3	15W-40		X		
Panolin	Panolin Diesel HTE	10W-40		X		
Petrogal, S.A.	Galp Galaxia Extreme	5W-30	X			
	Galp Galaxia Ultra XHP	10W-40		X		
Petromin Oils Company	Petromin Turbo Master LD	10W-40		X		
Petronas Lubricants International	Urania 5000 10W-40			X		
	Urania 5000 F	5W-30		X		
PHI OIL GmbH	Motordor Silver 10W40	10W-40		X		
Raj Petro Specialities P Ltd.	Zoomol Rforce 8200 RF1	10W-40		X		
Ramoil S.p.A.	Duglas Oil Ultra HC 10W-40 UHPDO	10W-40		X		
Ravensberger Schmierstoff Vertrieb GmbH	RAVENOL Super Performance Truck	5W-30		X		
	RAVENOL Performance Truck	10W-40		X		
Repsol Lubricantes y Especialidades S.A.	Repsol Turbo UHPD	10W-40		X		
	Repsol Diesel Turbo VHPD	5W-30		X		
	Repsol Diesel Turbo UHPD Urban	10W-40		X		
RN-Lubricants, LLC	Rosneft Revolux D4	10W-40		X		
	Rosneft Revolux D4 Plus	5W-30		X		
	Rosneft Revolux D4 Plus	10W-40		X		
SCT Vertriebs GmbH	Fanfaro TRD E4 UHPD	10W-40	X			
	Mannol TS-6 UHPD Eco	10W-40	X			
	Pemco Diesel G-6 Eco UHPD	10W-40	X			
Shell International Petroleum Company	Shell Rimula R5 M	10W-40		X		
	Shell Rimula R6 M	10W-40		X		
	Shell Rimula R6 ME	5W-30		X		
	Shell Rimula R6 MS	10W-40		X		
SK Lubricants Co.	ZIC X7000	5W-30		X		

TIM-ID: 0000019006 - 009

Multi-grade oils – Category 3, SAE grades 5W-30, 5W-40, 10W-40 and 15W-40 for diesel engines						
Manufacturer	Brand name	SAE viscosity class	TBN			Remarks
			8 to 10 mgKOH/g	10 to 12 mgKOH/g	>12 mgKOH/g	
SRS Schmierstoff Vertrieb GmbH	SRS Cargolub TFF	10W-40			X	
	SRS Cargolub TFL	5W-30			X	
	SRS Cargolub TFG	10W-40			X	
	SRS Cargolub TFG plus	10W-40			X	
	SRS Cargolub TFG ultra	10W-40			X	
Tedex SA	Tedex Diesel Truck UHPD (S) Motor Oil	10W-40			X	
Total Lubrifiants	Cubalub ExtraDiesel	10W-40			X	
	Total Rubia TIR 9200 FE	5W-30			X	
Transnational Blenders B. V.	Engine Oil Super EHPD	10W-40			X	
Unil Opal	Unil Opal LCM 800	10W-40			X	
Valvoline EMEA	All Fleet Superior	10W-40			X	
	Profleet	10W-40			X	
	Valvoline All-Fleet Extreme NTI	10W-40		X		
Wolf Oil Corporation N.V.	Wolf Vitaltech 10W40 Ultra	10W-40			X	

Table 22:

6.4 Multi-grade oils – Category 3.1 (Low SAPS oils), SAE grades 5W-30, 10W-30 and 10W-40 for diesel engines

For details and special features, see chapter “Lubricants for four-stroke cycle engines” (→ Page 6)

Multi-grade oils

Multi-grade oils – Category 3.1 (Low SAPS oils), SAE grades 5W-30, 10W-30 and 10W-40 for diesel engines						
Manufacturer	Brand name	SAE viscosity class	TBN			Comments / material number
			8 to 10 mgKOH/g	10 to 12 mgKOH/g	>12 mgKOH/g	
Addinol Lube Oil	Addinol Extra Truck MD 1049 LE	10W-40	X			
Aral AG	Aral Mega Turboral LA	10W-40	X			
	Aral Super Turboral LA	5W-30	X			
Atak Madeni Yağ Pas.San.Tic.Aş	Alpet Turbot MMS	10W-40		X		
Avia AG	Avia Multi LSP Extra	10W-40		X		
Avista Oil Deutschland GmbH	Avista pure EVO GER	10W-40		X		
	Avista pure EVO CK-4	5W-30	X			
	Avista pure EVO CK-4	10W-30	X			
	Avista pure EVO CK-4	10W-40	X			
	Avista pure EVO PRIME 5W-30	5W-30		X		
BayWa AG	Tectrol Super Truck Plus XL 1040	10W-40	X			
Belgin Madeni Yağlar	BELGIN LUBEX ROBUS MASTER LA 10W-40	10W-40		X		
BP p.l.c.	BP Vanellus Max Drain Eco	10W-40			X	
	BP Vanellus Max Eco 10W-40	10W-40			X	
BVG Vertriebsgesellschaft AG	Alpha Advanced Eco-Efficiency low SAPS	10W-40	X			
Castrol Ltd.	Castrol Vecton Long Drain 10W-30 E6/E9	10W-30	X			
	Castrol Vecton Long Drain 10W-40 E6/E9	10W-40	X			
	Castrol Vecton Fuel Saver 5W-30 E6/E9	5W-30	X			
Cepsa Comercial Petroleo, S.A.U.	Cepsa Eurotech LS 10W40 Plus	10W-40			X	
	Traction Pro LS	10W-40			X	
Champion Chemicals N.V.	Champion OEM Specific 10W40 Ultra MS	10W-40		X		
	Champion OEM Specific 10W40 UHPD	10W-40			X	
Chevron Lubricants (Caltex)	Delo XLE Multigrade	10W-40	X			

Multi-grade oils – Category 3.1 (Low SAPS oils), SAE grades 5W-30, 10W-30 and 10W-40 for diesel engines

Manufacturer	Brand name	SAE viscosity class	TBN			Comments / material number
			8 to 10 mgKOH/g	10 to 12 mgKOH/g	>12 mgKOH/g	
Chevron Lubricants (Chevron)	Delo 400 RDE	10W-30		X		
	Delo 400 RDS	10W-40		X		
	Delo 400 XLE	15W-40	X			
	Delo 400 XLE HD	5W-30			X	
	Delo 400 XLE HD	10W-40			X	
	Delo 400 XLE SYN-HD	10W-40			X	
	Delo 400 XLE Synthetic	5W-30	X			
	Delo 400 LE Synthetic	5W-30	X			
	Delo 400 XSP	5W-30	X			
	Delo 400 XSP-SD	5W-30	X			
Chevron Lubricants (Texaco)	Ursa Ultra X	10W-30		X		
CONDAT Lubrifiants	Vicam Planet 10W40	10W-40			X	
Deutsche Ölwerke Lubmin GmbH	AVENO Universal UHPD	10W-40				
De Oliebron B.V.	Tor Turbosynth LSP Plus	10W-40			X	
Ellis Enterprises B.V.	Valvoline Profleet LA	5W-30	X			
	Profleet LA	5W-30	X			
eni S.p.a.	eni i-Sigma top MS	10W-40	X			
Enoc Marketing L.L.C.	Enoc Vulkan Green	10W-40			X	
Exol Lubricants Ltd.	Taurus Euro	10W-40		X		
Exxon Mobil Corporation	Mobil Delvac 1 ESP	5W-30		X		
	Mobil Delvac 1 LE	5W-30	X			
	Mobil Delvac 1 LE	5W-30			X	
	Mobil Delvac HD	10W-40		X		
	Mobil Delvac XHP ESP	10W-40			X	
	Mobil Delvac XHP ESP M	10W-40			X	
	Mobil Delvac XHP ESP S	10W-40			X	
	Mobil Delvac XHP LE	10W-40			X	55 gallons: 800141
	Mobil Delvac XHP Ultra LE	5W-30		X		
Finke Mineralölwerk GmbH	AVIATICON Finko Super Truck LA Plus	10W-40		X		
Fuchs Petrolub SE	Titan Cargo Maxx	5W-30			X	
	Titan Cargo Maxx	10W-40			X	Enhanced corrosion protection
	Fuchs Titan Cargo EU6	5W-30	X			
	Fuchs Titan Cargo LA	5W-30	X			
	PENTOTRUCK ULTRA SAE 10W-30	10W-30	X			

TIM-ID: 0000019019 - 011

Multi-grade oils – Category 3.1 (Low SAPS oils), SAE grades 5W-30, 10W-30 and 10W-40 for diesel engines						
Manufacturer	Brand name	SAE viscosity class	TBN			Comments / material number
			8 to 10 mgKOH/g	10 to 12 mgKOH/g	>12 mgKOH/g	
Gazpromneft Lubricants Ltd.	G-Profi GT LA	10W-40			X	
Gulf Oil International	Gulf Superfleet ULE	10W-40	X			Enhanced corrosion protection
	Gulf Superfleet Synth ULE	5W-30	X			
	Gulf Superfleet XLE	10W-30	X			
	Gulf Superfleet XLE	10W-40	X			
	Gulf Superfleet Synth XLE	10W-30		X		
	Gulf Superfleet Synth XLE	10W-40	X			
	Gulf Superfleet Universal	5W-30			X	
	Gulf Superfleet Universal	10W-40			X	
Helios Lubeoil	Helios Premium KMXX 10W-40	10W-40	X			
Huiles Berliet S.A.	RTO Extensia FP	10W-40	X			
Igol	PRO 200 X	10W-40	X			
INA Maziva d.o.o.	INA Super 2009 5W-30	5W-30	X			
	INA Super 2009	10W-40			X	
Kuwait Petroleum R&T	Q8 905	10W-40	X			
	Q8 T 904	10W-40		X		
	Q8 T 904 FE	10W-30	X			
	Q8 T 905	10W-40	X			
	Q8 T 910	5W-30	X			
	Q8 Formula Truck 8500	10W-40	X			
	Q8 Formula Truck 8500 FE	10W-30	X			
	Q8 Formula Truck 8700 FE	5W-30	X			
	Q8 Formula Truck 8900 FE	5W-30	X			
LLK finland Oy	Teboil Super XLD-2	5W-30			X	
Meguin GmbH & Co. KG	megol Motorenoel Low Saps	10W-40		X		
MOL-LUB Ltd.	MOL Dynamic Mistral XT5W-30	5W-30	X			
	MOL Dynamic Mistral 10W-40	10W-40	X			
Morris Lubricants	Ring Free Ultra	10W-40		X		
	Fendt Power Grade 10W-40	10W-40		X		
	Versimax HD8	10W-40	X			
Motorex AG	Motorex Focus QTM	10W-40	X			
	Motorex / York Focus QTM	10W-40	X			
	Motorex / York Nexus FE SAE 5W-30	5W30			X	
	Motorex Nexus FE SAE 5W-30	5W30	X			

TIM-ID: 000019019 - 011

Multi-grade oils – Category 3.1 (Low SAPS oils), SAE grades 5W-30, 10W-30 and 10W-40 for diesel engines

Manufacturer	Brand name	SAE viscosity class	TBN			Comments / material number
			8 to 10 mgKOH/g	10 to 12 mgKOH/g	>12 mgKOH/g	
MPM International Oil Company B.V.	Motor Oil 10w-40 Premium Synthetic Ultra High Performance Diesel	10W-40		X		
Neste Markkinointi Oy Lubricants	Neste Turbo+ LSA 5W-30	5W-30	X			
Oel-Brack AG	Midland maxtra	10W-40		X		
OMV Petrol Ofisi A.Ş	Maximus HD-E	5W-30	X			
OOO LLK International	Lukoil Avantgarde CNG	10W-40	X			
	Lukoil Avantgarde Professional LE	5W-30			X	
	Lukoil Avantgarde Professional LE	10W-40			X	
	Lukoil Avantgarde Professional LS	5W-30	X			
	Lukoil Avantgarde Professional LS	10W-40			X	
	Lukoil Avantgarde Professional LS5	5W-30	X			
	Lukoil Avantgarde Professional LS5	10W-40	X			
	Lukoil Avantgarde Professional XLE	5W-30			X	
	Lukoil Avantgarde Professional XLE	10W-40			X	
Orlen Oil	Platinum Ultor Complete	10W-40	X			
	Platinum Ultor Optimo	10W-30	X			
	Platinum Ultor Progress	10W-40		X		
	Mogul Diesel L-SAPS	10W-40		X		
Oscar Lubricants LLC	Oscar Zircon Novus	10W-40	X			
Panolin	Panolin Diesel Synth EU-4	10W-40	X			
	Panolin Ecomot	5W-30		X		
	Panolin Ecomot	10W-30	X			
	Panolin Ecomot	10W-40	X			
Petro-Canada Lubricants Inc.	Duron SHP E6	10W-40		X		
	Duron UHP 5W30	5W-30	X			
	Duron UHP E6	5W-30			X	
	Duron UHP E6	10W-40			X	
	Duron UHP E6 10W40	10W-40	X			
Petrogal, S.A.	Galp Galaxia Ultra LS	10W-40	X			
Petrolube Lubricants	Euromax	10W-40		X		

TIM-ID: 0000019019 - 011

Multi-grade oils – Category 3.1 (Low SAPS oils), SAE grades 5W-30, 10W-30 and 10W-40 for diesel engines

Manufacturer	Brand name	SAE viscosity class	TBN			Comments / material number
			8 to 10 mgKOH/g	10 to 12 mgKOH/g	>12 mgKOH/g	
Petronas Lubricants International	Petronas Urania 5000 E	5W-30			X	
	Petronas Urania 5000 E	10W-40			X	
	Petronas Urania 5000 LS-FX	5W-30		X		
	Petronas Urania 5000 LSF 5W-30	5W-30	X			
	Petronas Urania 5000 LS 10W-40	10W-40	X			
	Petronas Urania FE LS	5W-30			X	
	Petronas Urania Ecotech	10W-40			X	
PHI OIL GmbH	Motodor LSP Gold 5W30	5W-30			X	
	Motodor LSP Silver	10W-40		X		
Prista Oil Ad	Prista UHPD	10W-40	X			
Ravensberger Schmierölvertrieb GmbH	Ravenol Euro VI Truck	10W-40	X			
	Ravenol Euro VI Truck SAE 10W-40	10W-40		X		
Repsol Lubricantes y Especialidades, S.A.	Repsol Diesel Turbo UHPD MID SAPS	10W-40	X			
	Repsol DieselTurbo VHPD Mid Saps	5W-30		X		
RN-Lubricants LLC	Rosneft Revolux D6	10W-40		X		
	Rosneft Revolux D6 Plus	5W-30			X	
	Rosneft Revolux D6 Plus	10W-40			X	
Rowe Mineralölwerk GmbH	Rowe Hightec Truckstar SAE 10W-40 HC-LA	10W-40		X		
Shell International Petroleum Company	Shell Fleet Pro CK-4	5W-30		X		
	Shell Rimula K10	10W-40			X	Enhanced corrosion protection
	Shell Rimula R6 LM	10W-40	X			Enhanced corrosion protection
	Shell Rimula R6 LME	5W-30		X		
	Shell Rimula R6 LME Plus	5W-30		X		
	Shell Rimula Ultra	5W-30			X	
	Shell Sirius S6 LM	10W-40			X	

TIM-ID: 0000019019 - 011

Multi-grade oils – Category 3.1 (Low SAPS oils), SAE grades 5W-30, 10W-30 and 10W-40 for diesel engines						
Manufacturer	Brand name	SAE viscosity class	TBN			Comments / material number
			8 to 10 mgKOH/g	10 to 12 mgKOH/g	>12 mgKOH/g	
SRS Schmierstoff Vertrieb GmbH	SRS Antikorrol MLA	10W-40		X		Enhanced corrosion protection
	SRS Cargolub TLA	10W-40	X			
	SRS Cargolub TLA plus	10W-40		X		
	SRS Cargolub TLS	5W-30			X	
	SRS Cargolub TLS plus	5W-30		X		
	SRS Cargolub TLS top	5W-30	X			
	SRS Turbo Diesel LA	10W-40	X			
	SRS Cargolub low-friction engine oil LA	10W-40		X		
	SRS Turbo-Rekord top FE	10W-40		X		
	SRS Turbo-Rekord ultra FE	10W-40	X			
Total Lubrifiants	Total Rubia TIR 8900	10W-40	X			
	Total Rubia Works 2500	10W-40	X			
	Total Rubia Works 3000	10W-40		X		
	Total Rubia Works 3000 FE	5W-30			X	
Valvoline EMEA	Valvoline ProFleet LS	5W-30			X	
	Valvoline ProFleet LS	10W-40	X			
	ProFleet LS NTI	10W-40	X			
Veedol International Limited	VEEDOL MARATRON EXTRA LSP 10W-40	10W-40		X		
Wibo Schmierstoffe GmbH	Wibokraft Ultra AF 10W40	10W-40		X		
Wolf Oil Corporation N.V.	Wolf Officialtech 10W40 Ultra MS	10W-40		X		
	Wolf Officialtech 10W40 UHPD	10W-40			X	

Table 23:

6.5 Lubricating greases for diesel engine-generator set components

Important		
Mixtures of different greases are not permitted!		
Manufacturer	Brand name	Notes
Exxon Mobil Corporation	Mobil Polyrex EM	High-temperature grease: Lubricity in the range from -30 to 250 °C (-22 to 482 °F) For: <ul style="list-style-type: none"> • Generator bearings of Marathon generators • Generator bearings of Leroy-Somer generators^{*)} • Fan wheel and belt pulley bearing on electrically driven coolant cooler, Series 4000
Shell	GADUS S3 V220C	For generator bearings of Leroy-Somer generators ^{*)}
SKF	Mehrzweckfett LGMT2	For generator bearings of HM generators
ROCOL Limited	Rocol RTD-Compound	For belt tensioner on electrically driven coolant cooler, Series 4000
ASCO Power Technologies	Lubrication Kit 75-100	For automatic transfer switch (ATS) ASCO

^{*)} NOTE: For information about the applicable lubricating greases for Leroy-Somer generators, refer to the nameplate on the generator.

For information about lubricating greases for generators made by other manufacturers, please contact the service partners.

7 Approved Coolants

7.1 Antifreeze concentrates on ethylene glycol basis

For details and special information, see chapter on “Coolants”(→ Page 13).

Manufacturer	Brand name	Inhibitors					Runtime Hours / Years	Comments / Material no.
		Organic	Silicon	Nitrite	Phosphate	Molybdate		
Rolls-Royce Solutions GmbH	Coolant AH100 Antifreeze Concentrate	X	X				9000 / 5	X00057231 (20 l) X00057230 (210 l) also available through mtu Asia
Alliance Automotive Service GmbH	NAPA Premium Kühlerschutz N48	X	X				9000 / 5	
Avia AG	Antifreeze APN	X	X				9000 / 5	
	Antifreeze APN - S	X					9000 / 3	
BASF SE	Glysantin® G30 pink	X					9000 / 3	X00058072 (canister) X00058071 (barrel)
	Glysantin® G40 pink	X	X				9000 / 3	X00066724 (20 l) X00066725 (210 l)
	Glysantin® G48 blue green	X	X				9000 / 5	X00058054 (25 l) X00058053 (210 l)
BayWa AG	Tectrol Coolprotect	X	X				9000 / 5	
BP Lubricants	Aral Antifreeze Extra	X	X				9000 / 5	
Castrol	Castrol Radicool NF	X	X				9000 / 5	
Classic Schmierstoff GmbH + Co KG	Classic Kolda UE G48	X	X				9000 / 5	
CCI Corporation	L 415	X				X	9000 / 3	
Comma Oil & Chemicals Ltd.	Comma Xstream® G30® Antifreeze Coolant Concentrate	X					9000 / 3	
	Comma Xstream® G48® Antifreeze Coolant Concentrate	X	X				9000 / 5	
COPARTS Autoteile GmbH	CAR1 Premium Longlife Kühlerschutz C48	X	X				9000 / 5	
Daimler Trucks North America	Alliance OAT Extended Life Coolant	X				X	9000 / 3	
Detroit Diesel Corp.	Power Cool Plus Coolant	X				X	9000 / 3	
Drew Marine	Drewgard ZX	X					9000 / 3	

TIM-ID: 0000084443 - 005

Manufacturer	Brand name	Inhibitors					Runtime Hours / Years	Comments / Material no.
		Organic	Silicon	Nitrite	Phosphate	Molybdate		
ExxonMobil	Mobil Delvac Extended Life Coolant	X				X	9000 / 3	
	Mobil Antifreeze Advanced	X					9000 / 3	
	Mobil Antifreeze Extra	X	X				9000 / 5	
	Esso Antifreeze Advanced	X					9000 / 3	
	Esso Antifreeze Extra	X	X				9000 / 5	
Finke Mineralölwerk GmbH	AVIATICON Finkofreeze F30	X					9000 / 3	
	AVIATICON Finkofreeze F40	X	X				9000 / 3	
	AVIATICON Finkofreeze F48	X	X				9000 / 5	
Fuchs Petrolub SE	Maintain Fricofin	X	X				9000 / 5	
	Maintain Fricofin G12 Plus	X					9000 / 3	X00058074 (canister) X00058073 (barrel)
INA Maziva Ltd.	INA Antifriz AI Super	X	X				9000 / 5	
Kuttenkeuler GmbH	Kuttenkeuler Antifreeze ANF KK48	X	X				9000 / 5	
	Glycostar®ST48	X	X				9000 / 5	
LLK-International (Lukoil Lubricants Co.)	Lukoil Antifreeze HD G 12 K	X					9000 / 3	
Lukoil Lubricants Europe GmbH	Lukoil Coolant Plus	X	X				9000 / 5	
	Lukoil Coolant SF	X					9000 / 3	
	Lukoil Coolant SOT	X	X				9000 / 3	
Mitran Mineralöl GmbH	Alpine C30	X					9000 / 3	
	Alpine C48	X	X				9000 / 5	
MIL Bangladesh Ltd.	Omera Premium Coolant	X					9000 / 3	
Mofin Deutschland GmbH & Co KG	MOFIN Kühlerschutz M40 Extra	X	X				9000 / 3	
	MOFIN Kühlerschutz M48 Premium Protect	X	X				9000 / 5	
Motorex AG	Motorex Coolant G48	X	X				9000 / 5	
	Motorex Coolant M 4,0 Concentrate	X	X				9000 / 3	
Nalco Water An Eco-lab Company	Nalcool NF 48C	X	X				9000 / 5	
Navistar Inc.	Fleetrite-Free Extended Life Coolant	X				X	9000 / 3	

Manufacturer	Brand name	Inhibitors					Runtime Hours / Years	Comments / Material no.
		Organic	Silicon	Nitrite	Phosphate	Molybdate		
Old World Industries Inc.	Blue Mountain Heavy Duty Extended Life Coolant	X				X	9000 / 3	
	Final Charge Global Extended Life Coolant Antifreeze	X				X	9000 / 3	
Panolin AG	Panolin Anti-Frost MT-325	X	X				9000 / 5	
Penske Power Systems	Power Cool - HB500 Coolant Concentrate	X	X				9000 / 3	
Puma Energy International S.A.	Puma HD Hybrid Coolant	X	X				9000 / 3	
Raloy Lubricantes	Antifreeze Long Life NF-300 Concentrate	X	X				9000 / 5	
Recochem Inc.	HD Expert™ Endurance	X				X	9000 / 3	
	R542	X	X				9000 / 3	
SMB - Sotagal / Mont Blanc	Antigel Power Cooling Concentrate	X	X				9000 / 5	
Total Lubrifiants	Glacelf MDX	X	X				9000 / 5	
Valvoline	Zerex G-30	X					9000 / 3	
	Zerex G-40	X	X				9000 / 3	Material number (USA): 800180 (Drum)
	Zerex G-48	X	X				9000 / 5	
	OEM Advanced 30	X					9000 / 3	
	OEM Advanced 40	X	X				9000 / 3	
	OEM Advanced 48	X	X				9000 / 5	
Volvo Trucks	Road Choice Nitrite-Free OAT Extended Life Coolant	X				X	9000 / 3	
York SAS	York 716	X	X				9000 / 5	

Table 24: Antifreeze concentrates on ethylene glycol basis

7.2 Antifreeze ready mixtures on ethylene glycol basis

For details and special information, see chapter on “Coolants”(→ Page 13).

Manufacturer	Brand name	Inhibitors					Runtime Hours / Years	Comments / Material no.
		Organic	Silicon	Nitrite	Phosphate	Molybdate		
Rolls-Royce Solutions GmbH	Coolant AH 50/50 Antifreeze Premix	X	X				9000 / 5	X00070528 (20 l) X00070530 (210 l) X00070527 (1000 l) (sales region: England)
	Coolant AH 40/60 Antifreeze Premix	X	X				9000 / 5	X00070533 (20 l) X00070531 (210 l) X00070532 (1000 l) (sales region: England, Spain)
Rolls-Royce Solutions America Inc.	Power Cool® Universal 50/50 mix	X	X				9000 / 5	800069 (1 gallon) 800071 (5 gallons) 800084 (55 gallons)
Bantleon	Avilub Antifreeze Mix (50%)	X	X				9000 / 5	X00049213 (210 l)
BayWa AG	Tectrol Coolprotect Mix-3000	X					9000 / 3	
Castrol	Castrol Radicool NF Premix (45%)	X	X				9000 / 5	
CCI Corporation	L 415 (50%)	X				X	9000 / 3	
Cepsa Comercial Petróleo S.A.U.	XTAR Super Coolant Hybrid NF 50%	X	X				9000 / 5	
Daimler Trucks North America	Alliance 50/50 Prediluted OAT Extended Life Coolant	X				X	9000 / 3	
Detroit Diesel Corp.	Power Cool Plus Prediluted Coolant (50/50)	X				X	9000 / 3	
Exxon Mobil	Mobil Delvac Extended Life Prediluted Coolant (50/50)	X				X	9000 / 3	
Finke Mineralölwerk GmbH	AVIATICON Finkofreeze F48 RM 50/50	X	X				9000 / 5	
	AVIATICON Finkofreeze F30 RM 40:60 +	X					9000 / 3	
LLK-International (Lukoil Lubricants Co)	Lukoil Antifreeze HD G 12 (50%)	X					9000 / 3	
Motorex AG	Motorex Coolant G48 ready to use (50/50)	X	X				9000 / 5	
	Motorex Coolant M 4,0 Ready to use	X	X				9000 / 3	Antifreeze protection up to -38 °C
Navistar Inc.	Fleetrite 50/50 Prediluted Nitrite-Free Life Coolant	X				X	9000 / 3	

TIM-ID: 0000084448 - 005

Manufacturer	Brand name	Inhibitors					Runtime Hours / Years	Comments / Material no.
		Organic	Silicon	Nitrite	Phosphate	Molybdate		
Old World Industries Inc.	Blue Mountain Heavy Duty Extended Life Prediluted Coolant (50/50)	X				X	9000 / 3	
	Final Charge Global Extended Life Prediluted Coolant/ Antifreeze (50/50)	X				X	9000 / 3	
Penske Power Systems	Power Cool - HB500 Premix 50/50	X	X				9000 / 3	
Puma Energy International S.A.	Puma HD Hybrid Coolant 5050	X	X				9000 / 3	(50% by volume)
Raloy Lubricantes	Antifreeze Long Life NF-300 Ready-to-Use (50/50)	X	X				9000 / 5	
Recochem Inc.	HD Expert™ Endurance 50-50 Prediluted	X				X	9000 / 3	
SMB - Sotragal / Mont Blanc	L.R.-30 Power Cooling (44%)	X	X				9000 / 5	
	L.R.-38 Power Cooling (52%)	X	X				9000 / 5	
Total Lubrificants	Coolelf MDX -26 °C	X	X				9000 / 5	
	Coolelf MDX -37 °C	X	X				9000 / 5	
Tosol-Sintez	Glystantin Alu Protect G30 Ready Mix	X					9000 / 3	
	Glystantin Alu Protect Plus G48 Ready Mix	X	X				9000 / 5	
Valentin Energie GmbH	Valentin Coolant Plus -25 °C Ready	X					9000 / 3	
Valvoline	Zerex G-48 premix 50%	X	X				9000 / 5	
	OEM Advanced 48 premix 50%	X	X				9000 / 5	
Volvo Trucks	Road Choice 50/50 Prediluted Nitrite-Free OAT Extended Life Coolant	X				X	9000 / 3	
YPF S.A. Argentina	Kriox MTL50	X				X	9000 / 3	

Table 25: Antifreeze ready mixtures on ethylene glycol basis

8 Flushing and Cleaning Specifications for Engine Coolant Circuits

8.1 General information

In the course of time, sludge deposits from aging coolant additives can accumulate in the coolant circuits. Reduced cooling capacity, clogged vent lines and drain points and dirty coolant level sight glasses can result.

Below-standard water quality or incorrect coolant preparation can also heavily contaminate the system.

If such conditions occur, the coolant circuit is to be flushed out with freshwater, repeatedly if necessary.

If these flushing sequences are insufficient or if the system is too heavily contaminated, the coolant circuit and all affected assemblies must be cleaned.

Only clean, freshwater (no river or sea water) must be used for flushing.

Only products approved by Rolls-Royce Solutions or corresponding products (→ Page 72) at the specified concentrations may be used for cleaning. The specified cleaning procedure is to be complied with.

Immediately after flushing or cleaning, fill the coolant circuits with treated engine coolant as stipulated in these Fluids and Lubricants Specifications (→ Page 13). Otherwise there is a danger of corrosion!

Important

Fluids and lubricants (e.g. treated engine coolant), used flushing water, cleaning agents and cleaning solutions can be hazardous materials. Certain regulations must be obeyed when handling, storing and disposing of these substances.

These regulations are contained in the manufacturer's instructions, statutory requirements and technical guidelines valid in the individual countries. Considerable differences can apply from country to country so that no generally valid statement on the applicable regulations for fluids and lubricants etc. can be made in this publication.

Users of the products named in these specifications are therefore obliged to inform themselves of the locally valid regulations. Rolls-Royce Solutions accepts no responsibility whatsoever for improper or illegal use of the fluids and lubricants / cleaning agents which it has approved.

Important

Scrap oil heat exchangers from engines with bearing or piston seizures or friction damage!

Test equipment, auxiliary materials and fluids and lubricants

mtu test kit or electrical pH-value measuring instrument

- Freshwater
- Prepared engine coolant
- Superheated steam
- Compressed air

8.2 Approved cleaning agents

Manufacturer	Product name	Working concentration		Order no.
For coolant systems:				
Klute	Hakutex 111 ^{1, 5)}	2% by volume	Liquid	X00065751
	Decorrdal 20-1 ⁸⁾	10% by volume	Liquid	⁷⁾
	Hakupur 50-706-3 ⁴⁾	2% by volume	Liquid	X00055629
For cooling circuit assemblies:				
Henkel	Bonderite C-AK FD ²⁾	1 to 10% by weight	Powder	⁷⁾
	Bonderite C-MC 11120 ³⁾	2 to 10% by weight	Powder	⁷⁾
Klute	Hakutex 60 mtu ⁹⁾	100% by volume	Liquid	X00070585 (25 kg)
For coolant systems contaminated with bacteria, fungi or yeast (so-called system cleaners):				
Vink Chemicals	Grotan WS Plus ⁵⁾	0.15% by volume	Liquid	X00065326 (10 kg)
	Grotanol SR2 ⁶⁾	0.5% by volume	Liquid	X00069827 (10 kg)

Table 26:

¹⁾ For light lime deposits, light corrosion

²⁾ For lime deposits containing oil and grease

³⁾ Preferred for heavy lime deposits

⁴⁾ For oily and greasy residues. Not suitable for galvanized surfaces

⁵⁾ Bacteria contamination up to 10^4

⁶⁾ Bacteria contamination up to $> 10^4$, contamination with fungi and yeast

⁷⁾ Not stocked by Rolls-Royce Solutions

⁸⁾ With serious corrosion; not permitted for aluminum materials

⁹⁾ Solvent cold cleaner for oily and greasy residues

Important

The technical data sheets and safety data sheets of the product must be observed!

The cleaning agents are available world-wide through the branches of the manufacturers or their trading partners.

8.3 Engine coolant circuits - Flushing

1. Drain engine coolant.
2. Measure the pH value of the freshwater using the mtu test kit or an electrical pH value measuring device.
3. Fill freshwater into the coolant circuit.

Important

Never pour cold water into a hot engine!

4. Preheat the engine, start it up and run until warm.
5. Run engine at increased speed for approx. 30 minutes.
6. Take flushing liquid sample at engine-coolant-sample extraction cock.
7. Shut down engine.
8. Drain flushing liquid.
9. Measure pH value of flushing liquid sample using the mtu test kit or electrical pH value measuring device and compare with the pH value of the freshwater.
 - a) pH value difference < 1 : Fill system with treated coolant and start engine.
 - b) pH value difference > 1 : Fill with fresh flushing liquid and repeat flushing cycle.
 - c) If the pH value difference is still > 1 even after flushing 4 to 5 times the coolant circuit must be cleaned, see (→ Page 74). The assemblies may also need cleaning, see (→ Page 75).

Important

Refer to the engine operating instructions for additional information.

8.4 Engine coolant circuits – Cleaning

1. Mix cleaner to the specified concentration with freshwater. Use warm freshwater (45 °C) if the engine is warm.
2. Cleaning agents for coolant circuits are prepared in warm freshwater as a concentrated solution, see (→ Page 72).
3. In the case of powdered products, stir until the cleaning agent is completely dissolved and without sediment.
4. Pour solution together with freshwater into coolant circuit.
5. Start engine and run until warm.
6. Select temperature and duration of residence time according to the specifications of the technical data sheets of the manufacturer.
7. Shut down engine.
8. Drain off cleaning agents and flush the engine coolant circuit with fresh water.
9. Take flushing liquid sample at engine-coolant-sample extraction cock.
10. Measure pH value of flushing liquid sample using the mtu test kit or electrical pH value measuring device and compare with the pH value of the freshwater.
 - a) pH value difference < 1: Fill system with treated coolant and start engine.
 - b) pH value difference > 1: Clean assemblies, see (→ Page 75).

Important

Refer to the engine operating instructions for additional information.

8.5 Cleaning engine coolant circuit assemblies

1. Remove, disassemble and clean assemblies in the engine coolant circuit that are exposed to heavy sludge deposits e.g. expansion tanks, preheating units, heat exchangers (coolant cooler, oil heat-exchanger, charge-air cooler, charge-air preheater, fuel preheater etc.) and lower sections of pipework.
2. Before cleaning, examine degree of contamination on water sides.
3. In case of lime deposits that contain oil and grease, degrease the water side first.
4. Deposits in charge-air coolers caused by oil mist can be removed using Kluthe Hakutex 60.
5. Remove hard lime deposits with a decalcifying product. In the event of stubborn lime deposits, if necessary a 10% inhibited hydrochloric acid solution may have to be used.
6. Dissolve deposits on and in heat-exchanger elements in a heated cleaning bath. Observe the manufacturer's specifications and use only approved detergents in the permissible concentration, see (→ Page 72)

Important

Deposits on the oil side can also be dissolved in a kerosene bath.
The dwell time in the cleaning bath depends on the type and degree of contamination, as well as the temperature and activity of the bath.

7. Clean individual components such as housings, covers, pipes, sight glasses, heat-exchanger elements with superheated steam, a nylon brush (soft) and a powerful water jet.

Important

In order to avoid damage:
Do not use hard or sharp-edged tools (steel brushes, scrapers, etc.) (oxide protective layer).
The pressure of the water jet must not be ≤ 60 bar (to avoid damage, e.g. of the cooler fins).

8. After cleaning, blow through the heat exchanger elements with low-pressure steam in the direction opposite to operational flow, rinse with clear water (until pH-value difference is < 1) and blow dry with compressed or hot air.
9. Check that all components are in perfect condition, repair or replace as necessary.
10. Flush oil and engine coolant sides of heat-exchanger elements with corrosion-inhibiting oil. This step may be omitted if the heat exchanger is installed and taken into service immediately after cleaning.
11. After installing all assemblies, flush engine coolant circuit once, see (→ Page 73).
12. Check coolant system for leaks during initial operation of engine.

Important

For further information, see the Maintenance Manual for the engine in question.

8.6 Coolant circuits contaminated with bacteria, fungi or yeast

System cleaning

The system cleaner must flow a sufficiently long time through the complete cooling system to ensure effective cleaning and disinfection.

Therefore, the predefined amount of the approved system cleaner must be added to the contaminated coolant in the system, see (→ Page 72). Use a circulating pump to provide continuous mixture flow through the coolant system for at least 24 hours or max. 48 hours.

Flushing

When the coolant and system cleaner have been drained, the cooling circuit must be flushed with fresh water. Flushing must be carried out until no more contaminants are visible and the flushing liquid has the same pH-value as the fresh water used (max. pH-value difference < 1).

Refill

Before refilling the circuit, make sure the system is free of contaminants.

Refill must be performed directly after flushing to avoid the risk of corrosion!

9 Cleaning

9.1 General information

If, in the course of time, contaminants such as oil deposits and leaves have accumulated on the engine, it might be necessary to clean it. This should be done with due care and only on the surface.

Wash-cleaning the engine can - at the worst - have the opposite effect if it is carried out incorrectly.

Before getting started and using cleaning agents, electrical components (battery-charging generator, plug connections, ignition cables etc.) and the air intake should be protected with covers to avoid water ingress into the plug connections or combustion chambers, which could cause damage.

Only clean freshwater (no river or sea water) must be used for spray-washing.

All plug connections should be checked and, if necessary, blown out with compressed air after cleaning to avoid misfiring and other electrical problems.

Only products approved by Rolls-Royce Solutions GmbH at the specified concentrations may be used for cleaning. The specified cleaning procedure is to be complied with.

Important

Cleaning must be carried out with pressure washers at an operating pressure of ≤ 60 bar to avoid damage to the cooler and the engine. High-pressure cleaners with an operating pressure > 60 bar are not permitted.

After the clean-washing procedure, the equipment must be thoroughly rinsed with freshwater. The specifications in the chapter "Fresh water requirements for cleaning solutions and flushing water" are applicable. The technical data sheets and safety data sheets of the product must be observed!

Important

Fluids and lubricants (e.g. treated engine coolant), used flushing water, cleaning agents and cleaning solutions can be hazardous materials. Certain regulations must be obeyed when handling, storing and disposing of these substances.

These regulations are contained in the manufacturer's instructions, statutory requirements and technical guidelines valid in the individual countries. Considerable differences can apply from country to country so that no generally valid statement on the applicable regulations for fluids and lubricants etc. can be made in this publication.

Users of the products named in these specifications are therefore obliged to inform themselves of the locally valid regulations. Rolls-Royce Solutions GmbH accepts no responsibility whatsoever for improper or illegal use of the fluids and lubricants / cleaning agents which it has approved.

Test equipment, auxiliary materials and fluids and lubricants

mtu test kit or electrical pH-value measuring instrument

- Freshwater
- Superheated steam
- Compressed air

9.2 Approved cleaning agents

Manufacturer	Product name	Working concentration		Order no.
For remote cooler on air side:				
Kluthe GmbH	Hakupur 50 K ¹⁾	0.5% by volume - 5% by volume	Liquid	X00070940 ²⁾
For cleaning painted, contaminated surfaces externally:				
Kluthe GmbH	Hakupur 449 ¹⁾	1% by volume	Liquid	X00071179 ²⁾

Table 27:

¹⁾ Cleaning agent for cleaning with high-pressure cleaning device (parameter: Pressure: ≤ 60 bar, gentle spray jet, distance from nozzle to object at least 25 cm, cleaning agent temperature: 80 °C)

²⁾ Not stocked by Rolls-Royce Solutions

Important

The technical data sheets and safety data sheets of the product must be observed!

The cleaning agents are available world-wide through the branches of the manufacturers or their trading partners.

10 Revision Overview

10.1 Revision overview from version A001068/03 to version A001068/04

Seq. No.	Chapter	Subject	Page	Action
1		Cover sheet	(→ Page 16)	Content updated (New Corporate Design)
2	1.1	General information	(→ Page 4)	Content updated (New Corporate Design)
3	2.3	Approved engine oils	(→ Page 23)	Content updated (New Corporate Design)
4	2.5	Complete chapter	(→ Page 50)	Content updated (New Corporate Design)
5	3.8	Complete chapter	(→ Page 54)	Content updated (New Corporate Design)
6	4.5	Series-dependent approval of diesel fuel grades for mtu engines	(→ Page 31)	Content updated (New Corporate Design)
7	4.8	Complete chapter	(→ Page 36)	Content updated (New Corporate Design)
8	6.5	Complete chapter	(→ Page 41)	Content updated (New Corporate Design)
9	Was 4.2	Diesel fuels for engines with exhaust gas aftertreatment (EGAT)		Chapter deleted

11 Index

11.1 Index

A

Antifreeze

- Concentrates 66
- Ready mixtures 69

Approved fluids and lubricants

- Antifreeze 66, 69
- Coolants 20
- Engine oils 9
- Fuel 31

C

Cleaning

- General information 77

Cleaning agent

- System cleaner 76

Cleaning agents 72, 78

Cleaning specifications

- Assemblies 75
- Engine coolant circuit 74
- System cleaner 76

Color additive

- Coolant circuit 19

Coolant 13, 20

- Application concentrations 13
- Concentrates 18
- Definition 13
- Freshwater requirements 16
- Operational monitoring 17
- Test package for North America 21
- Treatment 16

Coolant circuit

- Assembly cleaning 75
- Cleaning 74
- Cleaning agents 72, 78
- Flushing 73
- Leakage 19
- Materials 15

Cooling system

- Damage prevention 13

D

Diesel fuel

- Heating oil EL 28
- Test package for North America 38

Diesel fuel, see fuel 23

Distillate fuel 23

E

Engine coolant circuit

- Assembly cleaning 75
- Cleaning 74
- Cleaning agents 72
- Flushing 73

Engine oil

- Low SAPS
 - Category 2.1 50
 - Category 3.1 59
- Multigrade oil
 - Category 2 41
 - Category 2.1 (Low SAPS oil) 50
- Multi-grade oil
 - Category 3 54
 - Category 3.1 (Low SAPS oil) 59
- Test package for North America 12

Engine oils 9

- Change intervals 6
- Requirements 6
- Used-oil analysis 10
- Viscosity grades 8

Engine wash-cleaning procedure

- Cleaning agents 78

F

Flow improvers 23

Flushing and cleaning specifications for engine coolant circuits

- General information 71

Flushing specifications

- Assemblies 75
- Coolant circuits contaminated with bacteria, fungi or yeast 76
- Engine coolant circuits 73

Fuel 31

- Limit values 23
- Out-of-service period >1 month 37

Fuel system

- Materials 36

Fuels

- Biodiesel 27
- Supplementary fuel additives 29

G

General information and storage

- NOx reducing agent 40

H

Heating oil EL 28

L

Leakage

- Coolant circuit 19

Lubricating grease

- ATS 65
- Coolant cooler 65
- Generator 65

M

Materials

- Coolant circuit 15
- Fuel system 36

mtu Advanced Fluid Management System

- Coolant 21
- Diesel fuel 38
- Engine oil 12

N

NOx reducing agent AUS 32 for SCR aftertreatment systems 40

O

Oil change intervals 6

Operational monitoring 17

P

Preservation 4

R

Requirements

- Coolant circuit 15
- Fuel system 36

Revision overview 79

S

SCR aftertreatment systems 40

Storage capability of coolant concentrates 18

T

Test package for North America

- Coolant 21
- Diesel fuel 38
- Engine oil 12

U

Up-to-dateness of this publication 4

User instructions 4

V

Viscosity grades 8