

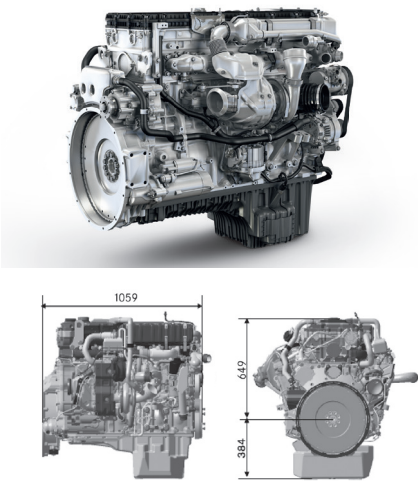

Oil & Gas

DIESEL ENGINE 6R 1100/OM 470

for oil and gas applications
with EPA tier 4 and EU stage IV certification



Engine	Dimensions (LxWxH) mm (in)	Mass, dry kg (lbs)
6R 1100 C	1325 x 955 x 1230 (52.7 x 37.6 x 48.4)	990 (2183) ¹⁾

All dimensions are approximate, for complete information refer to the installation drawing.
1) DIN 70020

Engine		
Bore/stroke	mm (in)	125/145 (4.9/5.7)
Cylinder configuration		6 inline
Displacement, total	l (cu in)	10.7 (652)
Fuel specification		DIN EN 590, ASTM D975 (DF1, DF2)

Optional equipment and finishing shown. Standard may vary.

Engine type	Rated power			Peak torque			Fuel consumption at rated power	Fuel consumption at peak torque
	kW	bhp	rpm	Nm	lb-ft	rpm	g/kWh	g/kWh
6R 1100 C 30	280	375	1700	1900	1401	1300	200	192
6R 1100 C 40	300	402	1700	2000	1475	1300	200	192
6R 1100 C 50	320	429	1700	2100	1549	1300	200	192

Ratings acc. to ECE R 120

Emissions: EPA 40 CFR 89 / Tier 4 final
EU Nonroad St IV (97/68/EC)
UN ECE R96 Emission Flex Package (EFP)

Standard Equipment	Optional Equipment
24 Volt starter	Exhaust brake system
28 Volt alternator, 100 A	Aux REPTO
Common rail injection system	Air compressor
Electronic engine management	AC compressor
Electronic interface module	Flex engine mounts
Turbo charging air to air cooling	Elevated fan drive
High pressure EGR system	Cooling fan
One-box aftertreatment system with SCR incl. muffler	
Close crankcase ventilation	
SAE 1 flywheel housing	

Reference conditions:

- > Intake temperature: 25°C (77°F)
- > Charge air temperature: 40°C
- > Altitude: 200 m (656 ft)
- > Air intake restriction: 25 mbar

Subject to change without notice. Customization possible. Engines illustrated in this document may feature options not fitted as standard to standard engine.