



Diesel Generator Set

mtu 6R0113 DS180

180 kWe/60 Hz/Standby/208 - 600V

Reference **mtu 6R0113 DS180 (180 kWe)** for Prime Power for Stationary Emergency Rating Technical Data



System ratings

Voltage (L-L)	240V †	240V †	208V †	240V †	480V †	600V
Phase	1	1	3	3	3	3
PF	1	1	0.8	0.8	0.8	0.8
Hz	60	60	60	60	60	60
kW	180	180	180	180	180	180
kVA	180	180	225	225	225	225
Amps	750	750	625	541	271	217
skVA@30% voltage dip	267	370	433	433	451	510
Generator model	432CSL6210	432PSL6228	431CSL6206	431CSL6206	431CSL6204	431PSL6243
Temp rise	130 °C/40 °C	130 °C/40 °C	130 °C/40 °C	130 °C/40 °C	130 °C/40 °C	130 °C/40 °C
Connection	12 LEAD DOUBLE DELTA	4 LEAD	12 LEAD WYE	12 LEAD DELTA	12 LEAD WYE	4 LEAD WYE

† UL 2200 offered

Certifications and standards

- Emissions
 - EPA Tier 3 certified
 - South Coast Air Quality Management District (SCAQMD)
- Generator set is designed and manufactured in facilities certified to standards ISO 9001:2008 and ISO 14001:2004
- UL 2200 - optional (refer to *System ratings* for availability)
- CSA - optional
 - CSA C22.2 No. 100
 - CSA C22.2 No. 14
- Performance Assurance Certification (PAC)
 - Generator set tested to ISO 8528-5 for transient response
 - Verified product design, quality and performance integrity
 - All engine systems are prototype and factory tested
- Power rating
 - Accepts rated load in one step per NFPA 110

Standard features*

- Single source supplier
- Global product support
- Two (2) Year/3,000 Hour Basic Limited Warranty
- 6068HFG285 diesel engine
 - 6.8 liter displacement
 - Electronic unit pump injection
 - 4-cycle
- HVO and GtL fuels meeting fuel specification EN15940
- Engine-generator resilient mounted
- Complete range of accessories
- Cooling system
 - Integral set-mounted
 - Engine-driven fan
- Generator
 - Brushless, rotating field generator
 - 2/3 pitch windings
 - 300% short circuit capability with optional Permanent Magnet Generator (PMG)
- Digital control panel(s)
 - UL recognized, CSA certified, NFPA 110
 - Complete system metering
 - LCD display

Standard equipment*

Engine

- Air cleaners
- Oil pump
- Oil drain extension and shut-off valve
- Full flow oil filter
- Fuel filter with water separator
- Jacket water pump
- Thermostat
- Blower fan and fan drive
- Radiator - unit mounted
- Electric starting motor - 12V
- Governor - electronic isochronous
- Base - formed steel
- SAE flywheel and bell housing
- Charging alternator - 12V
- Battery box and cables
- Flexible fuel connectors
- Flexible exhaust connection
- EPA certified engine

Generator

- NEMA MG1, IEEE, and ANSI standards compliance for temperature rise and motor starting
- Self-ventilated and drip-proof
- Superior voltage waveform
- Solid state, volts-per-hertz regulator
- $\pm 1\%$ voltage regulation no load to full load
- Brushless alternator with brushless pilot exciter
- 4 pole, rotating field
- 130 °C maximum standby temperature rise
- 1-bearing, sealed
- Flexible coupling
- Full amortisseur windings
- 125% rotor balancing
- 3-phase voltage sensing
- 100% of rated load - one step
- 5% maximum total harmonic distortion

Digital control panel(s)

- Digital metering
- Engine parameters
- Generator protection functions
- Engine protection
- SAE J1939 Engine ECU Communications
- Windows®-based software
- Multilingual capability
- Communications to remote annunciator
- Programmable input and output contacts
- UL recognized, CSA certified, CE approved
- Event recording
- IP 54 front panel rating with integrated gasket
- NFPA 110 compatible

Application data

Engine

Manufacturer	John Deere
Model	6068HFG85
Type	4-cycle
Arrangement	6-inline
Displacement: L (in ³)	6.8 (415)
Bore: cm (in)	10.6 (4.2)
Stroke: cm (in)	12.7 (5)
Compression ratio	17:1
Rated rpm	1,800
Engine governor	JDEC
Maximum power: kWm (bhp)	235 (315)
Steady state frequency band	± 0.25%
Air cleaner	dry

Liquid capacity

Total oil system: L (gal)	32.2 (8.5)
Engine jacket water capacity: L (gal)	11.9 (3.3)
System coolant capacity: L (gal)	29.3 (7.75)

Electrical

Electric volts DC	12
Cold cranking amps under -17.8 °C (0 °F)	925
Batteries: group size	4D
Batteries: quantity	1

Fuel system

Fuel supply connection size	-6 JIC 37° female
Fuel return connection size	-6 JIC 37° female
Maximum fuel lift: m (ft)	2 (6.7)
Recommended fuel	diesel #2/HVO
Total fuel flow: L/hr (gal/hr)	93 (24.5)

Fuel consumption

At 100% of power rating: L/hr (gal/hr)	51.9 (13.5)
At 75% of power rating: L/hr (gal/hr)	40.5 (10.7)
At 50% of power rating: L/hr (gal/hr)	27.6 (7.3)

Cooling - radiator system

Ambient capacity of radiator: °C (°F)	50 (122)
Maximum restriction of cooling air: intake and discharge side of radiator: kPa (in. H ₂ O)	0.12 (0.5)
Water pump capacity: L/min (gpm)	265 (70)
Heat rejection to coolant: kW (BTUM)	83.7 (4,766)
Heat rejection to air to air: kW (BTUM)	40 (2,298)
Heat radiated to ambient: kW (BTUM)	24.2 (1,378)
Fan power: kW (hp)	8.6 (11.5)

Air requirements

Aspirating: *m ³ /min (SCFM)	14.7 (520)
Air flow required for radiator cooled unit: *m ³ /min (SCFM)	412 (14,537)
Remote cooled applications; air flow required for dissipation of radiated generator set heat for a maximum of 25 °F rise: *m ³ /min (SCFM)	89 (3,108)

* Air density = 1.184 kg/m³ (0.0739 lbm/ft³)

Exhaust system

Gas temperature (stack): °C (°F)	528 (982)
Gas volume at stack temperature: m ³ /min (CFM)	38.8 (1,371)
Maximum allowable back pressure at outlet of engine, before piping: kPa (in. H ₂ O)	10 (40)

Weights and dimensions

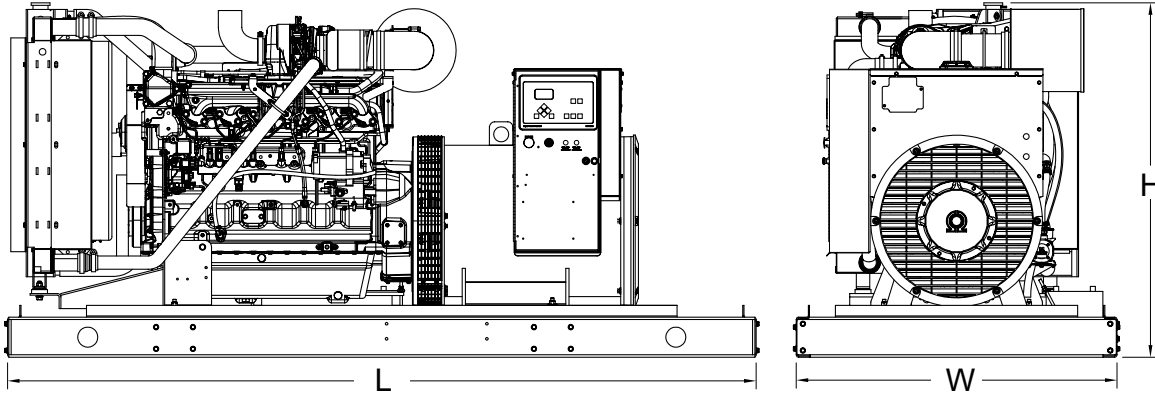

Drawing above for illustration purposes only, based on standard open power 480 volt generator set. Lengths may vary with other voltages. Do not use for installation design. See website for unit specific template drawings.

System	Dimensions (L x W x H)	Weight
Open Power Unit (OPU)	2,845 x 1,219 x 1,346 mm (112 x 48 x 53 in)	1,573-2,262 kg (3,496-4,986 lb)

Weights and dimensions are based on open power units and are estimates only. Consult the factory for accurate weights and dimensions for your specific generator set.

Sound data

Unit type	Standby full load
Level 0 (OPU): dB(A)	87.2

Sound data is provided at 7 m (23 ft). Generator set tested in accordance with ISO 8528-10 and with infinite exhaust.

Emissions data

NO _x + NMHC	CO	PM
4.63	0.49	0.09

All units are in g/hp-hr and shown at 100% load (not comparable to EPA weighted cycle values). Emission levels of the engine may vary with ambient temperature, barometric pressure, humidity, fuel type and quality, installation parameters, measuring instrumentation, etc. The data was obtained in compliance with US EPA regulations. The weighted cycle value (not shown) from each engine is guaranteed to be within the US EPA standards. 5-mode emission data per 40 CFR 89 or 40 CFR 1039 (as applicable) is available upon request.

Rating definitions and conditions

- Standby ratings apply to installations served by a reliable utility source. The standby rating is applicable to varying loads for the duration of a power outage. No overload capability for this rating. Ratings are in accordance with ISO 3046-1, BS 5514, and AS 2789. Average load factor: ≤ 85%.
- Nominal ratings at standard conditions: 25 °C and 300 meters (77 °F and 1,000 feet).
- Deration factor:
 - Consult your local **mtu** Distributor for altitude derations.
 - Consult your local **mtu** Distributor for temperature derations.