

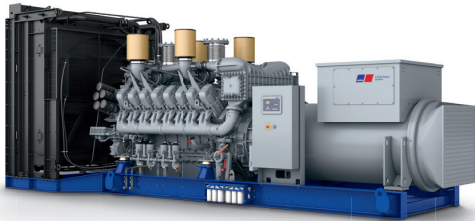

Diesel Generator Set

mtu 16V4000 DS2250

380V – 11 kV/50 Hz/grid stability power/
NOx emission optimized/16V4000G14F/water charge air cooling



Optional equipment and finishing shown. Standard may vary.

Product highlights

Benefits

- Low fuel consumption
- Optimized system integration ability
- High reliability
- High availability of power
- Long maintenance intervals

Support

- Global product support offered

Standards

- Engine-generator set is designed and manufactured in facilities certified to standards ISO 2008:9001 and ISO 2004:14001
- Generator set complies to ISO 8528
- Generator meets NEMA MG1, BS 5000, ISO, DIN EN and IEC standards
- NFPA 110

Power rating

- System ratings: 2050 kVA - 2160 kVA
- Accepts rated load in one step per NFPA 110*
- Generator set complies to G3 according to ISO 8528-5
- Generator set exceeds load steps according to ISO 8528-5*

Performance assurance certification (PAC)

- Engine-generator set tested to ISO 8528-5 for transient response
- 100% load factor
- Verified product design, quality and performance integrity
- All engine systems are prototype and factory tested

Complete range of accessories available

- Control panel
- Power panel
- Circuit breaker/power distribution
- Fuel system
- Fuel connections with shut-off valve mounted to base frame
- Starting/charging system
- Exhaust system
- Mechanical and electrical driven radiators
- Medium and oversized voltage alternators

Emissions

- NOx emission optimized

Certifications

- CE certification option
- Unit certificate acc. to VDE-AR-N 4110

* Changes to the standard parameter sets (alternator-regulator and genset-controller) are necessary



A Rolls-Royce
solution

Application data ¹⁾

Engine

Manufacturer	mtu
Model	16V4000G14F
Type	4-cycle
Arrangement	16V
Displacement: l	76.3
Bore: mm	170
Stroke: mm	210
Compression ratio	16.4
Rated speed: rpm	1500
Engine governor	ECU 9
Max power: kWm	1798
Air cleaner	dry

Fuel system

Maximum fuel lift: m	5
Total fuel flow: l/min	20

Fuel consumption ²⁾

	l/hr	g/kwh
At 100% of power rating:	472.2	218
At 75% of power rating:	346.1	213
At 50% of power rating:	234	216

Liquid capacity (lubrication)

Total oil system capacity: l	260
Engine jacket water capacity: l	175
Intercooler coolant capacity: l	50

Combustion air requirements

Combustion air volume: m ³ /s	3.2
Max. air intake restriction: mbar	50

Cooling/radiator system

Coolant flow rate (HT circuit): m ³ /hr	68.5
Coolant flow rate (LT circuit): m ³ /hr	30
Heat rejection to coolant: kW	790
Heat radiated to charge air cooling: kW	460
Heat radiated to ambient: kW	90
Fan power for electr. radiator (40°C): kW	70

Exhaust system

Exhaust gas temp. (after turbocharger): °C	480
Exhaust gas volume: m ³ /s	7.4
Maximum allowable back pressure: mbar	85
Minimum allowable back pressure: mbar	30

Standard and optional features

System ratings (kW/kVA)

Generator model	Voltage	NOx emission optimized					
		without radiator			with mechanical radiator		
		kWel	kVA*	AMPS	kWel	kVA*	AMPS
Leroy Somer LSA52.3 S7 (Low voltage Leroy Somer standard)	380 V	1728	2160	3282	1656	2070	3145
	400 V	1728	2160	3118	1656	2070	2988
	415 V	1728	2160	3005	1656	2070	2880
Marathon 744RSL7092 (Low voltage Marathon)	380 V	1704	2130	3236	1640	2050	3115
	400 V	1704	2130	3074	1640	2050	2959
	415 V	1696	2130	2949	1640	2050	2852
Marathon 1020FDL7093 (Low voltage Marathon oversized)	380 V	1704	2130	3236	1640	2050	3115
	400 V	1704	2130	3074	1640	2050	2959
	415 V	1696	2130	2949	1640	2050	2852
Marathon 1020FDH7097 (Medium volt. marathon)	11 kV	1712	2140	112	1640	2050	108
Leroy Somer LSA53.2 XL9 (Med. volt. Leroy Somer)	11 kV	1728	2160	113	1656	2070	109

* cos phi = 0.8

1 All data refers only to the engine and is based on ISO standard conditions (25°C and 100m above sea level).

2 Values referenced are in accordance with ISO 3046-1. Conversion calculated with fuel density of 0.83 g/ml. All fuel consumption values refer to rated engine power.

Standard and optional features

Engine

- 4-cycle
- Standard single stage air filter
- Oil drain extension & shut-off valve
- Closed crankcase ventilation improved oil separator
- Governor-electronic isochronous
- Common rail fuel injection
- NOx emission optimized engine
- Centrifugal oil filter

Generator

- 4 pole three-phase synchronous generator
- Brushless, self-excited, self-regulating, self-ventilated
- Digital voltage regulator
- Anti condensation heater
- Stator winding Y-connected, accessible neutral (brought out)
- Protection IP23
- Insulation class H, utilization acc. to H
- Radio suppression EN 55011, group 1, cl. B
- Short circuit capability 3xIn for 10sec
- Winding and bearing RTDs (without monitoring)
- Excitation by AREP
- Mounting of CT's: 2 core CT's
- Winding pitch: 2/3 winding
- Voltage setpoint adjustment ± 10%
- Meets NEMA MG-1, BS 5000, IEC 60034-1, VDE 0530, DIN EN 12601, AS 1359 and ISO 8528-3 requirements
- Leroy Somer low voltage generator
- Marathon low voltage generator
- Oversized generator
- Medium voltage generator

Cooling system

- Jacket water pump
- Thermostat(s)
- Water charge air cooling
- Mechanical radiator
- Electrical driven front-end cooler
- Jacket water heater

Control panel

- Unit cabling with coded plugs for easy connection of customer-specific controls (V0)
- Pre-wired control cabinet for easy application of customized controller (V1+)
- Island operation (V2)
- Automatic mains failure operation with ATS (V3a)
- Automatic mains failure operation incl. control of generator and mains breaker (V3b)
- Island parallel operation of multiple gensets (V4)
- Automatic mains failure operation with short (< 10s) mains parallel overlap synchronization (V5)
- Mains parallel operation of a single genset (V6)
- Mains parallel operation of multiple gensets (V7)
- Basler controller
- Deif controller
- Complete system metering
- Digital metering
- Engine parameters
- Generator protection functions
- Engine protection
- SAE J1939 engine ECU communications
- Parametrization software
- Multilingual capability
- Multiple programmable contact inputs
- Multiple contact outputs
- Event recording
- IP 54 front panel rating with integrated gasket
- Different expansion modules
- Remote annunciator
- Daytank control
- Generator winding temperature monitoring
- Generator bearing temperature monitoring
- Modbus TCP-IP

Connectivity

The engine system automatically collects and transfers engine data to the manufacturer from time to time. The data is used by the manufacturer for the purposes of product

development and improvement as well as service optimization. Users can log in or register via <https://mtu-go.com> and also gain insight into the data.

- Represents standard features
- Represents optional features

Standard and optional features

Power panel

- Supply electrical driven radiator from 45kW – 75kW

Circuit breaker/power distribution

- 3-pole circuit breaker
- 4-pole circuit breaker
- Electrical-actuated circuit breaker
- Base frame mounted GCB, pre-wired with generator, ready for commissioning

Fuel system

- Flexible fuel connectors mounted to base frame
- Fuel filter with water separator
- Fuel filter with water separator heavy-duty
- Switchable fuel filter with water separator
- Switchable fuel filter with water separator heavy-duty
- Seperate fuel cooler
- Fuel cooler integrated into cooling equipment

Starting/charging system

- 24V starter
- Redundant starting system
- Starter batteries, cables, rack, disconnect switch (lockable)
- Battery charger
- Alternator

Mounting system

- Welded base frame
- Resilient engine and generator mounting
- Modular base frame design
- Base frame mounting on foundation/base plate with using clamping brackets

Exhaust system

- Exhaust bellows with connection flange
- Exhaust silencer with 10 dB(A) sound attenuation
- Exhaust silencer with 30 dB(A) sound attenuation
- Exhaust silencer with 40 dB(A) sound attenuation
- Y-connection-pipe

Represents standard features

Represents optional features

Weights and dimensions

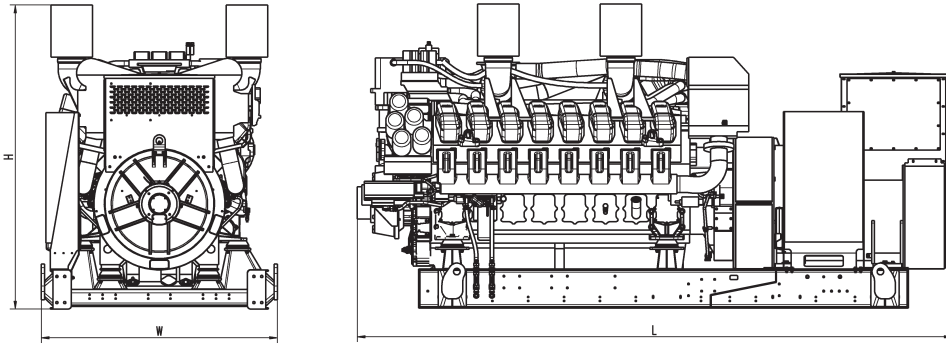

Drawing above for illustration purposes only, based on a standard open power 400 Volt engine-generator set. Lengths may vary with other voltages. Do not use for installation design. See website for unit specific template drawings.

System	Dimensions (LxWxH)	Weight (dry/less tank)
Open power unit (OPU)	4766 x 1810 x 2330 mm	12428 kg

Weights and dimensions are based on open power units and are estimates only. Consult the factory for accurate weights and dimensions for your specific engine-generator set.

Sound data

– Consult your local **mtu** distributor for sound data.

Emissions data

– Consult your local **mtu** distributor for emissions data.

Rating definitions and conditions

- Grid stability power ratings apply to installations serving electric utility programs. At constant or varying load, the number of generator set operating hours is limited to 1000 hours per year with no more than 500 hours per year at 100% load without interruption. A 10% overload capacity is available for one hour in twelve. Ratings are in accordance with ISO 8528-1, ISO 3046-1, BS 5514 and AS 2789. Average load factor: $\leq 100\%$.
- Consult your local **mtu** distributor for derating information.